

**CITY OF EVANSTON**  
**SPECIFICATIONS AND BID DOCUMENTS**  
**Construction Bid with Sub-Contractors**

**BID NUMBER: 26-29**

**For**

**Levy Center Kitchen Remodel**  
**April 16, 2026**



**BID DUE DATE:** 2:00 P.M., Tuesday, May 12, 2026

**VIRTUAL BID OPENING:** 2:15 P.M., Tuesday, May 12, 2026  
**Google Meet ID:**  
[meet.google.com/erk-vjyw-pza](https://meet.google.com/erk-vjyw-pza)  
**Phone Numbers:**  
(US) [+1 617-675-4444](tel:+16176754444)  
PIN: 491 020 418 0044#

**NON-MANDATORY PRE-BID MEETING** 9:00 A.M. Thursday, April 23, 2026,  
300 Dodge Ave, Evanston, IL 60202

**BID BOND:** 5% of Contract Amount

**PERFORMANCE/MATERIAL & LABOR PAYMENT BOND:** 100% of Contract Amount

**CONTRACT PERIOD:** Contract Award through Deadlines Below  
Substantial Completion Deadline: October 5, 2026  
Final Completion Deadline: November 6, 2026

**ELECTRONIC BID SUBMITTAL:**

Bid responses will only be accepted electronically  
via E-bidding through DemandStar ([WWW.DEMANDSTAR.COM](http://WWW.DEMANDSTAR.COM))

**It is highly recommended that new DemandStar users complete the account setup process prior to the project due date/time.**

## TABLE OF CONTENTS

| SPECIFICATION SECTION<br>NUMBERS                                                        | PAGES             |
|-----------------------------------------------------------------------------------------|-------------------|
| <b>DIVISION 0 – BIDDING REQUIREMENTS</b>                                                |                   |
| Notice to Bidders                                                                       | 1                 |
| Instructions to Bidders/Requirements for Bidding                                        | 12                |
| General Condition                                                                       | 12                |
| Insurance Requirements                                                                  | 1                 |
| <b>RETURN ALL EXHIBITS WITH THE BID</b>                                                 |                   |
| Exhibit A Bid Form                                                                      | 8                 |
| <b>*Exhibit B RBO Bid Notice and Compliance Certification</b>                           | <b>3</b>          |
| <b>*Exhibit C Local Employment Program Compliance</b>                                   | <b>2</b>          |
| <b>*Exhibit D City of Evanston M/W/D/EBE Policy</b>                                     | <b>1</b>          |
| Exhibit E M/W/D/EBE Participation Compliance Form                                       | 2                 |
| Exhibit F M/W/D/EBE Participation Waiver Request                                        | 1                 |
| Exhibit G Construction Contractors' Assistance Organizations                            | 1                 |
| Exhibit H Certification of Bidder Regarding Equal<br>Employment Opportunity             | 1                 |
| Exhibit I Disclosure of Ownership Interests                                             | 2                 |
| Exhibit J Additional Information Sheet                                                  | 1                 |
| Exhibit K Certification of Compliance with Prevailing Wage<br>Rate Act                  | 1                 |
| Exhibit L Major Sub-Contractors Listing                                                 | 1                 |
| Exhibit M Conflict of Interest                                                          | 1                 |
| Exhibit N Signature Form                                                                | 1                 |
| Exhibit O Contractor Services Agreement Acknowledgment<br>Contractor Services Agreement | 23                |
| Exhibit P BID Bond Submittal Label                                                      | 1                 |
| <b>DIVISION 1 – General Requirements</b>                                                |                   |
| 01000 Project Requirements                                                              | 01000-1 – 01000-2 |
| 01010 Summary of Work                                                                   | 01010-1 – 01010-2 |
| 01027 Applications for Payment                                                          | 01027-1 – 01027-2 |
| 01028 Change Order Procedure                                                            | 01028-1 – 01028-3 |
| 01060 Regulatory Requirements                                                           | 01060-1 – 01060-2 |
| 01200 Project Meetings                                                                  | 01200-1 – 01200-3 |
| 01210 Allowances                                                                        | 01210-1 – 01210-2 |
| 01290 Payment Procedures                                                                | 01290-1 – 01290-3 |
| 01300 Submittals                                                                        | 01300-1 – 01300-7 |
| 01400 Quality Control                                                                   | 01400-1 – 01400-3 |
| 01600 Materials and Equipment                                                           | 01600-1 – 01600-3 |
| 01630 Substitutions                                                                     | 01630-1 – 01630-2 |
| 01700 Project Closeout                                                                  | 01700-1 – 01700-2 |
| 01710 Cleaning                                                                          | 01710-1 – 01710-2 |

|       |                                |                   |
|-------|--------------------------------|-------------------|
| 01730 | Operating and Maintenance Data | 01730-1 – 01730-3 |
| 01740 | Warrantees and Bonds           | 01740-1 – 01740-2 |

**DIVISION 2 – DIVISION 33**

|       |                      |                   |
|-------|----------------------|-------------------|
| 02411 | Selective Demolition | 02411-1 – 02411-6 |
|-------|----------------------|-------------------|

**ATTACHMENTS**

|                                                                                            |    |
|--------------------------------------------------------------------------------------------|----|
| Drawings                                                                                   | 5  |
| G COVER PAGE & GENERAL NOTES                                                               |    |
| A DEMOLITION & NEW WORK PLANS, ELEVATIONS                                                  |    |
| E ELECTRICAL PLAN & PANEL SCHEDULE                                                         |    |
| M MECHANICAL PLAN & SCHEDULES, ELECTRICAL POWER PLAN,<br>REFLECTED CEILING PLAN, ROOF PLAN |    |
| P PLUMBING PLANS & RISER DIAGRAMS                                                          |    |
| Equipment List                                                                             | 8  |
| Ordinance 1-O-26, Responsible Bidder Ordinance                                             | 21 |
| Prevailing Wages                                                                           | 10 |
| DemandStar E-bidding Information                                                           | 2  |

**\*NOTE: THE SELECTED BIDDER WILL BE SUBJECT TO THE REGULATIONS CONTAINED IN CITY OF EVANSTON ORDINANCE 60-O-14 AMENDMENTS TO THE LOCAL EMPLOYMENT PROGRAM (LEP) AND ORDINANCE 1-O-26 THE RESPONSIBLE BIDDER ORDINANCE**

## CITY OF EVANSTON

### NOTICE TO BIDDERS

The City's Purchasing Office will receive bids until 2:00 P.M. local time Tuesday, May 12, 2026, and will be publicly read virtually via Google Meets at 2:15 P.M. Interested parties can use the following link: [meet.google.com/erk-vjyw-pza](https://meet.google.com/erk-vjyw-pza) or join by phone 617-675-4444 PIN: 491 020 418 0044# to access the virtual bid opening. Responses will only be accepted electronically via E-bidding through DemandStar ([www.demandstar.com](http://www.demandstar.com)). Although registration is required, vendors can download solicitations and upload responses for free. Bids shall cover the following:

#### **Levy Center Kitchen Remodel** **Bid Number: 26-29**

Work on this project includes improvements to the Levy Center Kitchen, located at 200 Dodge Ave, Evanston, Illinois.

A non-mandatory pre-bid meeting will be held at the project site: 300 Dodge Ave, Evanston, IL 60202 at 9:00 A.M. on Thursday, April 23, 2026. The above item shall conform to the Invitation for Bids on file in the Purchasing Office. Parties interested in submitting a bid should contact the Purchasing Office to receive a copy of the bid or see the City's website at: [www.cityofevanston.org/business/bids\\_proposals.php](http://www.cityofevanston.org/business/bids_proposals.php) or DemandStar at: [www.demandstar.com](http://www.demandstar.com).

The City of Evanston (the City) in accordance with the laws of the State of Illinois, hereby notifies all Bidders that it will affirmatively ensure that the contract(s) entered into pursuant to this Notice will be awarded to the successful Bidders without discrimination on the ground of race, color, religion, sex, age, sexual orientation, marital status, disability, familial status or national origin. The State of Illinois requires, under Public Works contracts, that the general prevailing rate of wages in this locality be paid for each craft or type of worker hereunder. This requirement is in accordance with the Prevailing Wage Act (820 ILCS 130) as amended. The City of Evanston reserves the right to reject any or all submittals or to accept the submittal(s) deemed most advantageous to the City.

The Evanston City Council also reserves the right to award the contract to an Evanston firm if that firm's bid is within 5% of the low bid.

Each Bidder shall be required to submit with their bid a disclosure of ownership interest statement form in accordance with the provisions of City Code Section 1-18-1 *et seq.* Failure to submit such information will result in the disqualification of such bid.

Tammi Nunez  
Purchasing Manager

## INSTRUCTIONS TO BIDDERS/REQUIREMENTS FOR BIDDING (CONTRACTS OVER \$25,000)

### 1. **ONLINE NOTIFICATION OF SOLICITATIONS**

---

The City is utilizing Demandstar.com ([www.demandstar.com](http://www.demandstar.com)) for online notification purposes only for sealed bids when it is anticipated that the amount of the resulting contract will be in excess of its formal bid limit of \$25,000, such as this requirement. Interested Bidders are required to submit a sealed bid to the City by the date/time indicated for this requirement on the forms provided by the City.

### 2. **SUBMISSION OF BIDS**

---

- A. The City of Evanston will no longer accept hard copy paper submittals for any solicitation. Responses will only be accepted electronically via E-bidding through DemandStar ([WWW.DEMANDSTAR.COM](http://WWW.DEMANDSTAR.COM)). Although registration is required, vendors can download solicitations and upload bid responses for free. **Please refer to the attached DemandStar E-bidding documents.**
- B. ANY BIDS RECEIVED AFTER THE TIME AND DATE SPECIFIED FOR THE RECEIPT OF BIDS WILL NOT BE ACCEPTED. It is the sole responsibility of the Bidder to ensure that his or her bid is delivered by the stated bid opening time. THE CITY IS NOT RESPONSIBLE FOR INCOMPLETE UPLOADED SUBMITTALS.
- C. Bids will be opened on the date and time stated.
- D. Any Bidder may withdraw his or her bid by letter or with proper identification by personally securing his or her bid at any time prior to the stated bid opening time. No telephone request for withdrawal of bids will be honored.

### 3. **PREPARATION OF BIDS**

---

The Bidder must prepare the bid on the attached bid forms. Unless otherwise stated, all blank spaces on the bid form or pages must be filled in. Either a unit price, lump sum price, or a "no-bid", as the case may be, must be stated for each and every item and must be either typed in or written in ink.

### 4. **SIGNING OF BIDS**

---

- A. Bids which are signed for a partnership should be signed in the firm's name by all partners or in the firm's name by an Attorney-in-Fact. If signed by an Attorney-in-Fact, there should be attached to the bid a Power of Attorney evidencing authority to sign the bid, dated the same date as the bid, and executed by all partners of the firm.
- B. Bids which are signed for a corporation should have the correct corporate name thereon and signature of an authorized officer of the corporation manually written below the corporate name following words "By: \_\_\_\_\_" title of office held by the

person signing for corporation, which shall appear below signature of an officer.

- C. Bids which are signed by an individual doing business under a fictitious name should be signed in the name of the individual "doing business as. \_\_\_\_\_."
- D. The name of each person signing the bid shall be typed or printed below his or her signature.

**5. CONSIDERATION OF BIDS**

---

The Purchasing Specialist shall represent and act for the City in all matters pertaining to this bid and the contract in conjunction therewith.

**6. WITHDRAWAL OF BIDS**

---

Bidders may withdraw or cancel their bids at any time prior to the advertised bid opening time. After the bid opening time, no bid shall be withdrawn or canceled for a period of sixty (60) calendar days. When contract approval is required by another agency, such as the Federal Government or the State of Illinois, no bid shall be withdrawn or canceled for a period of ninety (90) calendar days.

**7. ERRORS IN BIDS**

---

Bidders are cautioned to verify their bids before submission. Negligence on the part of the respondent in preparing the bid confers no right for withdrawal or modification of the bid after it has been opened. In case of error in the extension of prices in the bid, unit prices will govern.

**8. ADDENDA**

---

- A. Any and all changes to the specifications/plans are valid only if they are included by written addendum to all Bidders. Each Bidder must acknowledge receipt of any addenda by indicating on the Bid form. Each Bidder, by acknowledging receipt of any addenda, is responsible for the contents of the addenda and any changes to the bid therein. Failure to acknowledge any addenda may cause the bid to be rejected.
- B. Addenda information is available over the internet at: [City of Evanston Notices to Bidders](#) or [www.demandstar.com](http://www.demandstar.com), or by contacting the Purchasing Office.

**9. RESERVED RIGHTS**

---

The City of Evanston reserves the right at any time and for any reason to cancel his or her solicitation, to accept or reject any or all bids or any portion thereof, or to accept an alternate response. The City reserves the right to waive any immaterial defect in any response. The City may seek clarification from any respondent at any time, and failure to respond within a reasonable time period, or as otherwise directed, will be cause for rejection.

**10. AWARD**

---

It is the intent of the City to award a contract to the lowest responsible Bidder

meeting specifications. The City reserves the right to determine the lowest responsible Bidder on the basis of an individual item, groups of items, or in any way determined to be in the best interest of the City. Award will be based on the following factors (where applicable): (a) adherence to all conditions and requirements of the bid specifications; (b) price; (c) qualifications of the Bidder, including past performance, financial responsibility, general reputation, experience, service capabilities, and facilities; (d) delivery or completion date; (e) product appearance, workmanship, finish, taste, feel, overall quality, and results of product testing; (f) maintenance costs and warranty provisions; and (g) repurchase or residual value.

#### **11. INTERPRETATION OR CORRECTION OF BIDDING DOCUMENTS**

---

Bidder's shall promptly notify the City of any ambiguity, inconsistency, or error that they discover upon examination of the bidding documents. Interpretations, corrections, and changes will be made by addendum. Each Bidder shall ascertain prior to submitting a bid that all addenda have been received and are acknowledged in the bid.

#### **12. INCONSISTENCIES AND OMISSIONS**

---

These specifications and the accompanying plans, if any, are intended to include all information necessary for the work contemplated. If, by inadvertence or otherwise, the plans or specifications omit some information necessary for that purpose, the contractor shall, nevertheless, be required to perform such work at no additional cost to the City so that the project may be completed according to the true intent and purpose of the plans and specifications.

#### **13. CONDITIONS**

---

Bidders are advised to become familiar with all conditions, instructions, and specifications governing his or her bid. Once the award has been made, failure to have read all the conditions, instructions and specifications of this contract shall not permit the Bidder to amend contract or to request additional compensation.

#### **14. VERIFICATIONS OF DATA**

---

- A. It is understood and agreed that the unit quantities given in these specifications are approximate only, and the contractor shall verify these quantities before bidding as no claim shall be made against the City on, or account of, any excess or deficiency in the same.
- B. The contractor shall have visited the premises and determined for itself, by actual observation, boring, test holes, or other means, the nature of all soil and water conditions (both above and below ground in the line of work) that may be encountered in all construction work under this contract. The cost of all such inspection, borings, etc. shall be borne by the contractor, and no allowance will be made for the failure of the contractor to estimate correctly the difficulties attending the execution of the work.

## **15. SPECIFICATIONS**

---

Reference to brand names and numbers is meant to be descriptive, not restrictive, unless otherwise specified. Bids on equivalent items will be considered, provided the Bidder clearly states exactly what is proposed to be furnished, including complete specifications. Unless the Bidder specifies otherwise, it is understood the Bidder is offering a referenced brand item as specified or is bidding as specified when no brand is referenced, and does not propose to furnish an "equal." The City reserves the right to determine whether a substitute offer is equivalent to, and meets the standard of quality indicated by the brand name and number.

## **16. SAMPLES**

---

When samples of items are called for by the specifications, samples must be furnished free of expense, and if not destroyed in the evaluation process will be returned at the Bidder's expense upon request. Request for the return of samples must accompany the sample and must include a UPS/Fed-Ex Pickup Slip, postage, or other acceptable mode of return. Individual samples must be labeled with Bidder's name, invitation number, item reference, manufacturer's brand name and number.

## **17. REGULATORY COMPLIANCE**

---

Each Bidder represents and warrants that the goods or services furnished hereunder (including all labels, packages and containers for said goods) comply with all applicable standards, rules and regulations in effect under the requirements of all Federal, State, and local laws, rules and regulations as applicable, including the Occupational Safety and Health Act as amended, with respect to design, construction, manufacture, or use for their intended purpose of said goods or services. Each Bidder must furnish a "Material Safety Data Sheet" in compliance with the Illinois Toxic Substances Disclosure to Employees Act when required.

## **18. PRICING**

---

The price quoted for each item is the full purchase price, including delivery to destination, and includes all transportation and handling charges, materials or service costs, patent royalties, and all other overhead charges of every kind and nature. Unless otherwise specified, prices shall remain firm for the contract period.

## **19. DISCOUNTS**

---

Prices quoted must be net after deducting all trade and quantity discounts. Where cash discounts for prompt payment are offered, the discount period shall begin with the date of receipt of a correct invoice or receipt or final acceptance of goods, whichever is later.

## **20. INSPECTION**

---

Materials or equipment purchased are subject to inspection and approval at the City's destination. The City reserves the right to reject and refuse acceptance of items which are not in accordance with the instructions, specifications, drawings or data of Seller's warranty (express or implied). Rejected materials or equipment

shall be removed by, or at the expense of, the Seller promptly after rejection.

**21. BIDS AND PLAN DEPOSITS**

---

- A. When required on the cover sheet, all bids shall be accompanied by a bid deposit in the amount specified. Bid deposits shall be in the form of cash, a certified check, or cashier's check drawn on a responsible bank doing business in the United States and shall be made payable to the City of Evanston. Bid Bonds are also acceptable. All bids not accompanied by a bid deposit, when required, will be rejected.
- B. The City will return the bid deposits of all but the 3 lowest qualified Bidders, whose deposit will be held until contract award or at the expiration of the sixty-day or ninety-day period for bid award.
- C. The bid deposit of the successful Bidder will be retained until contract documents have been executed and the Contractor has submitted all the required information. Failure to comply with the terms of this specification may be cause for forfeiture of said deposit.
- D. When required, plan deposits will be refunded should the plans be returned in good condition within 10 days of the bid opening.

**22. DISPUTES**

---

Any dispute concerning a question of fact arising under this bid shall be decided by the Purchasing Specialist, who shall issue a written decision to the Bidder. The decision of the Purchasing Specialist shall be final and binding.

**23. CATALOGS**

---

Each Bidder shall submit, when requested by the Purchasing Specialist, catalogs, descriptive literature, and detailed drawings, fully detailing features, designs, construction, appointments, finishes and the like not covered in the specifications, necessary to fully describe the material or work proposed to be furnished.

**24. TAXES**

---

- A. Federal Excise Tax does not apply to materials purchased by the City of Evanston by virtue of Exemption Certificate No. A-208762, Illinois Retailers' Occupation Tax, Use Tax, and Municipal Retailers' Occupation Tax do not apply to materials or services purchased by the City of Evanston by virtue of Statute.
- B. The City of Evanston is exempt from Illinois Sales Tax by virtue of Exemption Identification number E9998-1750.
- C. The City's federal tax ID number is 36-6005870.

**25. PERMITS & FEES**

---

All Bidders awarded a contract must secure and pay for any licenses required by the City of Evanston. Necessary building permits will be required, but all permit fees will be waived and moneys for same must not be included in any bid.

## 26. ROYALTIES & PATENTS

---

Seller must pay all royalties and license fees. Seller must defend all suits or claims for infringement of any patent, copyright or trademark rights, and must hold the City harmless from loss on account thereof.

## 27. LOCAL PREFERENCE POLICY

---

The Evanston City Council reserves the right to award the contract to an Evanston firm if the firm's bid is within five (5%) percent of the low bid of a non-Evanston firm.

## 28. RESPONSIBLE BIDDER POLICY

---

All contractors must follow the requirements of Ordinance 1-O-26, the City's Responsible Bidder Ordinance. Ordinance 1-O-26 is attached hereto for reference. The following items are required of all contractors:

- **Local Employment Program (LEP):** Contractors must ensure that at least 15% of total on-site work hours are performed by Evanston residents and that at least one Evanston resident is hired. These obligations apply across all tiers of subcontractors and must be documented.
- **Apprenticeship Training Program:** Bidders shall submit evidence of enrollment in a U.S. Department of Labor registered Apprenticeship Training Program for each construction craft performed. These programs must have graduated at least five apprentices in each of the last five years.
- **Minimum Performance Threshold:** Named bidder must directly perform at least 25% of project services. Affiliates or subsidiaries do not count toward this percentage.
- **Commercially Useful Function:** All contractors and subcontractors must actively manage and perform contract work. Excessive subcontracting or pass-through participation may result in disqualification.
- **Subcontractor Disclosure:** Submit the name, address, and documentation for all subcontractors with bid. Each subcontractor must comply with all requirements set forth in this template.

## 29. POWER OF ATTORNEY

---

An Attorney-In-Fact, who signs any and all of the bond or contract bonds submitted with this bid, must file with each bond a certified and effectively dated copy of their Power of Attorney. These dates should be the same or after the date of the contract.

## 30. WARRANTY

---

- A. The contractor warrants that all goods and services furnished to the City shall be in accordance with specifications and free from any defects of workmanship and materials: that goods furnished to the City shall be merchantable and fit for the City's described purposes, and that no governmental law, regulation, order, or rule

has been violated in the manufacture or sale of such goods.

- B. The contractor warrants all equipment furnished to be in acceptable condition, and to operate satisfactorily for a period of one (1) year from delivery of, or the completion of installation, whichever is latest, unless stated otherwise in the specifications, and that if a defect in workmanship and/or quality of materials are evidenced in this period, the Seller shall remit full credit, replace, or repair at City's discretion immediately, such equipment and/or parts that are defective at no additional cost to the City.
- C. The contractor warrants to the City that each item furnished hereunder, and any component part thereof, will be new and in conformity with the specifications in all respects, unless otherwise specified, and is of the best quality of its respective kind, free from faulty workmanship, materials, or design, and installed sufficiently to fulfill any operating conditions specified by the City.
- D. The contractor shall repair or replace any item or component part thereof found not to be in conformity with this paragraph, provided the City notifies the Seller of such nonconformity within one (1) year after initial use or within eighteen (18) months after delivery, whichever occurs first. In the event Seller fails to proceed diligently to so replace or repair within a reasonable time after receipt of such notice, the City may undertake or complete such replacement or repair for Seller's account, and the seller will be responsible for any additional costs. Acceptance shall not relieve the seller of its responsibility.

### **31. INCURRED COSTS**

---

The City will not be liable for any costs incurred by Bidders in replying to this invitation for bids.

### **32. VARIANCES**

---

Each Bidder must state or list by reference any variations to specifications, terms, and/or conditions set forth herein with its bid.

### **33. INDEMNIFICATION**

---

- A. The awarded Bidder/Contractor shall defend, indemnify and hold harmless the City and its officers, elected and appointed officials, agents, and employees from any and all liability, losses, or damages as a result of claims, demands, suits, actions, or proceedings of any kind or nature, including but not limited to costs, and fees, including attorney's fees, judgments or settlements, resulting from or arising out of any negligent or willful act or omission on the part of the Contractor or Contractor's sub-contractors, employees, agents or sub-contractors during the performance of this Agreement. Such indemnification shall not be limited by reason of the enumeration of any insurance coverage herein provided. This provision shall survive completion, expiration, or termination of this Agreement.
- B. Nothing contained herein shall be construed as prohibiting the City, or its officers,

agents, or employees, from defending through the selection and use of their own agents, attorneys, and experts, any claims, actions or suits brought against them. The Contractor shall be liable for the reasonable costs, fees, and expenses incurred in the defense of any such claims, actions, or suits. Nothing herein shall be construed as a limitation or waiver of defenses available to the City and employees and agents, including but not limited to the Illinois Local Governmental and Governmental Employees Tort Immunity Act, 745 ILCS 10/1-101 *et seq.*

- C. At the City Corporation Counsel's option, Contractor must defend all suits brought upon all such Losses and must pay all costs and expenses incidental to them, but the City has the right, at its option, to participate, at its own cost, in the defense of any suit, without relieving Contractor of any of its obligations under this Agreement. Any settlement of any claim or suit related to this Project by Contractor must be made only with the prior written consent of the City Corporation Counsel, if the settlement requires any action on the part of the City.
- D. To the extent permissible by law, Contractor waives any limits to the amount of its obligations to indemnify, defend, or contribute to any sums due under any Losses, including any claim by any employee of Contractor that may be subject to the Illinois Compensation Act, 820 ILCS 305/1 *et seq.* or any other related law or judicial decision, including but not limited to, *Kotecki v. Cyclops Welding Corporation*, 146 Ill. 2d 155 (1991). The City, however, does not waive any limitations it may have on its liability under the Illinois Workers Compensation Act, the Illinois Pension Code or any other statute.
- E. The Contractor shall be responsible for any losses and costs to repair or remedy work performed under this Agreement resulting from or arising out of any act or omission, neglect, or misconduct in the performance of its Work or its sub-contractors' work. Acceptance of the work by the City will not relieve the Contractor of the responsibility for subsequent correction of any such error, omissions, and/or negligent acts or of its liability for loss or damage resulting therefrom.
- F. All provisions of this Section 32 shall survive completion, expiration, or termination of this Agreement.

#### **34. DEFAULT**

---

Time is of the essence as to the awarded contract and, of delivery or acceptable items or rendering of services is not completed by the time promised, the City reserves the right, without liability, in addition to its other rights and remedies, to terminate the contract by notice effective when received by Seller, as to stated items not yet shipped or services not yet rendered and to purchase substitute items or services elsewhere and charge the Seller with all losses incurred. The City shall be entitled to recover its attorney's fees and expenses in any successful action by the City to enforce this contract.

**35. GOVERNING LAW**

---

This contract shall be governed by and construed according to the laws of the State of Illinois. In the event of litigation, the venue will be Cook County, Illinois.

**36. EQUAL EMPLOYMENT OPPORTUNITY**

---

- A. In the event of the contractor's noncompliance with any provision of the Illinois Human Rights Act or Section 1-12-5 of the Evanston City Code, the contractor may be declared non-responsible and therefore ineligible for future contracts or sub-contracts with the City of Evanston, and the contract may be canceled or voided in whole or in part, and such other sanctions or penalties may be imposed or remedies invoked as provided by Statute or regulation.
- B. During the performance of this contract, the contractor agrees as follows:
1. That it will not discriminate against any employee or applicant for employment because of race, color, religion, sex, national origin or ancestry, or age, or physical or mental handicap that does not impair the ability to work, and further that it will examine all job classifications to determine if minority persons or women are underutilized and will take appropriate affirmative action to rectify any such underutilization. Contractor shall comply with all requirements of City of Evanston Code Section 1-12-5.
  2. That, in all solicitations or advertisements for employees placed by it or on its behalf, it will state that all applicants will be afforded equal opportunity without discrimination because of race, color, religion, sex, national origin or ancestry.
  3. That, if it hires additional employees in order to perform this contract, or any portion hereof, it will determine that availability (in accordance with the Fair Employment Commission's Rules and Regulations for Public Contracts) of minorities and women in the area(s) from which it may reasonably recruit and it will hire for each job classification for which employees are hired in such a way that minorities and women are not underutilized.
  4. That it will send to each labor organization or representative of workers with which it has or is bound by a collective bargaining or other agreement or understanding, a notice advising such labor organization or representative of the contractor's obligations under the Illinois Fair Employment Practices Act and the Fair Employment Practices Commission's Rules and Regulations for Public Contracts. If any such labor organization or representative fails or refuses to cooperate with the contractor in its efforts to comply with such Act and Rules and Regulations, the contractor will promptly so notify the Illinois Fair Employment Practices Commission and the contracting agency and will recruit employees from other sources when necessary to fulfill its obligations hereunder.

5. That it will submit reports as required by the Illinois Fair Employment Practices Commission's Rules and Regulations for Public Contracts, furnish all relevant information as may from time to time be requested by the Fair Employment Practices Commission or the contracting agency, and in all respects comply with the Illinois Fair Employment Practices Commission's Rules and regulations for Public Contracts.
6. That it will permit access to all relevant books, records, accounts and work sites by personnel of the contracting agency, the City Manager, the Commission and the Illinois Fair Employment Practices Commission for purposes of investigation to ascertain compliance with the Illinois Fair Employment Practices Act and the Fair Employment Practices Act and the Fair Employment Practices Commission's Rules and Regulations for Public Contract.
7. That it will include verbatim or by reference the provisions of subsections (A) through (G) of this clause in every performance sub-contract as defined in Section 2.10(b) of the Fair Employment Practices Commission's Rules and Regulations for Public Contracts so that such provisions will be binding upon every such sub-contractor; and that it will also include the provisions of subsections (A), (E), (F), and (G) in every supply sub-contract as defined in Section 2.10(a) of the Fair Employment Practices Commission's Rules and Regulations for Public Contracts so that such provisions will be binding upon every such sub-contractor. In the same manner as with other provisions of this contract, the contractor will be liable for compliance with applicable provisions of this clause by all its sub-contractors; and further it will promptly notify the contracting agency and the Illinois Fair Employment Practices Commission in the event any sub-contractor fails or refuses to comply therewith. In addition, no contractor will utilize any sub-contractor declared by the Fair Employment Practices Commission to be non-responsible and therefore ineligible for contracts or sub-contracts with the State of Illinois or any of its political subdivisions or municipal corporations.

**37. M/W/D/EBE GOAL**

---

The City of Evanston has a goal of awarding 25% of its contracts to Minority-Owned, Women-Owned, Disadvantaged Enterprise, and Evanston-based businesses (M/W/D/EBEs). All Bidders must state the proposed involvement of M/W/D/EBEs in completing a portion of the services required by the City by completing the attached M/W/D/EBE forms. Any questions regarding M/W/D/EBE compliance should be submitted in writing to Tammi Nunez, Purchasing Manager at [tnunez@cityofevanston.org](mailto:tnunez@cityofevanston.org).

**38. LOCAL EMPLOYMENT PROGRAM REQUIREMENTS**

---

In an effort to increase hiring of economically disadvantaged Evanston residents on certain City construction projects, the contractor shall comply with the provisions of the City of Evanston's Local Employment Program Ordinance (LEP) set forth in Section 1-17-1 (C) of the Evanston City Code. The intent of the LEP is

to have Evanston residents employed at the construction site as laborers, apprentices and journeymen in such trades as electrical, HVAC, carpenters, masonry, concrete finishers, truck drivers and other construction occupations necessary for the project. Any questions regarding LEP compliance should be submitted in writing to Jessica Cooper, the Workforce Development Coordinator at [jcooper@cityofevanston.org](mailto:jcooper@cityofevanston.org) or Tammi Nunez Purchasing Manager at [tnunez@cityofevanston.org](mailto:tnunez@cityofevanston.org).

**NOTE: CITY OF EVANSTON ORDINANCE 60-O-14 AMENDMENT LOCAL EMPLOYMENT PROGRAM (LEP) available on the city website at: Ordinance 60-O-14 Amendment LEP**

**39. BIDDER SUBMITAL REQUIREMENTS FOR RESPONSIBLE BIDDER ORDINANCE**

| <b>Documentation or Certification</b> | <b>Description</b>                                                           |
|---------------------------------------|------------------------------------------------------------------------------|
| OSHA Certification                    | 10-hour or greater OSHA safety card copies for all employees on-site         |
| Prevailing Wage Compliance            | Statement confirming 5-year compliance with the Illinois Prevailing Wage Act |
| Substance Abuse Program               | Copy of written program per 820 ILCS 265/1                                   |
| Workers' Compensation Policy          | Active policy and classification documentation                               |
| UI Act Registration                   | IDES current registration                                                    |
| Corporate Status                      | Illinois Secretary of State Business Services record                         |
| Tax and Legal Disclosures             | List of liens, judgments, or violations from the last 5 years                |
| Business Licenses                     | Copies of all relevant licenses with current status                          |
| Statement of Similar Projects         | Last 5 years' public works projects with references                          |
| Performance History                   | Public body contracts completed in the last 3 years                          |
| Subcontractor Information             | Full documentation for each subcontractor                                    |
| Sam.gov ID Number                     | ID Number to be used on projects with State or Federal Funding               |

If applicable, compliance documentation under:

- Davis-Bacon and Related Acts
- Employee Certification Act
- 720 ILCS 5/33-11 Anti-Bid Rigging Certification

Additional contractor responsibilities include:

- Submission of certified payrolls within five (5) working days of each pay period end
- Identification of all employees by name, address, craft, status, and hire date
- Documentation that all employees are properly classified and licensed
- Notification within two (2) business days of any resident employee resignations or terminations
- Replacement of Evanston resident employees within five (5) business days to avoid penalties
- Provision of required documentation prior to any subcontractor commencing work

Failure to meet these requirements may result in penalties of up to 1% of the approved project price and may jeopardize future eligibility for City contracts.

40. **PROJECT LABOR AGREEMENT NOTICE** (if required)

**A Project Labor Agreement (PLA) may be required. If so, all successful bidders must become signatories to the PLA for the duration of the project. There is no requirement to affiliate with a union, and non-union bidders are fully eligible.**

41. **QUESTIONS**

All questions related to this bid document should be submitted in writing to Tammi Nunez, Purchasing Specialist at [tnunez@cityofevanston.org](mailto:tnunez@cityofevanston.org) with a copy to Tim Kirkby, at [kirkby@cityofevanston.org](mailto:kirkby@cityofevanston.org). Only inquiries received a minimum of seven (7) working days prior to the date set for the opening of bids, will be given any consideration.

42. **COORDINATION OF EXISTING SITE WITH DRAWINGS**

- Before submitting a bid, bidders shall carefully examine the drawings and specifications, visit the site, and fully inform themselves as to all conditions and limitations.
- Should a bidder find discrepancies in, or omissions from the drawings or specifications, or should be in doubt as to their meaning, the bidder should at once notify the Purchasing Specialist, who will issue necessary instructions to all bidders in the form of an addendum.

43. **AFFIRMATIVE ACTION IN SUB-CONTRACTING (EXCERPT FROM RESOLUTION 59-R-73)**

“Contractor agrees that he shall actively solicit bids for the sub-contracting of goods or services from qualified minority businesses. At the request of the City, Contractor shall furnish evidence of his compliance with this requirement of minority solicitation. Contractor further agrees to consider the grant of sub-contracts to said minority bidders on the basis of substantially equal bids in the light most favorable to said minority businesses. Contractor further affirms that in obtaining his performance and bid bonds, he will seek out and use companies who have records of, and/or who will make commitments to, the bonding of minority contractors on a rate basis

comparable to their bonding of similar non-minority contractors. The contractor may be required to submit this evidence as part of the bid or subsequent to it.”

#### **44. COMPLIANCE WITH LAWS**

---

- A. The bidder shall at all times observe and comply with all laws, ordinances and regulations of the Federal, State, Local and City Governments, which may in any manner affect the preparation of bids or the performance of the contract.

#### **45. QUALIFICATION OF BIDDERS**

---

- A. All bidders must be qualified in accordance with the instructions, procedures and methods set forth in this specification.
  
- B. In awarding contract, City may take into consideration, skill, facilities, capacity, experience, ability, responsibility, previous work, financial standing of bidder, amount of work being carried on by bidder, quality and efficiency of construction equipment proposed to be furnished, period of time within which proposed equipment is furnished and delivered, necessity of prompt and efficient completion of work herein described. Inability of any bidder to meet requirements mentioned above may be cause for rejection of the bid. In addition, if the project covered by this contract is a minority set-aside project, the contractor's qualifications as a minority firm will determine the eligibility of the contractor to bid.

#### **46. COMPETENCY OF BIDDER**

---

- A. No bid will be accepted from or contract awarded to any person, firm or corporation that is in arrears or is in default to the City of Evanston upon any debt or contract, or that is a defaulter, as surety or otherwise, upon any obligation to said City, or had failed to perform faithfully any previous contract with the City.
  
- B. The bidder, if requested, must present within forty eight (48) hours evidence satisfactory to the Purchasing Manager of performance ability and possession of necessary facilities, pecuniary resources and adequate insurance to comply with the terms of these specifications and contract documents.

#### **47. PREFERENCE TO CITIZENS**

---

The Contractor shall abide by the Illinois Preference Act, 30 ILCS 570 et seq., which stipulates that whenever there is a period of excessive unemployment in Illinois, defined as any month immediately following two (2) consecutive months during which the level of unemployment in Illinois exceeds five percent (5%) as measured by the U.S. Bureau of Labor Statistics in its monthly publication of employment and unemployment figures, the Contractor shall employ only Illinois laborers unless otherwise exempted as so stated in the Act. (“Illinois laborer” means any person who has resided in Illinois for at least 30 days and intends to become or remain an Illinois resident) Other laborers may be used IF Illinois laborers are not available or are incapable of performing the particular type of work involved if so certified by the Contractor and approved by the project engineer.

## **GENERAL CONDITIONS**

### **1. BASIS OF AWARD**

---

The City of Evanston reserves the right to award a contract to a responsive and responsible Bidder(s) who submits the lowest total bid, or to reject any or all bids and bidding, when in its opinion the best interest of the City will be served by such action. The City reserves the right to consider the specified alternates in its evaluation of the bids.

### **2. BIDS**

---

#### **A. LUMP SUM BID**

1. The bidder is to submit a lump sum bid for each bid line on the Bid Form which includes all costs incidental to performing the specified work. It is understood and agreed that the unit quantities given in the supporting pages are approximate only and the bidder shall verify these quantities before bidding as no claim shall be made against the City on account of any excess or deficiency in the same.

2. Unit prices given in the supporting pages shall be used by the City and the Contractor for any subsequent changes in the contract.

### **3. QUANTITIES**

---

Any quantities shown on the Bid Form are estimated only for bid canvassing purposes, the City has made a good faith effort to estimate the quantity requirements for the Contract term. The City reserves the right to increase or decrease quantities ordered under this contract.

### **4. CONTRACT TERM**

---

Bidder must fully complete the work within the period specified herein after award of the contract by the City.

### **5. NOTICE TO PROCEED/ PURCHASE ORDER/ CONTRACT**

---

A. The City-issued Purchase Order serves as the City's official Notice to Proceed. No work will be allowed prior to the Contractor's receipt of the City-issued Purchase Order.

B. Upon approval of the required bonds and insurance documents, the City will issue a Purchase Order to the Contractor for the contract amount. All Applications for Payment must reference the Purchase Order number.

C. When it is necessary to issue a Change Order that increases/decreases the contract amount, a Change Order form will be issued, and a modified Purchase Order will be issued reflecting the revised contract amount.

D. When it is necessary to issue a Change Order that only increases/decreases the

contract period, only a Change Order form will be issued, establishing the revised contract period.

- E. Upon Award the contractor shall execute the Contractor Services Agreement.

## **6. PAYMENT**

---

- A. Progress payments will be made in accordance with “Applications for Payment” and “Project Closeout” sections of the specifications, **before 50% Completion**, less a 10% retainage for each payment; **at or after 50% Completion**, less a 5% retainage for each payment, which will be held until final acceptance of the work by the City. Certification of each Application for Payment will be made by the City’s representative.
- B. All payments will be made in accordance with the *Illinois Local Government Prompt Payment Act*.

## **7. DECISIONS TO WITHHOLD CERTIFICATION FOR PAYMENT**

---

- A. The City may not certify payment and may withhold payment in whole or in part, to the extent reasonably necessary to protect the City, if the quality of the work is not in accordance with the contract documents. If the City is unable to certify payment in the amount of the invoice, the City will promptly issue payment for the amount of the Work completed in accordance with the contract documents. The City may not certify payment due to any contractor negligence or contract non-compliance.
  - a. Defective work not remedied
  - b. Third party claims filed or reasonable evidence indicating probable filing of such claims
  - c. Failure of Contractor to make payments properly to Sub-contractors for labor, materials or equipment
  - d. Reasonable evidence that the work cannot be completed for the unpaid balance of the Contract Sum
  - e. Damage to the City or another contractor
  - f. Reasonable evidence that the work will not be completed within the Contract period and that the unpaid balance would not be adequate to cover actual or liquidated damages for the anticipated delay
  - g. Persistent failure to carry out work in accordance with the Contract Documents.

## **8. CHANGES IN WORK**

---

- A. The City reserves the right to make changes in the plans and specifications by altering, adding to, or deducting from the work, without invalidating the contract. All such changes shall be executed under the conditions of the original contract, except that any claim for extension of time caused thereby shall be adjusted at the time of ordering such change.
- B. No change shall be made unless a written Change Order and/or modified Purchase Order is issued by the City stating that the City has authorized the change, and no claim for an addition to the contract shall be valid unless so ordered.

- C. If such changes diminish the quantity of work to be done they shall not constitute a claim for damage or anticipated profits on the work, such increase shall be paid in one or more of the following ways:
  - 1. by estimate and acceptance in lump sum
  - 2. by unit prices named in the contract's bid form or subsequently agreed upon

**9. DEDUCTION FOR UNCORRECTED WORK**

---

If the City deems it expedient to correct work damaged or not done in accordance with the contract, the difference in value, together with a fair allowance for damage shall be deducted from the contract amount due. The value of such deduction shall be determined by the City.

**10. CITY'S RIGHT TO TERMINATE CONTRACT**

---

The City reserves the right, in addition to other rights to termination, to terminate the contracts in accordance with all provisions of the executed contract.

**11. LIENS**

---

- A. Neither the final payment nor any part of any retained percentages, shall become due until the contractor, if required, delivers to the City, a complete release of all liens arising out of this contract, or receipts in full in lieu thereof and, if required in either case, an affidavit that so far as it has knowledge or information the releases and receipts include all the labor and material for which a lien could be filed. If any lien remains unsatisfied after all payments are made the contractor shall refund to the City all moneys that the latter may be compelled to pay in discharging such a lien, including all costs and attorney's fees.

**12. SEPARATE CONTRACTS**

---

- A. The City reserves the right to let other contracts in connection with this work. The contractor shall afford other contractors' reasonable opportunity for the introduction and storage of their materials and the execution of their work and shall properly connect and coordinate his or her work with theirs. If any part of the contractor's work depends on proper execution or results upon the work of any other contractor, the contractor shall inspect and promptly report to the City any defects in such work that render it unsuitable for such proper execution and results. His or her failure to so inspect and report shall constitute an acceptance of other contractor's work as fit and proper.
- B. To insure the proper execution of his or her subsequent work, the contractor shall measure work already in place and shall at once report to the City any discrepancy between the executed work and the drawings which will affect his or her work.

**13. PROTECTION & SAFEGUARDS**

---

- A. Unless otherwise specified, the contractor, as a part of this contract, shall provide,

erect, and maintain temporary roads, fences, bracing, lights, warning signs, barricades, etc. necessary for the protection of the construction materials, adjacent property and the public.

- B. The contractor shall contact all utilities which will be affected by its operations and notify the owners of the utilities of its operations and their limits within forty-eight (48) hours prior to beginning construction. The contractor shall be responsible for damage to utilities and shall, at his or her own expense, restore such property to a condition equal to that which existed before its work, as may be directed by the owners.
- C. The contractor shall protect all work and unused materials of this contract from any and all damage and shall be solely responsible for the condition of such work and materials.

#### **14. MATERIAL STORAGE**

---

- A. On-site areas may be designated for material/equipment storage. The contractor will assume all risk and liability associated with the storage of material/equipment at on-site locations.

#### **15. CLEANING UP**

---

- A. The contractor shall at all time keep the premises free from accumulation of waste material or rubbish caused by its employees or work and at the completion of the work it shall remove all its rubbish, tools, and surplus materials from the premises, leaving the area in a neat and workmanlike condition. In case of dispute, the City may remove the rubbish and charge the cost to the contractor.
- B. Contractor recognizes that proper cleanup and removal of construction debris is an important safety consideration. The Contractor shall be solely responsible for daily construction site/area cleanup and removal of all construction debris in accordance with City-approved disposal practices. Contractor shall be solely responsible for identifying and removing at its expense all hazardous material and waste which it uses and generates.

#### **16. RESTORATION OF SITE**

---

- A. Prior to final payment, contractor shall fully restore all property disturbed or damaged during the course of this work. This includes, but is not limited to public property, (walks, curbs, roadways, trees, etc.) private property, and utilities. This shall also include removal of temporary facilities erected during the course of this contract and restoration of these areas.
- B. All restoration work shall be subject to the approval of the City and shall restore the property to a condition at least equal to that existing prior to the start of this contract.
- C. All restoration work of property damaged by contractor shall be accomplished at the sole expense of the contractor.

## 17. PREVAILING WAGE

---

- A. Prospective Bidders shall thoroughly familiarize themselves with the provisions of the above-mentioned Act and shall prepare any and all bids/bids in strict compliance therewith.
- B. **Effective September 1st - All work performed on new and existing projects must be submitted to the Illinois Department of Labor through the certified transcript of the payroll portal.** You may access the portal here:  
[Certified Transcript of Payroll Portal](#)

All contractors and sub-contractors on public works projects **must submit and upload certified payrolls** on a monthly basis to the IDOL online portal, provide a pdf copy to the City's project manager and business work force development coordinator, along with a statement affirming that such records are true and accurate, that the wages paid to each worker are not less than the required prevailing rate and that the contractor is aware that filing records her or she knows to be false is a Class B misdemeanor.

- C. The certified payroll record must include for every worker employed on the public works project the name, address, telephone number, social security number, job classification, hourly wages paid in each pay period, number of hours worked each day, and starting and ending time of work each day. These certified payroll records are considered public records and public bodies must make these records available to the public under the Freedom of Information Act, with the exception of the employee's address, telephone number and social security number. Any contractor who fails to submit a certified payroll or knowingly files a false certified payroll is guilty of a Class B misdemeanor.
- D. All certified payrolls shall be submitted in electronic format, preferably a PDF file.
- E. As a condition of receiving payment, Contractor must (i) be in compliance with the Agreement, (ii) pay its employees prevailing wages when required by law (Examples of prevailing wage categories include public works, printing, janitorial, window washing, building and grounds services, site technician services, natural resource services, security guard and food services). Contractor is responsible for contacting the Illinois Dept. of Labor 217-782-1710; <https://www2.illinois.gov/idol/Laws-Rules/CONMED/Pages/prevailing-wage-act.aspx> compliance with prevailing wage requirements), (iii) pay its suppliers and sub-contractors according to the terms of their respective contracts, and (iv) provide lien waivers to the City upon request.

## 18. CONTRACTOR REQUIREMENTS

---

- A. The Contractor shall abide by and comply with all local, State and federal laws and regulations relating to contracts involving public funds and the development/construction of public works, buildings, or facilities. The scale of wages to be paid shall be obtained from Illinois Department of Labor and posted by the

Contractor in a prominent and accessible place at the project work site.

- B. The Contractor certifies it has not been barred from being awarded a contract with a unit of State or local government as a result of bid rigging or bid rotating or any similar offense (720 ILCS 5/33 E-3, E-4).
- C. The Contractor certifies, pursuant to the Illinois Human Rights Act (775 ILCS 5/2-105), that it has a written sexual harassment policy that includes, at a minimum, the following information: (1) the illegality of sexual harassment, (2) the definition of sexual harassment under State law, (3) a description of sexual harassment utilizing examples, (4) the Contractor's internal complaint process including penalties, (5) legal recourse, investigation and complaint process available through the Illinois Department of Human Rights and the Human Rights Commission and directions on how to contact both; and (6) protection against retaliation as provided by Section 6-101 of the Illinois Human Rights Act.
- D. The Contractor shall abide by the "Illinois Preference Act" which stipulates that whenever there is a period of excessive unemployment in Illinois, defined as any month immediately following two (2) consecutive months during which the level of unemployment in Illinois exceeds five percent (5%) as measured by the U.S. Bureau of Labor Statistics in its monthly publication of employment and unemployment figures, the Contractor shall employ only Illinois laborers unless otherwise exempted as so stated in the Act. ("Illinois laborer" means any person who has resided in Illinois for at least 30 days and intends to become or remain an Illinois resident) Other laborers may be used IF Illinois laborers are not available or are incapable of performing the particular type of work involved if so certified by the Contractor and approved by the project engineer.

## **19. SUB-CONTRACTORS**

- A. The term "sub-contract" means any agreement, arrangement or understanding, written or otherwise between a Contractor and any person (in which the parties do not stand in the relationship of an employer or an employee) for the furnishing of supplies or services or for the use of real or personal property, including lease arrangements, which, in whole or in part, is utilized in the performance of any one or more Contracts under which any portion of the Contractor's obligation under any one or more Contracts is performed, undertaken or assumed.
- B. The Bidder is specifically advised that any person, firm or party, to whom it is proposed to award a sub-contract under this contract must be acceptable to the City. Approval for the proposed sub-contract Award cannot be given by the City until the proposed Sub-contractor has submitted evidence showing that it has fully complied with any reporting requirements to which it is, or was, subject.
- C. The contractor, shall, within ten (10) days after award of the Contract, submit to the City in writing, names and addresses and respective amounts of money for proposed contracts with Sub-contractors/major suppliers. The City will review and

may direct the Contractor that they shall not employ any that are not acceptable as provided above.

- D. The sub-contractor shall abide by and comply with all local, State and federal laws and regulations relating to contracts involving public funds and the development/construction of public works, buildings, or facilities.

## **20. PAYMENTS TO SUB-CONTRACTORS**

---

- A. Within seven days after the receipt of amounts paid by the City for work performed by a sub-contractor under this contract, the Contractor shall either:
  - 1. Pay the sub-contractor for the proportionate share of the total payment received from the City attributable to the work performed by the sub-contractor under this contract; or,
  - 2. Notify the City and sub-contractor, in writing, of his intention to withhold all or a part of the sub-contractor's payment and the reason for non-payment.
- B. The Contractor shall pay interest to the sub-contractor on all amounts owed that remain unpaid beyond the seven-day period except for amounts withheld as allowed in item 2 above.
- C. Unless otherwise provided under the terms of this contract, interest shall accrue at the rate of one percent per month.
- D. The Contractor shall include in each of its sub-contracts a provision requiring each Sub-contractor to include or otherwise be subject to the same payment and interest requirements as set forth above with respect to each lower-tier sub-contractor.
- E. The Contractor's obligation to pay an interest charge to a sub-contractor pursuant to this provision may not be construed to be an obligation of the City.

## **21. BOND – PERFORMANCE, MATERIAL, & LABOR**

---

- A. When required by the specifications herein, the successful Bidder or Bidders shall, within ten (10) calendar days after acceptance of the Bidder's bid by the City, furnish a performance bond for 100% of the full amount of the contract from insurance companies having not less than A+ Policyholders Rating from the most recent Alfred M. Best and Co., Inc. listing available. Certification of the insurance company's rating shall be provided prior to contract implementation and quarterly thereafter until contract completion. Should such rating fall below the required A+ level during performance of the contract, it will be the contractor's responsibility to notify the City and provide a new bond from an insurance company whose rating meets the City's requirements.
- B. When required by the specifications herein, all Bidders shall submit with the bid a

bid bond. A letter of credit may be furnished in lieu of a bid bond only if the following conditions are met: 1) An irrevocable letter of credit must be obtained from an accredited bank which shall include an agreement that the bank will honor a demand by the City for payment due to Plaintiff failure to complete the project. 2) An irrevocable letter of credit must be in writing and signed by an authorized representative of the bank. 3) The irrevocable letter of credit must expressly state that it is irrevocable until the bid has been awarded. 4) The letter of credit must be for the percentage specified in the bid documents.

- C. The City may reject the use of an irrevocable letter of credit if the financial soundness of the issuing bank is found to be unacceptable.
- D. In the event that the Bidder fails to furnish a performance bond in said period of ten (10) calendar days after acceptance of the Bidder's bid by the City, the City may withdraw its acceptance of the bid and retain the Bidder's deposit as liquidated damages and not as a penalty.
- E. If the contractor has more than one project for which there is a contract with the City of Evanston, the contractor shall provide a separate Performance Bond for each project.

## **22. INDEMNITY**

---

- A. The Contractor shall defend, indemnify and hold harmless the City and its officers, elected and appointed officials, agents, and employees from any and all liability, losses, or damages as a result of claims, demands, suits, actions, or proceedings of any kind or nature, including but not limited to costs, and fees, including attorney's fees, judgments or settlements, resulting from or arising out of any negligent or willful act or omission on the part of the Contractor or Contractor's sub-contractors, employees, agents or sub-contractors during the performance of this Agreement. Such indemnification shall not be limited by reason of the enumeration of any insurance coverage herein provided. This provision shall survive completion, expiration, or termination of this Agreement.
- B. Nothing contained herein shall be construed as prohibiting the City, or its officers, agents, or employees, from defending through the selection and use of their own agents, attorneys, and experts, any claims, actions or suits brought against them. The Contractor shall be liable for the reasonable costs, fees, and expenses incurred in the defense of any such claims, actions, or suits. Nothing herein shall be construed as a limitation or waiver of defenses available to the City and employees and agents, including but not limited to the Illinois Local Governmental and Governmental Employees Tort Immunity Act, 745 ILCS 10/1-101 *et seq.*
- C. At the City Corporation Counsel's option, Contractor must defend all suits brought upon all such Losses and must pay all costs and expenses incidental to them, but the City has the right, at its option, to participate, at its own cost, in the defense of any suit, without relieving Contractor of any of its obligations under this Agreement.

Any settlement of any claim or suit related to this Project by Contractor must be made only with the prior written consent of the City Corporation Counsel, if the settlement requires any action on the part of the City.

- D. To the extent permissible by law, Contractor waives any limits to the amount of its obligations to indemnify, defend, or contribute to any sums due under any Losses, including any claim by any employee of Contractor that may be subject to the Illinois Workers Compensation Act, 820 ILCS 305/1 et seq. or any other related law or judicial decision, including but not limited to, Kotecki v. Cyclops Welding Corporation, 146 Ill. 2d 155 (1991). The City, however, does not waive any limitations it may have on its liability under the Illinois Worker Compensation Act, the Illinois Pension Code or any other statute.
- E. The Contractor shall be responsible for any losses and costs to repair or remedy work performed under this Agreement resulting from or arising out of any act or omission, neglect, or misconduct in the performance of its Work or its sub-contractors' work. Acceptance of the work by the City will not relieve the Contractor of the responsibility for subsequent correction of any such error, omissions and/or negligent acts or of its liability for loss or damage resulting therefrom.

### **23. CONTRACTOR'S LIABILITY INSURANCE**

---

- A. THE CONTRACTOR SHALL NOT COMMENCE WORK UNDER THIS CONTRACT UNTIL THEY HAVE OBTAINED ALL INSURANCE REQUIRED HEREIN AND SUCH INSURANCE HAS BEEN APPROVED BY THE CITY. Nor shall the contractor allow any sub-contractor to commence work until all similar insurance required of the sub-contractor has been so obtained.
- B. The City of Evanston shall be named as an additional insured on the policy of the contractor for whatever the policy limits are for the contractor, but in no event shall the Comprehensive General Liability limits be less than \$3,000,000.00.
- C. If the contractor has more than one project for which he has a contract with the City of Evanston, there shall be separate Certificates of Insurance naming the City as an additional insured on each separate policy.
- D. In the event of accidents, injuries, or unusual events, whether or not any injury occurred, the contractor shall promptly furnish the City with copies of all reports of such incidents.
- E. The contractor shall furnish one (1) copy of a certificate, with the City named as an additional insured, showing the following minimum coverage with an insurance company acceptable to the City.

### **24. PRE-CONSTRUCTION MEETING**

---

- A. A pre-construction meeting will be scheduled for the successful Contractor at a

date immediately following the awarding of the Contracts.

## **25. LIQUIDATED DAMAGES**

---

- A. The Contractor shall, and agrees to pay, per calendar day, the amount listed in the Schedule of Deductions presented in Article 108.09 of the Standard Specifications (based upon the total Contract Price) as liquidated damages for failure to meet the completion deadlines identified below:

Substantial Completion Deadline: October 5, 2026

Final Completion Deadline: October 26, 2026

- B. Substantial Completion shall be defined as the stage in the progress of the work when the work or designated portion thereof is sufficiently complete in accordance with the Contract Documents so that the City can occupy or utilize the work for its intended use. Substantial Completion will be certified by the issuance of a Certificate of Substantial Completion, to be issued by the City's representative, when the Contractor has satisfied the above statement.
- C. Final Completion shall be defined as the stage in the progress of the work when all work on site is fully complete, including punch list work, with the exception of restoration grass establishment.

## **26. EXTENSION OF TIME**

---

- A. Delays due to causes beyond the control of the contractor other than such as reasonable would be expected to occur in connection with or during the performance of the work, may entitle the contractor to an extension of time for completing the work sufficient to compensate for such delay. No extension of time shall be granted, however, unless the contractor shall notify the City in writing thereof, within ten (10) days from the initiation of the delay and unless he shall, within ten (10) days after the expiration of the delay, notify the City in writing of the extension of time claimed on account thereof and then only to the extent, if any, allowed by the City.

## **27. DEFAULT**

---

- A. The City may, subject to the provisions of this section, by written notice of default to Contractor, terminate the whole or any part of this contract in any one of the following circumstances:
1. if the Contractor fails to perform the services within the time specified herein, or any extension thereof; or
  2. if the contractor fails to perform any of the other provisions of this contract, or so fails to make progress as to endanger performance of this contract in accordance with its terms, and in either of these two circumstances does not cure failure within a period of 10 days (or such other extended period as the City may authorize in writing) after receipt of notice from the City specifying such failure

- B. In the event the City terminates this contract in whole or in part as provided in this section, the City may procure, upon such terms and in such manner as the City may deem appropriate, services similar to those so terminated, and the Contractor will be liable to the City for any excess costs for such similar services.
- C. The Contractor will not be liable for any excess of costs if acceptable evidence has been submitted to the City that the failure to perform the contract was due to causes beyond the control and without fault or negligence of the Contractor.
- D. Contractors who default may not be considered for awards of future City contracts.

**28. USE OF PREMISES**

---

- A. The contractor shall confine his apparatus, the storage of materials and the operations of his workers, to limits indicated by law, ordinances, permits or directions of the City.

**29. DISCLOSURES AND POTENTIAL CONFLICTS OF INTEREST (30 ILCS 500/50-35)**

---

- A. The City of Evanston's Code of Ethics prohibits public officials or employees from performing or participating in an official act or action with regard to a transaction in which he has or knows he will thereafter acquire an interest for profit, without full public disclosure of such interest. This disclosure requirement extends to the spouse, children and grandchildren, and their spouses, parents and the parents of a spouse, and brothers and sisters and their spouses.

To ensure full and fair consideration of all bids, the City of Evanston requires all Bidders including owners or employees to investigate whether a potential or actual conflict of interest exists between the Bidder and the City of Evanston, its officials, and/or employees. If the Bidder discovers a potential or actual conflict of interest, the Bidder must disclose the conflict of interest in its bid, identifying the name of the City of Evanston official or employee with whom the conflict may exist, the nature of the conflict of interest, and any other relevant information. The existence of a potential or actual conflict of interest does NOT, on its own, disqualify the disclosing Bidder from consideration. Information provided by Bidders in this regard will allow the City of Evanston to take appropriate measures to ensure the fairness of the bidding process.

The City of Evanston requires all bidders to submit a certification, enclosed with this bid packet, that the bidder has conducted the appropriate investigation and disclosed all potential or actual conflicts of interest.

By submitting a bid, all Bidders acknowledge and accept that if the City of Evanston discovers an undisclosed potential or actual conflict of interest, the City of Evanston may disqualify the Bidder and/or refer the matter to the appropriate authorities for investigation and prosecution.

**INSURANCE REQUIREMENTS**

| <b><u>TYPE OF INSURANCE</u></b>                                                                                                                                | <b><u>MINIMUM INSURANCE COVERAGE</u></b> |                                                                                                             |
|----------------------------------------------------------------------------------------------------------------------------------------------------------------|------------------------------------------|-------------------------------------------------------------------------------------------------------------|
|                                                                                                                                                                | Consequent Death                         | Bodily Injury and<br>Property Damage                                                                        |
|                                                                                                                                                                | Each Occurrence                          | Aggregate                                                                                                   |
| Commercial General Liability including:                                                                                                                        | \$3,000,000                              | \$3,000,000                                                                                                 |
| 1. Comprehensive form                                                                                                                                          |                                          |                                                                                                             |
| 2. Premises - Operations                                                                                                                                       |                                          |                                                                                                             |
| 3. Explosion & Collapse Hazard                                                                                                                                 |                                          |                                                                                                             |
| 4. Underground Hazard                                                                                                                                          |                                          |                                                                                                             |
| 5. Products/Completed Operations<br>Hazard                                                                                                                     |                                          |                                                                                                             |
| 6. Contractual Insurance – With<br>an endorsement on the<br>face of the certificate<br>that it includes the<br>"Indemnity" paragraph<br>of the specifications. |                                          | <b><u>Insurance Certificate Must State:<br/>The City Of Evanston is Named<br/>as Additional Insured</u></b> |
| 7. Broad Form Property Damage -<br>construction projects only                                                                                                  |                                          |                                                                                                             |
| 8. Independent contractors                                                                                                                                     |                                          |                                                                                                             |
| 9. Personal Injury                                                                                                                                             |                                          |                                                                                                             |
| Automobile Liability<br>Owned, Non-owned or Rented                                                                                                             | \$ 1,000,000                             | \$1,000,000                                                                                                 |
| Workmen's Compensation<br>and Occupational Diseases<br>As required by applicable laws.<br>Employer's Liability                                                 |                                          | \$ 500,000                                                                                                  |

Thirty-day notice of cancellation required on all certificates.

**EXHIBIT A – BID FORM**  
**For**  
**Levy Center Kitchen Remodel**

**(BID #26-29)**

1.01 BID TO:

**THE CITY OF EVANSTON**  
909 Davis Street  
Evanston, Illinois 60201

Hereinafter called "OWNER".

1.02 BID FROM:

---

(Hereinafter call "BIDDER")

---

Address

---

Telephone Number

---

Fax Number

1.03 BID FOR: **Levy Center Kitchen Remodel**

1.04 ACKNOWLEDGEMENT:

A. The Bidder, in compliance with the Invitation for Bids, having carefully examined the Drawings and Project Manual with related documents and having visited the site of the proposed Work, and being familiar with all of the existing conditions and limitations surrounding the construction of the proposed project, including the structure of the ground, subsurface conditions, the obstacles which may be encountered, local restrictions, and all other relevant matters concerning the Work to be performed, hereby PROPOSES to perform everything required to be performed, and to provide all labor, materials, necessary tools and equipment, expendable equipment, all applicable permits and taxes and fees, and provide all utility and transportation services necessary to perform and complete in a workmanlike

manner the Project in accordance with all the plans, specifications and related Contract Documents as prepared by the City of Evanston.

- B. The undersigned hereby acknowledges receipt of Invitation of Bids, Instruction to Bidder, the Project Manual, Drawings, and other Contract Documents and acknowledges receipt of the following Addenda:

Addendum No. \_\_\_\_\_ Dated \_\_\_\_\_

Addendum No. \_\_\_\_\_ Dated \_\_\_\_\_

Addendum No. \_\_\_\_\_ Dated \_\_\_\_\_

#### 1.05 GENERAL STATEMENTS

- A. The undersigned has checked all of the figures contained in this proposal and further understands that the Owner will not be responsible for any errors or omissions made therein by the undersigned.
- B. It is understood that the right is reserved by the Owner to reject any or all proposals, to waive all informality in connection therewith and to award a Contract for any part of the work or the Project as a whole.
- C. The undersigned declares that the person(s) signing this proposal is/are fully authorized to sign on behalf of the named firm and to fully bind the named firm to all the conditions and provisions thereof.
- D. It is agreed that no person(s) or company other than the firm listed below or as otherwise indicated hereinafter has any interest whatsoever in this proposal or the Contract that may be entered into as a result thereof, and that in all respects the proposal is legal and fair, submitted in good faith, without collusion or fraud.
- E. It is agreed that the undersigned has complied and/or will comply with all requirements concerning licensing and with all other local, state and national laws, and that no legal requirement has been or will be violated in making or accepting this proposal, in awarding the Contract to him, and/or in the prosecution of the Work required hereunder.
- F. To be considered a bona fide offer, this proposal must be completed in full and accompanied by a bid deposit or a bid bond when required by Contract Documents or Addenda.

#### 1.06 ALTERNATES

- A. When alternate proposals are required by Contract Documents or Addenda thereto, the undersigned proposes to perform alternates for herein stated additions to or deductions from hereinbefore stated Base Bid. Additions and deductions include all modifications of Work or additional Work that the undersigned may be required to perform by reason of the acceptance of alternates.

1.07 ALLOWANCE

The allowance is intended to address items not able to be precisely determined prior to bidding including unforeseen conditions that are discovered during the course of construction. At the end of the project, unspent allowance shall be credited to owner via change order. See Section 01 21 00 – Allowances for additional information.

1.08 AGREEMENT

- A. In submitting this Bid, the undersigned agrees:
  - 1. To hold this Bid open for sixty (60) days from the submittal date.
  - 2. To enter into and execute a Contract with the Owner within ten (10) days after receiving Notice of Award from the Owner.
  - 3. To accomplish the work in accordance with the Contract Documents.
  - 4. To complete the work by the time stipulated in the General Conditions
- B. The Owner reserves the right to reject any and all Bids and to waive any informalities in Bidding.

1.09 SCHEDULE

- A. See General Conditions for the required schedule of completion dates.

1.10 PROPOSED PRICES

- A. The Bidder hereby proposes to furnish all labor, materials, equipment, transportation, construction plant, and facilities necessary to complete, in a workmanlike manner and in accordance with the contract documents, the contract of work bid upon herein for compensation in accordance with the following prices:

**BASE BID AMOUNT:** \$ \_\_\_\_\_

**ALLOWANCE (ADDITIONAL WORK – GENERAL):** \$ \_\_\_\_\_ +25,000

**TOTAL BASE BID AMOUNT:** \$ \_\_\_\_\_

**ALTERNATE 1 –**

The ADD/DEDUCT LUMP SUM PRICE, if awarded to the undersigned, shall be:

**ALTERNATE 1 AMOUNT:** \$ \_\_\_\_\_

**ALTERNATE 2 –**

The ADD/DEDUCT LUMP SUM PRICE, if awarded to the undersigned, shall be:

**ALTERNATE 2 AMOUNT:** \$ \_\_\_\_\_

1.11 UNIT PRICING LIST

N/A

1.12 BID SECURITY

If required by the bid documents, a scanned copy of the bid bond must be included with the bid electronic submission. The City is currently not able to accept a certified check, bank cashier's check or electronic bid bond at this time.

- A. The City of Evanston Civic Center is unable to receive in person drop-off and it is closed to the public. The original bid bond must be mailed within ten (10) days after the due date, to the City of Evanston Purchasing Department, 909 Davis Street, Evanston, Illinois 60201 Attention Purchasing Manager using the USPS (certified or priority), UPS or FedEx mail options in order to have a tracking number.
- B. Accompanying this electronic submittal is a scanned copy of a bank draft, bid bond, Cashier's check or Certified check as surety in the amount of not less than five percent (5%) of the Total Bid payable to the City of Evanston.

The amount of the check or draft is: \$ \_\_\_\_\_

If this bid is accepted and the undersigned shall fail to execute a contract and contract bond as required it is hereby agreed that the amount of the check or draft or bidder's bond substituted in lieu thereof, shall become the property of the City and shall be considered as payment of damages due to delay and other causes suffered by the City because of the failure to execute said contract and contract bond; otherwise said check or draft shall be returned to the undersigned.

In the event that one check or draft is intended to cover two or more bids, the amount must be equal to the sum of the project proposal guarantees of the individual sections covered.

If the check or draft is placed on another project proposal, state below where it may be found, as follows: The check or draft will be found in the project proposal for:

\_\_\_\_\_.

1.13 PERFORMANCE/PAYMENT BOND

The undersigned bidder agrees to provide Performance Bond and Payment Bond executed in accordance with the Contract Performance Bond form furnished by and acceptable to the Owner, written with \_\_\_\_\_

\_\_\_\_\_ in the amount of 100% of the Contract Sum (Total Base Bid and all accepted alternatives and adjustments) the cost of which is included in the Bid.

Cost of bond for change order is \_\_\_\_\_ percent of change order cost.

1.14 LIQUIDATED DAMAGES

The undersigned Bidder understands and agrees to the provisions stated under "LIQUIDATED DAMAGES" in the General Conditions and shall be assessed at the specified daily rate for each calendar day or partial calendar day until completion as defined herein.

1.15 MATERIAL SUBSTITUTION SHEET

The following is a schedule of substitute materials I propose to furnish on this job, with the difference in price being added to or deducted from the Base Bid. The Base Bid is understood to include only those items which are definitely specified by trade names or otherwise.

I understand that if no price difference is indicated, then the selection of materials is optional with the Owner, and approval or rejection of the substitution below will be indicated prior to signing of Contracts.

| <u>PRODUCT NAME AND/OR MANUFACTURER</u> | <u>ADD</u> | <u>DEDUCT</u> |
|-----------------------------------------|------------|---------------|
| _____                                   | _____      | _____         |
| _____                                   | _____      | _____         |
| _____                                   | _____      | _____         |

1.16 PROPOSAL SIGNATURE (REQUIRED)

A. SOLE PROPRIETOR

Signature of Bidder: \_\_\_\_\_

SUBSCRIBED AND SWORN to before me this \_\_\_\_\_ day of \_\_\_\_\_, 20\_\_

\_\_\_\_\_  
Notary Public

Commission Expires: \_\_\_\_\_

B. PARTNERSHIP

Signature of All Partners: \_\_\_\_\_

\_\_\_\_\_  
Name (typed or printed)

\_\_\_\_\_  
Name (typed or printed)

SUBSCRIBED AND SWORN to before me this \_\_\_\_ day of \_\_\_\_\_, 20\_\_

\_\_\_\_\_  
Commission Expires: \_\_\_\_\_

Notary Public

C. CORPORATION

Signature of Authorized Official: \_\_\_\_\_

Title: \_\_\_\_\_

Name above (typed or printed): \_\_\_\_\_

(If other than the president, attach a certified copy of that section of corporate by-laws or other authorization by the Corporation which permits the person to execute the offer for the Corporation.)

(Corporate Seal)

Attest: \_\_\_\_\_

Secretary

SUBSCRIBED AND SWORN to before me this \_\_\_\_ day of \_\_\_\_\_, 20\_\_

\_\_\_\_\_  
Commission Expires: \_\_\_\_\_

Notary Public

1.17 DISCLOSURE

- A. The undersigned duly sworn deposes and says on oath that the bidder has withheld no disclosures of ownership interest and the information provided herein to the best of its knowledge is current and said undersigned has not entered into any agreement with any other bidder or prospective bidder or with any other person, firm or corporation relating to the price named in said proposal or any other proposal, nor any agreement or arrangement under which any person, firm or corporation is to refrain from bidding, nor any agreement or arrangement for any act or omission in restraint of free competition among bidders and has not disclosed to any person, firm or corporation the terms of this bid or the price named herein.

Bidder: \_\_\_\_\_

Business Address: \_\_\_\_\_

\_\_\_\_\_

Telephone Number: \_\_\_\_\_

1.18 CONTACTS

- A. In the event the Evanston City Council approves this bid response, list the name, address, telephone, and fax number of the person to be contacted:

Bidder: \_\_\_\_\_

Address: \_\_\_\_\_

\_\_\_\_\_

Telephone Number: \_\_\_\_\_

Fax Number: \_\_\_\_\_

1.19 REFERENCES

A. Provide three (3) references for which your firm has completed work of a similar scope in the past.

1. Name: \_\_\_\_\_

Address: \_\_\_\_\_

Contact Person: \_\_\_\_\_

Phone: \_\_\_\_\_

Contract Value: \_\_\_\_\_

Contract Dates: \_\_\_\_\_

2. Name: \_\_\_\_\_

Address: \_\_\_\_\_

Contact Person: \_\_\_\_\_

Phone: \_\_\_\_\_

Contract Value: \_\_\_\_\_

Contract Dates: \_\_\_\_\_

3. Name: \_\_\_\_\_

Address: \_\_\_\_\_

Contact Person: \_\_\_\_\_

Phone: \_\_\_\_\_

Contract Value: \_\_\_\_\_

Contract Dates: \_\_\_\_\_

**EXHIBIT B**

**RBO COMPLIANCE CERTIFICATION**

[Company Letterhead]

**City of Evanston – Bid Compliance Certification**

We hereby certify that [Company Name] is in full compliance with the requirements set forth under Ordinance 1-O-26, attached hereto, including but not limited to all applicable provisions under Section 1-17-1 of the Evanston City Code.

Our company has reviewed and will adhere to:

- The Local Employment Program (LEP), including the hiring of Evanston residents and achieving 15% of project hours performed by said residents.
- The Apprenticeship Training Program requirement, with attached documentation of program participation and graduation rates.
- The prohibition on excessive pass-through subcontracting; we will perform a minimum of 25% of the contracted work directly.
- All certification and documentation obligations outlined in the ordinance.

Signed: \_\_\_\_\_

Name: \_\_\_\_\_

Title: \_\_\_\_\_

Company Name: \_\_\_\_\_

Project Title: \_\_\_\_\_

Project Number: \_\_\_\_\_

Date: \_\_\_\_\_

**EXHIBIT B**

**RBO COMPLIANCE CERTIFICATION**

[Company Letterhead]

**City of Evanston – Legal & Regulatory Compliance Certification**

I, [Authorized Representative Name], hereby certify that [Company Name] complies with and has provided documentation for each of the following:

- Illinois Prevailing Wage Act (past 5 years; no violations)
- Substance Abuse Prevention on Public Works Project Act (written policy included)
- Workers' Compensation Act (policy attached, correct classification)
- Unemployment Insurance Act (IDES registration included)
- Employee Classification Act
- Davis-Bacon Act (if applicable)
- Registered in Sam.Gov (if applicable)
- Unique Entity Identifier (UEI) (if applicable)
- Corporate good standing with the Illinois Secretary of State
- Illinois Department of Revenue registration
- No federal, state, or local tax liens or delinquencies within the past 5 years
- Disclosure of any violations or determinations by federal or state authorities related to contracting, safety, tax, licensing, or labor laws.

Signed: \_\_\_\_\_

Name: \_\_\_\_\_

Title: \_\_\_\_\_

Project Title: \_\_\_\_\_

Project Number: \_\_\_\_\_

Date: \_\_\_\_\_

**EXHIBIT B**

**RBO COMPLIANCE CERTIFICATION**

[Subcontractor Letterhead]

City of Evanston – Subcontractor Compliance Certification

Subcontractor Name: \_\_\_\_\_

Prime Contractor: \_\_\_\_\_

Project Title: \_\_\_\_\_

Project Number: \_\_\_\_\_

I hereby certify that [Subcontractor Name] will comply with all City of Evanston ordinance requirements applicable to public works contracts, including Local Employment Program provisions, Apprenticeship Program participation, and regulatory compliance obligations listed under Ordinance 1-O-26.

All documentation and certifications have been submitted to the prime contractor and will be furnished to the City upon request.

Signed: \_\_\_\_\_

Name: \_\_\_\_\_

Title: \_\_\_\_\_

Date: \_\_\_\_\_

## EXHIBIT C

### **CITY OF EVANSTON LOCAL EMPLOYMENT PROGRAM (LEP) COMPLIANCE**

**Effective Date January 1, 2015**

#### **City of Evanston Ordinance 60-O-14, Local Employment Program (LEP) Penalties:**

**Ordinance 60-O-14**, Amendment to the MWDEBE/LEP revising the penalty section from a \$100/per day to a 1.0% of total project value penalty can be found at: Ordinance 60-O-14 Amendment MWEDBE LEP of the Evanston City Code Section 1-17-1 (C) can be found at Municode Library. The following are excerpts from Ordinance 60-O-14, Amending City Code Section 1-17-1(C) (11): Penalty.

**If the contractor or sub-contractor fails to comply:** The City may impose a fine up to one percent (1.0%) of the approved project price in total. Contractors or sub-contractors that are out of compliance due to a resident termination or resignation shall immediately notify the Business Workforce Compliance Coordinator of this occurrence within two (2) business days. Subsequently, the contractor or sub-contractor shall have five (5) additional business days to replace a terminated or resigned worker with another resident.

**If the contractor or sub-contractor fails to comply:** If the contractor or sub-contractor fails to make the replacement or to notify the Business Workforce Compliance Coordinator of this occurrence, the offending party will also be subject to a penalty up to one percent (1.0%) of the approved project price. If the noncompliant contractor makes a good faith effort to replace the resident, the fine may be waived.

**If the contractor or sub-contractor fails to comply:** At the sole discretion of the City, a contractor or sub-contractor that has violated the terms of the Local Employment Program within a three-year period may be determined a non-responsible bidder and excluded from bidding on future projects for a period of not less than one year.

**If the employee (LEP Evanston resident) fails to comply:** At the sole discretion of the City, an employee that has been hired through the LEP may be removed from the program for a period of not less than one year for failing to adhere to program guidelines or due to termination by the contractor for cause. Such termination process will be reviewed by the Workforce Development Coordinator.

**\*\*Detailed Local Employment Program Instructions “How to Comply” can be found at: [Local Employment Program Detailed Instructions](#)**

**Local Employment Program or Exhibit F Questions:** City staff is available for assistance to help with compliance. Submit questions in writing to Jessica Cooper, the Workforce Development Coordinator at [jcooper@cityofevanston.org](mailto:jcooper@cityofevanston.org) or Tammi Nunez, Purchasing Manager at [tnunez@cityofevanston.org](mailto:tnunez@cityofevanston.org).

**EXHIBIT C**

**LOCAL EMPLOYMENT PROGRAM COMPLIANCE**  
**CITY CODE SECTION 1-17-1(C): LOCAL EMPLOYMENT PROGRAM**

I have read and understood the requirements of the City of Evanston Local Employment Program ("LEP") as set forth in City of Evanston Code Section 1-17-1(C): Local Employment Program. I intend to comply with the program as follows:

Estimated total labor cost = \$ \_\_\_\_\_ 15% of total labor cost = \$ \_\_\_\_\_

- \_\_\_\_\_ My total bid, including all alternates, is under \$250,000, and the LEP does not apply.
- \_\_\_\_\_ My total bid, including all alternates, is equal to or greater than \$250,000, and I already employ, and will continue to employ for the duration of the contract for which I am submitting this bid, Evanston residents (residing in zip codes 60201 or 60202) for at least 15% of all hours worked at the construction site by construction trade workers.
- \_\_\_\_\_ My total bid, including all alternates, is equal to or greater than \$250,000, and I will employ, for the duration of the contract for which I am submitting this bid, through use of the City of Evanston database or otherwise, Evanston residents (residing in zip codes 60201 or 60202) for at least 15% of all hours worked at the construction site by construction trade workers.
- \_\_\_\_\_ My total bid, including all alternates, is equal to or greater than \$250,000, and I have been unable to comply with the LEP requirements but am willing to work with the City to achieve compliance.
- \_\_\_\_\_ My total bid, including all alternates, is equal to or greater than \$250,000, and after having made sincere attempt to comply as noted below, I seek a waiver on a portion or all of the LEP requirements on this contract. Complete next section "Reasons for Waiver Request" below.

**I UNDERSTAND THAT FAILURE TO COMPLY WITH THE LEP, REGARDLESS OF INTENT, MAY RESULT IN MAXIMUM PENALTY AS SET FORTH IN CITY CODE SECTION 1-17-1(C)(11), AS AMENDED.**

**WAIVER WILL BE GRANTED ONLY AFTER SINCERE ATTEMPT TO COMPLY\***

REASONS FOR WAIVER REQUEST: PLEASE CHECK ALL THAT APPLY AND COMPLETE INFORMATION REQUESTED:

- 1. I have made a sincere attempt as otherwise indicated below but have nonetheless been unable to comply.
  - a. I do or will employ Evanston residents for the project, but such employment amounts to \_\_\_\_% of total labor cost.
- 2. The nature of the job is so technical that, after having made a sincere attempt as otherwise indicated below, I have been unable to locate any Evanston residents qualified to perform any aspects of the work. Please describe applicable job requirements/qualifications. Attach separate sheet if necessary:

\_\_\_\_\_

\*THE FOLLOWING DEMONSTRATE **SINCERE ATTEMPT TO COMPLY**: PLEASE CHECK EACH BOX COMPLETED, AS APPLICABLE:

- 3. I have utilized the local resident database and otherwise worked with the City in an attempt to hire Evanston residents in compliance with LEP on this project, and have nonetheless been unable to comply;
- 4. I have placed one or more ads in a local newspaper seeking to hire Evanston residents in compliance with LEP on this project, and have nonetheless been unable to comply; and
- 5. If I am utilizing union labor, I have contacted Chicagoland labor unions to request Evanston residents for employment in compliance with LEP on this project, and have nonetheless been unable to comply.

I have read The City of Evanston, Local Employment Program (LEP) requirements as set forth in City Code Section 1-17-1(C): Local Employment Program. I understand and will comply with the LEP requirements for this project with respect to the job and/or any waiver, as applicable. **I UNDERSTAND THAT IF MY APPLICATION IS NOT COMPLETE, MY BID MUST BE REJECTED.**

SIGNED:

|                             |                        |      |
|-----------------------------|------------------------|------|
| Signature                   | Printed Name and Title | Date |
| On behalf of Company: _____ |                        |      |

## **EXHIBIT D**

### **City of Evanston M/W/D/EBE Policy**

A City of Evanston goal is to provide contracting and sub-contracting opportunities to Minority Business Enterprises, Women Business Enterprises, Disadvantaged Business Enterprises, and Evanston Business Enterprises. The goal of the Minority, Women, Disadvantaged, and Evanston Business Enterprise Program (M/W/D/EBE) is to assist such businesses with opportunities to grow. To assist such growth, the City's goal is to have general contractors utilize M/W/D/EBEs to perform no less than 25% of the awarded contract.

Firms bidding on projects with the City must work to meet the 25% goal or request a waiver from participation. It is advised that bidders place advertisements requesting sub-contractors and that they email or contact individual firms that would be appropriate to partner in response to the project. For samples of possible advertisements, see the City of Evanston's Business Diversity Section <http://www.cityofevanston.org/business/business-diversity/> ([Sample Advertisement](#)).

If a bidder is unable to meet the required M/W/D/EBE goal, the Bidder must seek a waiver or modification of the goal on the attached forms. Bidder must include:

1. A narrative describing the Bidder's efforts to secure M/W/D/EBE participation prior to the bid opening.
2. Documentation of each of the assist agencies that were contacted, the date and individual who was contacted, and the result of the conversation (see form)
3. A letter attesting to instances where the bidder has not received inquiries/proposals from qualified M/W/D/EBEs
4. Names of owners, addresses, telephone numbers, date and time and method of contact of qualified M/W/D/EBE who submitted a proposal but was not found acceptable.
5. Names of owners, addresses, telephone numbers, date and time of contact of at least 15 qualified M/W/D/EBEs the bidder solicited for proposals for work directly related to the Bid prior to the bid opening (copies must be attached).

If a bidder is selected with a Sub-contractor listed to meet the M/W/D/EBE goal, a "monthly utilization report" will be due to the City prior to each payment being issued to the Contractor. This report will include documentation of the name of the firm hired, the type of work that firm performed, etc. Should the M/W/D/EBE not be paid according to the schedule proposed in this document, the City reserves the right to cancel the contract. Examples of this monthly form can be found on the City's website: <http://www.cityofevanston.org/business/business-diversity/> ([MWDEBE Monthly Utilization Report](#)).

**EXHIBIT E**

**M/W/D/EBE PARTICIPATION COMPLIANCE FORM**

I do hereby certify that,

\_\_\_\_\_ (Name of firm) intends to participate as a Subcontractor or General Contractor on the project referenced above.

This firm is a (check only one):

- \_\_\_\_\_ Minority Business Enterprise (MBE), a firm that is at least 51% managed and controlled by a minority, certified by a certifying agency within Illinois.
- \_\_\_\_\_ Women's Business Enterprise (WBE), a firm that is at least 51% managed and controlled by a woman, certified by a certifying agency within Illinois.
- \_\_\_\_\_ Disadvantaged Business Enterprise (DBE), a firm that is at least 51% managed and controlled by a disadvantaged, certified by a certifying agency within Illinois.
- \_\_\_\_\_ Evanston Based Enterprise (EBE), a firm located in Evanston for a minimum of one year and which performs a "commercially useful function".

Total proposed price of response \$ \_\_\_\_\_

Amount to be performed by a M/W/D/EBE \$ \_\_\_\_\_

Percentage of work to be performed by a M/W/D/EBE \_\_\_\_\_ %

Information on the M/W/D/EBE Utilized:

Name \_\_\_\_\_

Address \_\_\_\_\_

Phone Number \_\_\_\_\_

Signature of firm attesting to participation \_\_\_\_\_

Title and Date \_\_\_\_\_

Type of work to be performed \_\_\_\_\_

Please attach:

1. Proper certification documentation if applying as an M/W/D/EBE and check the appropriate box below. This M/W/D/EBE will be applying with documentation from:

- |                                                |                                                                        |
|------------------------------------------------|------------------------------------------------------------------------|
| <input type="checkbox"/> Cook County           | <input type="checkbox"/> State Certification                           |
| <input type="checkbox"/> Federal Certification | <input type="checkbox"/> Women's Business Enterprise National Council  |
| <input type="checkbox"/> City of Chicago       | <input type="checkbox"/> Chicago Minority Supplier Development Council |

2. Attach a business license if applying as an EBE

**EXHIBIT E**

**M/W/D/EBE UTILIZATION SUMMARY REPORT**

The following Schedule accurately reflects the value of each MBE/WBE/DBE/EBE sub-agreement, the amounts of money paid to each to date, and this Pay Request. The total proposed price for the submitted response is \_\_\_\_\_.

| <b>MBE/WBE/DBE/EBE<br/>FIRM NAME</b> | <b>FIRM TYPE<br/>(MBE/WBE/<br/>DBE/EBE)</b> | <b>SERVICES<br/>PERFORMED</b> | <b>AMOUNT OF<br/>SUB-<br/>CONTRACT</b> | <b>PERCENT OF<br/>TOTAL<br/>CONTRACT<br/>AMOUNT</b> |
|--------------------------------------|---------------------------------------------|-------------------------------|----------------------------------------|-----------------------------------------------------|
|                                      |                                             |                               | \$                                     |                                                     |
|                                      |                                             |                               | \$                                     |                                                     |
|                                      |                                             |                               | \$                                     |                                                     |
|                                      |                                             |                               | \$                                     |                                                     |
|                                      |                                             |                               | \$                                     |                                                     |
|                                      |                                             |                               | \$                                     |                                                     |
|                                      |                                             |                               | \$                                     |                                                     |
|                                      |                                             |                               | \$                                     |                                                     |
|                                      |                                             |                               | \$                                     |                                                     |
|                                      |                                             |                               | \$                                     |                                                     |
|                                      |                                             |                               | \$                                     |                                                     |
|                                      |                                             |                               | \$                                     |                                                     |
|                                      |                                             |                               | \$                                     |                                                     |
|                                      |                                             |                               | \$                                     |                                                     |
|                                      |                                             |                               | \$                                     |                                                     |
|                                      |                                             |                               | \$                                     |                                                     |
|                                      |                                             |                               | \$                                     |                                                     |
|                                      |                                             |                               | \$                                     |                                                     |
|                                      |                                             |                               | \$                                     |                                                     |
| <b>TOTAL</b>                         |                                             |                               | \$                                     |                                                     |

**EXHIBIT F**

**M/W/D/EBE PARTICIPATION WAIVER REQUEST**

I am \_\_\_\_\_ of \_\_\_\_\_, and I have the authority to  
(Title) (Name of Firm)

execute this certification on behalf of the firm. I \_\_\_\_\_ do  
(Name)

hereby certify that this firm seeks to waive all or part of this M/W/D/EBE participation goal for the following reason(s):

**(CHECK ALL THAT APPLY. SPECIFIC SUPPORTING DOCUMENTATION MUST BE ATTACHED.)**

\_\_\_\_\_ 1. No M/W/D/EBEs responded to our invitation to bid.

\_\_\_\_\_ 2. An insufficient number of firms responded to our invitation to bid.

**For #1 & 2, please provide a narrative describing the outreach efforts from your firm and proof of contacting at least 15 qualified M/W/D/EBEs prior to the bid opening. Also, please attach the accompanying form with notes regarding contacting the Assist Agencies.**

\_\_\_\_\_ 3. No sub-contracting opportunities exist.

**Please attach a written explanation of why sub-contracting is not feasible. Please provide details supporting your request.**

\_\_\_\_\_ 4. M/W/D/EBE participation is impracticable.

**Please attach a written explanation of why M/W/D/EBE participation is impracticable. Please provide details supporting your request.**

Therefore, we request to waive \_\_\_\_\_ of the 25% utilization goal for a revised goal of \_\_\_\_\_%.

Signature: \_\_\_\_\_  
(Signature)

Date: \_\_\_\_\_

## EXHIBIT G

### Construction Contractors' Assistance Organizations (“Assist Agencies”) Form

| AGENCY                                                                                                                                                                                                                                                             | DATE CONTACTED | CONTACT PERSON | RESULT OF CONVERSATION |
|--------------------------------------------------------------------------------------------------------------------------------------------------------------------------------------------------------------------------------------------------------------------|----------------|----------------|------------------------|
| <b>Association of Asian Construction Enterprises (AACE)</b><br>5500 Touhy Ave., Unit K<br>Skokie, IL. 60077<br>Phone: 847-5259693<br>Perry Nakachii, President                                                                                                     |                |                |                        |
| <b>Black Contractors United (BCU)</b><br>400 W. 76th Street<br>Chicago, IL 60620<br>Phone: 773-483-4000; Fax: 773-483-4150<br>Email: <a href="mailto:bcunewera@ameritech.net">bcunewera@ameritech.net</a>                                                          |                |                |                        |
| <b>Chicago Minority Business Development Council</b><br>105 West Adams Street<br>Chicago, Illinois 60603<br>Phone: 312-755-8880; Fax: 312-755-8890<br>Email: <a href="mailto:info@chicagomsdc.org">info@chicagomsdc.org</a><br>Shelia Hill, President              |                |                |                        |
| <b>Evanston Minority Business Consortium, Inc.</b><br>P.O. Box 5683<br>Evanston, Illinois 60204<br>Phone: 847-492-0177<br>Email: <a href="mailto:embcinc@aol.com">embcinc@aol.com</a>                                                                              |                |                |                        |
| <b>Federation of Women Contractors</b><br>5650 S. Archer Avenue<br>Chicago, Illinois 60638<br>Phone: 312-360-1122; Fax: 312-360-0239<br>Email: <a href="mailto:FWCChicago@aol.com">FWCChicago@aol.com</a><br>Contact Person: Beth Doria<br>Maureen Jung, President |                |                |                        |
| <b>Hispanic American Construction Industry (HACIA)</b><br>901 W. Jackson, Suite 205<br>Chicago, IL 60607<br>Phone: 312-666-5910; Fax: 312-666-5692<br>Email: <a href="mailto:info@haciaworks.org">info@haciaworks.org</a>                                          |                |                |                        |
| <b>Women’s Business Development Ctr.</b><br>8 S. Michigan Ave, Suite 400<br>Chicago, Illinois 60603<br>Phone: 312-853-3477 X220;<br>Fax: 312-853-0145<br>Email: <a href="mailto:wbdc@wbdc.org">wbdc@wbdc.org</a><br>Carol Dougal, Director                         |                |                |                        |

**PLEASE NOTE:** Use of the Construction Contractor’s Assistance Organization (Assist Agencies) Form and agencies is for use as a resource only. The agencies and or vendors listed are not referrals or recommendations by the City of Evanston.



**EXHIBIT I**

**DISCLOSURE OF OWNERSHIP INTERESTS**

City of Evanston Ordinance 15-0-78 requires all persons (APPLICANT) seeking to do business with the City to provide the following information with their bid. Every question must be answered. If the question is not applicable, answer with "NA".

APPLICANT NAME: \_\_\_\_\_

APPLICANT ADDRESS: \_\_\_\_\_

TELEPHONE NUMBER: \_\_\_\_\_

FAX NUMBER: \_\_\_\_\_

APPLICANT is (**Check One**)

1. Corporation ( ) 2. Partnership ( ) 3. Sole Owner ( ) 4. Association ( )

5. Other ( ) \_\_\_\_\_

Please answer the following questions on a separate attached sheet if necessary.

**SECTION I - CORPORATION**

1a. Names and addresses of all Officers and Directors of the Corporation.

\_\_\_\_\_  
\_\_\_\_\_  
\_\_\_\_\_

1b. (Answer only if corporation has 33 or more shareholders.) Names and addresses of all those shareholders owning shares equal to or in excess of 3% of the proportionate ownership interest and the percentage of shareholder interest. (Note: Corporations which submit S.E.C. form 10K may substitute that statement for the material required herein.)

\_\_\_\_\_  
\_\_\_\_\_  
\_\_\_\_\_

1c. (Answer only if the corporation has fewer than 33 shareholders.) Names and addresses of all shareholders and the percentage of interest of each herein. (Note: Corporations which submit S.E.C. form 10K may substitute that statement for the material requested herein.)

---

---

---

**SECTION 2 - PARTNERSHIP/ASSOCIATION/JOINT VENTURE**

2a. The name, address, and percentage of interest of each partner whose interests therein, whether limited or general is equal to or in excess of 3%.

---

---

---

2b. Associations: The name and address of all officers, directors, and other members with 3% or greater interest.

---

---

---

**SECTION 3 - TRUSTS**

3a. Trust number and institution.

---

3b. Name and address of trustee or estate administrator.

---

---

---

3c. Trust or estate beneficiaries: Name, address, and percentage of interest in total entity.

---

---

---

**SECTION 4 - ALL APPLICANTS - ADDITIONAL DISCLOSURE**

4a. Specify which, if any, interests disclosed in Sections 1, 2, or 3 are being held by an agent or nominee and give the name and address of the principal.

---

---

---

4b. If any interest named in Section 1, 2, or 3 is being held by a "holding" corporation or other "holding" entity not an individual, state the names and addresses of all parties holding more than a 3% interest in that "holding" corporation or entity as required in 1(a), 1(b), 1(c), 2(a), and 2(b).

---

---

---

4c. If "constructive control" of any interest named in Sections 1, 2, 3, or 4 is held by another party, give the name and address of the party with constructive control. ("Constructive control" refers to control established through voting trusts, proxies, or special terms of venture of partnership agreements.)

---

---

---

I have not withheld disclosure of any interest known to me. Information provided is accurate and current.

\_\_\_\_\_   
Date

\_\_\_\_\_   
Signature of Person Preparing Statement

\_\_\_\_\_   
Title

ATTEST: \_\_\_\_\_   
Notary Public

(Notary Seal)

Commission Expires: \_\_\_\_\_

**EXHIBIT J**

**ADDITIONAL INFORMATION SHEET**

Bid/Proposal Name: \_\_\_\_\_

Bid/Proposal Number #: \_\_\_\_\_

Company Name: \_\_\_\_\_

Contact Name: \_\_\_\_\_

Address: \_\_\_\_\_

City, State, Zip: \_\_\_\_\_

Telephone/FAX: # \_\_\_\_\_

E-mail: \_\_\_\_\_

**Comments:** \_\_\_\_\_

\_\_\_\_\_

\_\_\_\_\_

\_\_\_\_\_

\_\_\_\_\_

\_\_\_\_\_

\_\_\_\_\_

**EXHIBIT K**

**CERTIFICATE OF COMPLIANCE  
WITH PREVAILING WAGE RATE ACT**

The undersigned, upon being first duly sworn, hereby certifies to the City of Evanston, Cook, County, Illinois, that all work under this contract shall comply with the Prevailing Wage Rate Act of the State of Illinois, 820 ILCS 130 *et seq*, and as amended by Public Acts 86-799 and 86-693 and our current city ordinance, with rates to be paid in effect at time work is performed. Contractors shall submit monthly certified payroll records to the city.

Name of Contractor: \_\_\_\_\_

By: \_\_\_\_\_

By: State of \_\_\_\_\_, County of \_\_\_\_\_

Subscribed and sworn to before me this \_\_\_\_\_ day  
of \_\_\_\_\_, \_\_\_\_\_.

Notary Public

**EXHIBIT L**

**MAJOR SUB-CONTRACTORS LISTING**

The following Tabulation of Major Sub-contractors shall be attached and made a condition of the Bid. The Bidder expressly understands and agrees to the following provisions:

- A. If awarded a Contract as a result of this Bid, the major sub-contractors used in the prosecution of the work will be those listed below.
- B. The following list includes all sub-contractors who will perform work representing 5% (five percent) or more of the total Base Bid.
- C. The sub-contractors listed below are financially responsible and are qualified to perform the work required.
- D. The sub-contractors listed below comply with the requirements of the Contract Documents.
- E. Any substitutions in the sub-contractors listed below shall be requested in writing by the Contractor and must be approved in writing by the Owner. All pertinent financial, performance, insurance and other applicable information shall be submitted with the request for substitutions(s). Owner shall respond to such requests within 14 calendar days following the submission of all necessary information to the full satisfaction of the Owner.

| <b><u>Category</u></b> | <b><u>Name of Sub-contractor</u></b> | <b><u>Address and Telephone</u></b> |
|------------------------|--------------------------------------|-------------------------------------|
|                        |                                      |                                     |
|                        |                                      |                                     |
|                        |                                      |                                     |
|                        |                                      |                                     |
|                        |                                      |                                     |
|                        |                                      |                                     |
|                        |                                      |                                     |
|                        |                                      |                                     |
|                        |                                      |                                     |
|                        |                                      |                                     |

(Attach additional sheets as required)

**END OF SECTION**

**EXHIBIT M**

**CONFLICT OF INTEREST**

\_\_\_\_\_, hereby certifies that it has conducted an investigation into whether an actual or potential conflict of interest exists between the Bidder, its owners and employees and any official or employee of the City of Evanston.

Bidder further certifies that it has disclosed any such actual or potential conflict of interest and acknowledges if Bidder/proposer has not disclosed any actual or potential conflict of interest, the City of Evanston may disqualify the bid/proposal.

\_\_\_\_\_  
(Name of Bidder/proposer if the Bidder/proposer is an Individual)  
(Name of Partner if the Bidder/proposer is a Partnership)  
(Name of Officer if the Bidder/proposer is a Corporation)

The above statements must be subscribed and sworn to before a notary public.  
Subscribed and Sworn to this \_\_\_\_\_ day of \_\_\_\_\_, 20\_\_\_\_

\_\_\_\_\_  
Notary Public

(Notary Seal)

Commission Expires: \_\_\_\_\_

**EXHIBIT N**

**SIGNATURE FORM**

**THE SECTION BELOW MUST BE COMPLETED IN FULL AND SIGNED**

The undersigned hereby certifies that they have read and understand the contents of this solicitation and attached service agreements and agree to furnish at the prices shown any or all of the items above, subject to all instructions, conditions, specifications, and attachments hereto. Failure to have read all the provisions of this solicitation shall not be cause to alter any resulting contract or to accept any request for additional compensation. By signing this document, the proposer hereby certifies that they are not barred from bidding on this contract as a result of bid rigging, bid rotating, or any similar offense (720 ILCS 5/33 E-3, E-4).

Authorized Signature: \_\_\_\_\_

Company Name: \_\_\_\_\_

Typed/Printed Name: \_\_\_\_\_

Date: \_\_\_\_\_

Title: \_\_\_\_\_

Telephone Number: \_\_\_\_\_

E-mail \_\_\_\_\_

Fax Number: \_\_\_\_\_



**EXHIBIT O**

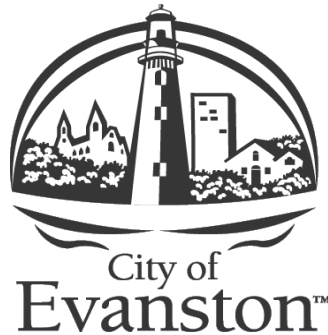

**CONTRACTOR SERVICES AGREEMENT**

The parties referenced herein desire to enter into an agreement for professional services for

**Levy Center Kitchen Remodel**

**(BID #26-29)**

THIS AGREEMENT (hereinafter referred to as the “Agreement”) is entered into between the City of Evanston, an Illinois municipal corporation with offices located at 909 Davis Street, Evanston Illinois 60201 (hereinafter referred to as the “City”), and *[Insert Contractor name here]*, with offices located at *[Insert Contractor address here]*, (hereinafter referred to as the “Contractor”). Compensation (the “Compensation”) for all basic services provided by the Contractor pursuant to the terms of this Agreement shall not exceed *[\$[Insert fee here]*.

*Revision March 2020*

**TABLE OF CONTENTS**

|    |                                                                             |    |
|----|-----------------------------------------------------------------------------|----|
| 1  | Services and Duties of the Contractor .....                                 | 4  |
| 2  | Standard Certifications.....                                                | 7  |
| 3  | Additional Services/Change Orders.....                                      | 10 |
| 4  | Bonds .....                                                                 | 12 |
| 5  | Liquidated Damages in the Event Contractor Fails to Complete the Work ..... | 13 |
| 6  | The City’s Responsibilities .....                                           | 13 |
| 7  | Period of Service.....                                                      | 13 |
| 8  | Payment for Services and Reimbursements.....                                | 13 |
| 9  | Notice and Cure/Termination .....                                           | 15 |
| 10 | Insurance .....                                                             | 16 |
| 11 | Indemnification .....                                                       | 17 |
| 12 | Drawings and Documents .....                                                | 18 |
| 13 | Successors and Assigns.....                                                 | 19 |
| 14 | Force Majeure .....                                                         | 19 |
| 15 | Amendments and Modifications .....                                          | 20 |
| 16 | Standard of Care & Warranty .....                                           | 20 |
| 17 | Savings Clause .....                                                        | 21 |
| 18 | Non-Waiver of Rights.....                                                   | 21 |
| 19 | Entire Agreement .....                                                      | 21 |
| 20 | Governing Law .....                                                         | 22 |
| 21 | Ownership of Contract Documents.....                                        | 22 |
| 22 | Notice .....                                                                | 22 |
| 23 | Severability .....                                                          | 22 |
| 24 | Execution of Agreement .....                                                | 22 |
| 25 | Counterparts .....                                                          | 23 |
| 26 | Authorizations.....                                                         | 23 |
| 27 | Time of Essence .....                                                       | 23 |

## RECITALS

WHEREAS, the City intends to retain the services of a qualified and experienced contractor for the following:

*[Insert whatever project specific background and language is appropriate]*

WHEREAS, this Agreement shall include the following documents which are attached hereto:

- a) City of Evanston Bid \_\_\_\_\_, attached as Exhibit A.
- b) Contractor's response to Bid \_\_\_\_\_, attached as Exhibit B.
- c) Any sub-contractor sub-contracts related to this Agreement, attached as Exhibit C.
- d) Project Fee Schedule and hourly rates, attached as Exhibit D *(if appropriate)*.

NOW, THEREFORE, in consideration of the mutual covenants hereinafter set forth, the parties agree as follows:

### 1 Services and Duties of the Contractor

1.1 The Contractor shall perform professional services and provide equipment (the "Work") in accordance with Exhibits A, B, C and D. The Contractor retains the right to control the manner of performance of the services provided for in this Agreement and is an independent contractor and not agent or an employee of the City. All employees and sub-contractors of the Contractor shall likewise not be considered to be employees of the City. Contractor is solely responsible for the means and methods of all work performed under the terms of this Agreement for this Project ("the Project"). Contractor is an independent Contractor and is solely responsible for all taxes, withholdings, and other statutory or contractual obligations of any sort, including but not limited to, Worker's Compensation Insurance. Nothing in this Agreement accords any third-party beneficiary rights whatsoever to any non-party to this Agreement that any non-party may seek to enforce. Contractor acknowledges and agrees that should Contractor or its sub-contractors provide false information, or fail to be or remain in compliance with this Agreement; the City may void this Agreement.

1.2 The Contractor warrants and states that it has read the Contract Documents, and agrees to be bound thereby, including all performance guarantees as respects Contractor's work and all indemnity and insurance requirements. Contractor further affirms that it has visited the Project site and has become familiar with all special conditions, if any, at the Project site. Contractor shall perform the Work and its obligations under this Agreement in accordance with and subject to the Contract Documents to the full extent that each such provision is applicable to the Work. Contractor shall take necessary precautions to properly protect the Work of others, if any, from damage caused by operations under this Agreement. In addition, Contractor shall protect the work during normal and adverse weather conditions until the Project is complete and accepted by the City, or until the Contractor has fully completed its work under this Agreement. Contractor's obligations include, but are not limited to, placing and adequately maintaining at or about all locations of Project work,

sufficient guards, barricades, lights, and enclosures to protect the Work.

1.3 The Contractor shall not have any public or private interest and shall not acquire directly or indirectly any such interest which conflicts in any manner with the performance of its services under this Agreement.

1.4 The Contractor shall designate, in writing, a person to act as its Project Manager for the work to be performed under this Agreement. Such person shall have complete authority to transmit instructions, receive information, interpret and define the Contractor's policies and decisions with respect to the work covered by this Agreement.

1.5 The Contractor shall employ only persons duly licensed by the State of Illinois to perform the professional services required under this Agreement for which applicable Illinois law requires a license, subject to prior approval of the City. The Contractor shall employ only well qualified persons to perform any of the remaining services required under this Agreement, also subject to prior approval of the City. The City reserves the right to require replacement of Contractor, sub-contractor, or supplier personnel for any reason. Contractor will replace the unacceptable personnel at no charge to the City. For all solicitations or advertisements placed by or on behalf of Contractor for employees for this Project it will state that the Contractor is an Equal Opportunity Employer.

1.6 Pursuant to the Illinois Freedom of Information Act, 5 ILCS 140/7(2), records in the possession of others whom the City has contracted with to perform a governmental function are covered by the Act and subject to disclosure within limited statutory timeframes (five (5) working days with a possible five (5) working day extension). Upon notification from the City that it has received a Freedom of Information Act request that calls for records within the Contractor's control, the Contractor shall promptly provide all requested records to the City so that the City may comply with the request within the required timeframe. The City and the Contractor shall cooperate to determine what records are subject to such a request and whether or not any exemption to the disclosure of such records, or part thereof, is applicable. Contractor shall indemnify and defend the City from and against all claims arising from the City's exceptions to disclosing certain records which Contractor may designate as proprietary or confidential. Compliance by the City with an opinion or a directive from the Illinois Public Access Counselor or the Attorney General under FOIA, or with a decision or order of Court with jurisdiction over the City, shall not be a violation of this Section.

1.7 The Contractor shall obtain prior approval from the City prior to sub-contracting with any entity or person to perform any of the work required under this Agreement. The Contractor may, upon request of the City, submit to the City a draft sub-contractor agreement for City review and approval prior to the execution of such an agreement. Any previously entered into sub-contractor agreement(s) are attached as Exhibit C. If the Contractor sub-contracts any of the services to be performed under this Agreement, the sub-contractor agreement shall provide that the services to be performed under any such agreement shall not be sublet, sold, transferred, assigned or otherwise disposed of to another entity or person without the City's prior written consent. The Contractor shall be responsible for the accuracy and quality of any sub-contractor's work.

1.8 The Contractor shall cooperate fully with the City, other City contractors, other municipalities and local government officials, public utility companies, and others, as may be directed by the City. This shall include attendance at meetings, discussions and hearings as requested by the City. This cooperation shall extend to any investigation, hearings or meetings convened or instituted by OSHA relative to this Project, as necessary. Contractor shall cooperate with the City in scheduling and performing its Work to avoid conflict, delay in or interference with the work of others, if any, at the Project.

1.9 The Contractor acknowledges that it shall enforce and comply with all applicable Occupational Safety and Health Administration standards (OSHA) for this Project in effect as of the date of the execution of this Agreement, or as otherwise promulgated by OSHA in the future taking effect during the pendency of this Project. Contractor shall enforce all such standards and ensure compliance thereto as to its own agents and employees, and as to the agents and employees of any sub-contractor throughout the course of this Project. Contractor is solely responsible for enforcing and complying with all applicable safety standards and requirements on this Project, and is solely responsible for correcting any practices or procedures which do not comply with the applicable safety standards and requirements for this Project. Any Project specific safety requirements applicable to this Project must be followed by Contractor and any sub-contractor(s) on the Project. Additionally, all such safety requirements shall be made a part of any sub-contractor agreement.

1.10 The Contractor shall submit to the City a progress report each month this Agreement is in effect. The report shall include the following items:

- a) A summary of the Contractor's project activities, and any sub-contractor project activities that have taken place during the invoice period;
- b) A summary of the Contractor's project activities and any sub-contractor project activities, that shall take place during the next invoice period;
- c) A list of outstanding items due to or from the City; and
- d) A status of the Project schedule.

1.11 The Contractor shall perform the work required under this Agreement pursuant to high quality industry standards expected by the City. The Contractor shall apply for and receive all appropriate permits before performing any work in the City. The Contractor shall also provide the appropriate permit drawings for Building Permits to be issued for the Project, if said permits are obligated by the Project. The City will assist the Contractor with obtaining the appropriate building and right-of-way permits.

1.12 The Contractor shall provide drawings of record, in the following 3 electronic formats for all locations where equipment has been installed and/or work has been performed. The electronic formats required by this Section 1.12 are Auto Cad Version 2025, ArcView and PDF.

1.13 Contractor recognizes that proper cleanup and removal of construction debris is an important safety consideration. The Contractor shall be solely responsible for daily construction site/area cleanup and removal of all construction debris in accordance with City-approved disposal practices. Contractor shall be solely responsible for identifying and removing at its expense all

hazardous material and waste which it uses and generates.

1.14 To the extent that there is any conflict between a provision specified in this Agreement, with a provision specified in any of the other Contract Documents, as defined in Section 1.15, this Agreement shall control. The City and the Contractor may amend this Section 1.14 as provided by Section 15 herein.

The Contractor acknowledges and agrees that the City has no retained control over any of the Work done pursuant to this Agreement, and that the City is expressly exempt from the retained control exception as defined in the Restatement of Torts, Second, Section 414. This provision shall survive completion, expiration, or termination of this Agreement.

1.15 The Contract Documents for this Project consist of:

- a) This Agreement;
- b) The City's RFP/RFQ, and the plans, specifications, general conditions, drawings addenda, and modifications thereto;
- c) The Contractor's response to the RFP/RFQ/Bid;
- d) Other exhibits and schedules, if any, listed in this Agreement;
- e) Amendments or Other Contract Documents, if any; and
- f) Amendments/Modifications to this Agreement issued after execution thereof.

1.16 As a condition of receiving payment, Contractor must (i) be in compliance with the Agreement, (ii) pay its employees prevailing wages when required by law (Examples of prevailing wage categories include public works, printing, janitorial, window washing, building and grounds services, site technician services, natural resource services, security guard and food services). Contractor is responsible for contacting the Illinois Dept. of Labor 217-782-6206; <http://www.illinois.gov/idol/Laws-Rules/CONMED/Pages/Rates.aspx> to ensure compliance with prevailing wage requirements), (iii) pay its suppliers and sub-contractors according to the terms of their respective contracts, and (iv) provide lien waivers to the City upon request.

## 2 Standard Certifications

Contractor acknowledges and agrees that compliance with this section and each subsection for the term of the Agreement is a material requirement and condition of this Agreement. By executing this Agreement, Contractor certifies compliance with this section and each subsection and is under a continuing obligation to remain in compliance and report any non-compliance.

This section, and each subsection, applies to sub-contractors used on this Agreement. Contractor shall include these Standard Certifications in any sub-contract used in the performance of the Agreement.

If this Agreement extends over multiple fiscal years, Contractor and its sub-contractors shall confirm compliance with this section in the manner and format determined by the City by the date specified by the City and in no event later than January 1 of each year that this Agreement remains in effect.

If the City determines that any certification in this section is not applicable to this Agreement, it may be stricken, subject to sole approval by the City, without affecting the remaining subsections.

2.1 As part of each certification, Contractor acknowledges and agrees that should Contractor or its sub-contractors provide false information, or fail to be or remain in compliance with the Standard Certification requirements, one or more of the following sanctions will apply:

- the Agreement may be void by operation of law,
- the City may void the Agreement, and
- Contractor and its sub-contractors may be subject to one or more of the following: suspension, debarment, denial of payment, civil fine, or criminal penalty.

2.2 By signing this Agreement, the Contractor certifies that it has not been barred from being awarded a contract with a unit of State or local Government as a result of bid rigging or bid rotating or similar offense, nor has it made any admission of guilt of such conduct that is a matter of public record. (720 ILCS 5/33 E-3, E-4).

2.3 In the event of the Contractor's noncompliance with any provision of Section 1-12-5 of the Evanston City Code, the Illinois Human Rights Act or any other applicable law, the Consultant may be declared non-responsible and therefore ineligible for future contracts or sub-contracts with the City, and the contract may be cancelled or voided in whole or in part, and such other sanctions or penalties may be imposed or remedies invoked as provided by statute or regulation.

2.4 During the term of this Agreement, the Contractor agrees as follows:

- a) That it will not discriminate against any employee or applicant for employment because of race, color, religion, sex, sexual orientation, marital status, national origin or ancestry, or age or physical or mental disabilities that do not impair ability to work, and further that it will examine all job classifications to determine if minority persons or women are underutilized and will take appropriate affirmative action to rectify any such underutilization. Consultant shall comply with all requirements of City of Evanston Code Section 1-12-5.
- b) That, in all solicitations or advertisements for employees placed by it on its behalf, it will state that all applicants will be afforded equal opportunity without discrimination because of race, color, religion, sex, sexual orientation, marital status, national origin, ancestry, or disability.

2.5 The Contractor certifies pursuant to the Illinois Human Rights Act (775 ILCS 5/2105 *et. seq.*), that it has a written sexual harassment policy that includes, at a minimum, the following information:

- a) The illegality of sexual harassment;

- b) The definition of sexual harassment under State law;
- c) A description of sexual harassment utilizing examples;
- d) The Contractor's internal complaint process including penalties;
- e) Legal recourse, investigation and complaint process available through the Illinois Department of Human Rights and the Human Rights Commission, and directions on how to contact both; and
- f) Protection against retaliation as provided to the Department of Human Rights.

2.6 In accordance with the Steel Products Procurement Act (30 ILCS 565), Contractor certifies steel products used or supplied in the performance of a contract for public works shall be manufactured or produced in the U.S. unless the City grants an exemption.

2.7 Contractor certifies that it is properly formed and existing legal entity and as applicable has obtained an assumed name certificate from the appropriate authority, or has registered to conduct business in Illinois and is in good standing with the Illinois Secretary of State.

2.8 If Contractor, or any officer, director, partner, or other managerial agent of Contractor, has been convicted of a felony under the Sarbanes-Oxley Act of 2002, or a Class 3 or Class 2 felony under the Illinois Securities Law of 1953, Contractor certifies at least five years have passed since the date of the conviction.

2.9 Contractor certifies that if more favorable terms are granted by Contractor to any similar governmental entity in any state in a contemporaneous agreement let under the same or similar financial terms and circumstances for comparable supplies or services, the more favorable terms will be applicable under this Agreement.

2.10 Contractor certifies that it is not delinquent in the payment of any fees, fines, damages, or debts to the City of Evanston.

2.11 The Contractor certifies that all Design Professionals performing the Work under this Agreement will ensure that the Project shall be designed in conformance with the Americans with Disabilities Act of 1990, 42 U.S.C. Section 12101, *et seq.*, and all regulations promulgated thereunder. Design Professional means any individual, sole proprietorship, firm, partnership, joint venture, corporation, professional corporation, or other entity that offers services under the Illinois Architecture Practice Act of 1989 (225 ILCS 305/), the Professional Engineering Practice Act of 1989 (225 ILCS 325/), the Structural Engineering Licensing Act of 1989 (225 ILCS 340/), or the Illinois Professional Land Surveyor Act of 1989 (225 ILCS 330/).

2.12 The Contractor shall comply with all federal, state and local laws, statutes, ordinances, rules, regulations, orders or other legal requirements now in force or which may be in force during the term of this Agreement. The Contractor shall comply with the Illinois Human Rights Act, 775 ILCS 5/1-101 *et. seq.*, Title VII of the Civil Rights Act of 1964, and the Illinois Prevailing Wage Act, 820 ILCS 130/0.01 *et. seq.*

### 3 Additional Services/Change Orders

3.1 If the representative of the City responsible for the Project verbally requests the Contractor to perform additional services, the Contractor shall confirm in writing that the services have been requested and that such services are additional services. Failure of the City to respond to the Contractor's confirmation of said services within thirty (30) calendar days of receipt of the notice shall be deemed a rejection of, and refusal to pay for the additional services. Contractor shall not perform any additional services until City has confirmed approval of said additional services in writing. If authorized in writing by the City, the Contractor shall furnish, or obtain from others, additional services of the following types, which shall be paid for by the City as set forth in Section 9 of this Agreement:

- a) Additional Services due to significant changes in scope of the Project or its design, including, but not limited to, changes in size, complexity or character of construction, or time delays for completion of work when such delays are beyond the control of the Contractor;
- b) Revisions of previously approved studies, reports, design documents, drawings or specifications;
- c) Preparation of detailed renderings, exhibits or scale models for the Project;
- d) Investigations involving detailed consideration of operations, maintenance and overhead expenses for the preparation of rate schedules, earnings and expense statements, feasibility studies, appraisals and valuations, detailed quantity surveys of material and labor, and material audits or inventories required for certification of force account construction performed by the City;
- e) Services not otherwise provided for in this Agreement.

3.2 The City may, upon written notice, and without invalidating this Agreement, require changes resulting in the revision or abandonment of work already performed by the Contractor, or require other elements of the work not originally contemplated and for which full compensation is not provided in any portion of this Agreement. Any additional services, abandonment of services which were authorized by the City, or changes in services directed by the City which result in the revision of the scope of services provided for in Exhibits A, B, C, and D that cause the total Compensation due Contractor under this Agreement to exceed \$25,000 or more, or increase or decrease the contract duration by more than 30 days are subject to approval by the Evanston City Council. These actions must be addressed either in a written Change Order or in a written amendment to this Agreement approved by both parties.

3.3 Contractor acknowledges and agrees that the Public Works Construction Change Order Act, 50 ILCS 525/1 et seq. shall apply to all Change Orders for the Project. It is expressly understood and agreed to by Contractor that it shall not be entitled to any damages or Compensation from the City on account of delay or suspension of all or any part of the Work. Contractor acknowledges that delays are inherent in construction projects and Contractor assessed that risk and fully included that risk assessment within its contract sum specified in its Response to the City Bid for this Project. The City shall not compensate Contractor for work that is more difficult than the contract sum specified in its Response would reflect. Delays to minor portions of the Work will not be eligible for extensions of time.

Delays to the Project caused by labor disputes or strikes involving trades not directly related to the Project, or involving trades not affecting the Project as a whole will not be eligible for an extension of time.

The City will not grant an extension of time for a delay by the Contractor's inability to obtain materials unless the Contractor first furnishes to the City documentary proof. The proof must be provided in a timely manner in accordance with the sequence of the Contractor's operations and accepted construction schedule.

In addition to any other changes requested by City (as described in Sections 3.1 and 3.2), the Company shall be entitled to request (and the City may grant) Change Orders with respect to:

- (a) The City-caused delays;
- (b) Change in Law;
- (c) Force Majeure Events.

The foregoing events shall entitle the Contractor to a change in the Compensation for this Project, if the Contractor demonstrates that it will unavoidably incur reasonable costs as a result thereof and the Contractor provides reasonable and detailed documentary support with respect to any such price impact.

The parties agree to reasonably confer regarding any such disputes with respect to the issuance of a Change Order.

Any payment for compensable delay will only be based upon actual costs excluding, without limitation, what damages, if any, the Contractor may have reasonably avoided. The Contractor understands that this is the sole basis for recovering delay damages and explicitly waives any right to calculate daily damages for office overhead, profit, or other purported loss.

All Contractor Change Orders authorized under this Section 3 shall be made in writing. In remitting a Change Order, the Contractor must first show in writing that:

- (a) The work was outside the scope of this Agreement,
- (b) The extra work was not made necessary due to any fault of Contractor;
- (c) The circumstances said to necessitate the change in performance were not reasonably foreseeable at the time the Agreement was signed;
- (d) The change is germane to the original Agreement; and
- (e) The Change Order is in the best interest of the City and authorized by law.

Any person who fails to first obtain the City's written authorization for a Change Order commits a Class 4 felony. The written determination and the written Change Order resulting from that determination shall be preserved in the contract's file which shall be open to the public for inspection.

**The City reserves all rights and causes of action, at law or equity, to seek redress against entities or persons who violate the requirements of this Section 3. By initialing below, Contractor hereby acknowledges that it is bound by this Section 3.**

**Contractor's Initials:** \_\_\_\_\_

3.4 The Contractor is required to include the City of Evanston as a reference whenever and wherever the Contractor provides references for similar projects for a period of one (1) year from the date of Final Acceptance by the City of the Work for this Project.

## 4 Bonds

4.1 Before the Scheduled Construction Commencement Date, the Contractor is required to furnish unconditional performance and payment bonds in the amount of 100% of the Compensation as security for the faithful performance and completion of all the Contractor's obligations under the Contract Documents and covering the payment of all materials used in the performance of this Agreement and for all labor and services performed under this Agreement. All Bonds shall be issued on a form acceptable to the City. The bonds must be for the entire term of the Agreement. Failure to provide these bonds shall constitute a breach of Contractor's obligations under this Agreement. Each surety providing the Bonds must have a Best's rating not less than A/X and be licensed in Illinois and shall be named in the current list of "Companies Holding Certificates of Authority as Acceptable Sureties on Federal Bonds and as Acceptable Reinsuring Companies" as published in Circular 570 as published in the Federal Register and available on the website of the U.S. Department of the Treasury, Financial Management Service, at [www.fms.treas.gov/c570/c570.html](http://www.fms.treas.gov/c570/c570.html). All Bonds signed by an agent must be accompanied by a certified copy of his or her authority to act. It shall be the duty of the Contractor to advise the surety or sureties of any Change Orders that result in an increase to the Compensation and to ensure that the amounts of the Bonds are updated to reflect and cover any such increases throughout the course of the Project. The cost of such Bonds shall be included within the Compensation.

4.2 If the surety behind any Bond furnished by the Contractor is declared bankrupt or becomes insolvent or its right to do business is terminated in the State or it ceases to meet any of the requirements of this Contract, the Contractor shall, within [5] five days thereafter, substitute another Bond of equivalent value and surety, both of which must be acceptable to the City. In addition, no further progress payments under the Agreement will be made by the City until the Contractor complies with the provisions of this Agreement. The Contractor shall furnish to the City proof of any required bonds and proof of required insurance as one of the conditions precedent to payment under the Agreement. Upon the request of any person or entity appearing to be a potential beneficiary of bonds covering payment or performance of obligations arising under the Contract, the Contractor shall promptly furnish a copy of the bonds or authorize a copy to be furnished. All surety Bonds provided for in this Section shall incorporate by reference this Agreement, and any language that may be in any such surety Bond which conflicts with the provisions of this Agreement that define the scope of the surety('s) duty(ies) shall be of no force and effect.

## 5 Liquidated Damages in the Event Contractor Fails to Complete the Work

5.1 The parties agree that failure of Contractor to timely complete the Work required by this Agreement constitutes a default. The parties agree that this default will result in damage and injury to City. The parties further agree, however, that actual damages incurred by City as result of such default is difficult if not impossible to ascertain with any degree of certainty or accuracy. Accordingly, the parties have negotiated and have agreed that for each calendar day after written notice is delivered to Contractor and Contractor fails to cure such default, that Contractor will pay City, as and for liquidated damages, and not as a penalty, a sum in the amount as specified in Section 108.09 of the IDOT Standard Specifications per calendar day. Contractor shall reimburse the City for all costs, expenses and fees (including, without limitation, attorneys' fees), if any, paid by the City in connection with such written demand by City. Contractor stipulates and agrees that the sums payable by Contractor under this Section are reasonable under the circumstances existing as of the execution of this Agreement. This Section 5.1 is not intended to limit any direct damages that may be recoverable by City related to the Contractor's failure to complete the Work in accordance with this Agreement. There shall be no early completion bonus if the Work is completed before the contract's deadlines. The City, at its option, may withhold liquidated damages from progress payments payable to Contractor before project completion.

## 6 The City's Responsibilities

6.1 The City may evaluate the Contractor's and any sub-contractor's performance (interim and final). Timeliness in meeting the Project schedule and the overall relationship with the Contractor are factors that will be considered in the Contractor's performance rating. An unfavorable performance rating may be a factor when future assignments are being considered.

6.2 The City makes no representation or warranty of any nature whatsoever as to the accuracy of information or documentation provided by the City to the Contractor which were generated or provided by third parties.

## 7 Period of Service

7.1 The Contractor shall commence work on the Project after supplying the City with the Contractor's performance and payment bonds and all required insurance documents before starting its Work on this Project. The City shall determine when the Contractor has completed the Work required pursuant to this Agreement, and shall determine the date of Final Acceptance. Contractor recognizes time is of the essence regarding its performance on this Project. Contractor shall continue to perform its obligations while any dispute concerning the Agreement is being resolved, unless otherwise directed by the City.

7.2 Each phase of the project shall be completed in accordance with the activities outlined in the City's Bid [REDACTED], Exhibit A.

## 8 Payment for Services and Reimbursements

8.1 Within the first five (5) business days of each month, the Contractor shall invoice the

City for Work completed during the previous month. The Contractor shall provide a detailed invoice that relates invoiced items to the Contractor's response to Bid [REDACTED] in both quantity and unit cost. Any discrepancies in the monthly invoice shall be promptly brought to the attention of the Contractor by the City Project Manager and efforts shall be made to promptly resolve said discrepancies between the City and Contractor. In the event the City and Contractor cannot resolve invoice discrepancies, items in dispute will be removed from the invoice and the City shall approve the remainder of the invoice. Payment will be made as soon as possible following the City Council meeting in which the item appeared on the bills list, and in accordance with all applicable laws and rules of the City of Evanston and the State of Illinois.

8.2 In the event of termination by the City of this Agreement pursuant to paragraph 9.1 after completion of any phase of the basic services, fees due the Contractor for services rendered through such phase shall constitute final payment for such services, and no further fees shall be due to the Contractor. In the event of such termination by the City during any phase of the basic services, the Contractor shall be paid for services rendered on the basis of the proportion of work completed on the phase to date of termination.

8.3 The City shall have the right to withhold payment to the Contractor due to the quality of a portion or all of the work performed hereunder which is not in accordance with the requirements of this Agreement, or which is unsatisfactory, or is due to the Contractor's failure or refusal to perform any of its obligations hereunder. Compensation in excess of the total contract amount specified in this Agreement will not be allowed unless justified in the City's sole judgment and authorized in advance as provided for in Section 3 of this Agreement. Compensation for improper performance by the Contractor is disallowed.

8.4 Upon completion of the Work performed by the Contractor, prior to the submission of a request for final payment, the City and Contractor shall perform a final acceptance test and review of the Work performed and/or equipment installed pursuant to the Agreement. A punch list of items outstanding will be jointly developed by the City and Contractor. In addition, the Contractor shall submit drawings of record for the Project for the City to approve. The Contractor shall promptly resolve all punch list items to the satisfaction of the City and shall transmit to the City in writing confirmation that all punch list items have been resolved. The City will review, and the Contractor shall modify, as necessary, any drawings of record to the satisfaction of the City. Punch list items and drawings of record must be approved by the City prior to the Contractor submitting its final invoice for payment.

8.5 The Contractor shall submit an Affidavit and a final waiver of its lien, and all final waivers of liens of any sub-contractors, suppliers, and sub-sub-contractors, if applicable, with its final invoice, stating that all obligations incurred in performance of the professional services have been paid in full. The Affidavit will also include a statement stating that the professional services were performed in compliance with the terms of the Agreement. The Affidavit and all final lien waivers shall be on a form acceptable to the City.

8.6 All Project invoices shall be sent to:

City of Evanston *[Applicable department]*  
909 Davis Street  
Evanston, Illinois 60201

with a copy to:

City of Evanston *[Anyone else as applicable]*  
909 Davis Street  
Evanston, Illinois 60201

## 9 Notice and Cure/Termination

9.1 In furtherance of Contractor's Work on this Project, the City and the Contractor agree that the following Notice and Cure provision in this Section 9.1 shall apply during the duration of Contractor's work on this Project, in addition to the reserved rights of the City enumerated in this Agreement as follows:

- 5.1 Liquidated Damages;
- 8.3 City's right to withhold payment;
- 16.2 Contractor's duty to revise and correct errors; and
- 16.3 Contractor's duty to respond to City's notice of errors and omissions.

The City may notify Contractor of its intent to terminate this Agreement within (7) seven calendar days of issuance by the City of written notice to Contractor's Project Manager regarding defects in the Project or in Contractor's Work. The City shall specify any such nonconforming Work or defects in the Project in its notice to Contractor under this Section 9.1. Contractor will have the opportunity to cure the non-conforming Work within (7) seven calendar days after receipt of the written notice issued by the City. All such curative work done shall be performed and completed to the City's satisfaction. Nothing in this Section 9.1 shall otherwise affect the City's right to exercise its rights in Section 9.2.

9.2 The City shall have the right to terminate this Agreement upon fifteen (15) days written notice for any reason. Mailing of such notice shall be equivalent to personal notice and shall be deemed to have been given at the time of receipt.

Payments made by the City pursuant to this Agreement are subject to sufficient appropriations made by the City of Evanston City Council. In the event of termination resulting from non-appropriation or insufficient appropriation by the City Council, the City's obligations hereunder shall cease and there shall be no penalty or further payment required.

9.3 Within thirty (30) days of termination of this Agreement, the Contractor shall turn over to the City any documents, drafts, and materials, including but not limited to, outstanding work product, data, studies, test results, source documents, AutoCAD Version 2025, ArcView, PDF, Word, Excel spreadsheets, technical specifications and calculations, and any other such items

specifically identified by the City related to the Work herein. Upon receipt of said items, the Contractor shall be paid for labor and expenses incurred to the date of termination as provided in Section 8.2. This Agreement is subject to termination by either party if either party is restrained by a state or federal court of competent jurisdiction from performing the provisions of this Agreement. Upon such termination, the liabilities of the parties to this Agreement shall cease, but they shall not be relieved of the duty to perform their obligations through the date of termination. No lien shall be filed by the Contractor in the event of a termination of this Agreement by the City.

9.4 If, because of death or any other occurrence, including, but not limited to, Contractor becoming insolvent, it becomes impossible for any principal or principals of the Contractor to render the services set forth in this Agreement, neither the Contractor, nor its surviving principals shall be relieved of their obligations to complete the professional services. However, in the event of such an occurrence, the City at its own option may terminate this Agreement if it is not furnished evidence that competent professional services can still be furnished as scheduled.

9.5 In the event of an emergency or threat to the life, safety, or welfare of the citizens of the City, the City shall have the right to terminate this Agreement without prior written notice.

## 10 Insurance

10.1 The Contractor shall, at its own expense, secure and maintain in effect throughout the duration of this contract, insurance against claims for injuries to persons or damages to property which may arise from or in connection with the performance of the Work hereunder by the Contractor, its agents, representatives, employees or sub-contractors. Contractor acknowledges and agrees that if it fails to comply with all requirements of this Section 10, the City may void the Agreement.

The Contractor must give to the City Certificates of Insurance identifying the City to be an Additional Insured for all Work done pursuant to this Agreement before City staff recommends award of the contract to City Council. Any limitations or modifications on the Certificate(s) of Insurance issued to the City in compliance with this Section that conflict with the provisions of this Section 10 shall have no force and effect.

After award of the Contract to Contractor (contracts over \$500,000 in value or if the project is deemed high risk) the Contractor **shall** give the City a certified copy (ies) of the insurance policy (ies) evidencing the amounts set forth in Section 10.2, and copies of the Additional Insured endorsement to such policy (ies) which name the City as an Additional Insured for all Work done pursuant to this Agreement before Contractor does any Work pursuant to this Agreement. Contractor's certificate of insurance shall contain a provision that the coverage afforded under the policy(s) will not be canceled or reduced without thirty (30) days prior written notice (hand delivered or registered mail) to the City. Contractor shall promptly forward new certificate(s) of insurance evidencing the coverage(s) required herein upon annual renewal of the subject policies.

The policies and the Additional Insured endorsement must be delivered to the City within two (2) weeks of the request. All insurance policies shall be written with insurance companies licensed or authorized to do business in the State of Illinois and having a rating of not less than A-

VII according to the A.M. Best Company. Should any of the insurance policies be canceled before the expiration date, the issuing company will mail thirty (30) days written notice to the City. The Contractor shall require and verify that all sub-contractors maintain insurance meeting all of the requirements stated herein.

Any deductibles or self-insured retentions must be declared to and approved by the City. At the option of the City, either the insurer shall reduce or eliminate such deductibles or self-insured retentions as respects the City, its officers, officials, employees and volunteers; or the Contractor shall provide a financial guarantee satisfactory to the City guaranteeing payment of losses and related investigations, claim administration and defense expenses.

10.2 Contractor shall carry and maintain at its own cost with such companies as are reasonably acceptable to City all necessary liability insurance (which shall include as a minimum the requirements set forth below) during the term of this Agreement, for damages caused or contributed to by Contractor, and insuring Contractor against claims which may arise out of or result from Contractor's performance or failure to perform the Services hereunder:

- a) Worker's compensation in statutory limits and employer's liability insurance in the amount of at least five hundred thousand dollars (\$500,000);
- b) Comprehensive general liability coverage which designates the City as an additional insured for not less than three million dollars (\$3,000,000) combined single limit for bodily injury, death and property damage, per occurrence;
- c) Comprehensive automobile liability insurance covering owned, non-owned, and leased vehicles for not less than one million dollars (\$1,000,000) combined single limit for bodily injury, death, or property damage, per occurrence; and

Contractor understands that the acceptance of Certificates of Insurance, policies, and any other documents by the City in no way releases the Contractor and its sub-contractors from the requirements set forth herein.

Contractor expressly agrees to waive its rights, benefits and entitlements under the "Other Insurance" clause of its commercial general liability insurance policy as respects the City. Contractor expressly agrees that its insurance coverage is required to be primary by this Agreement, that its insurance coverage shall be on a primary and non-contributory basis, and that it and its insurance carrier are estopped from denying such coverage is primary. In the event Contractor fails to purchase or procure insurance as required above, the parties expressly agree that Contractor shall be in default under this Agreement, and that the City may recover all losses, attorney's fees and costs expended in pursuing a remedy, or reimbursement, at law or in equity, against Contractor.

## 11 Indemnification

11.1 The Contractor shall defend, indemnify and hold harmless the City and its officers, elected and appointed officials, agents, and employees from any and all liability, losses, or damages as a result of claims, demands, suits, actions, or proceedings of any kind or nature, including but not limited to costs, and fees, including attorney's fees, judgments or settlements, resulting from or

arising out of any negligent or willful act or omission on the part of the Contractor or Contractor's sub-contractors, employees, agents or sub-contractors during the performance of this Agreement. Such indemnification shall not be limited by reason of the enumeration of any insurance coverage herein provided. This provision shall survive completion, expiration, or termination of this Agreement.

11.2 Nothing contained herein shall be construed as prohibiting the City, or its officers, agents, or employees, from defending through the selection and use of their own agents, attorneys, and experts, any claims, actions or suits brought against them. The Contractor shall be liable for the costs, fees, and expenses incurred in the defense of any such claims, actions, or suits. Nothing herein shall be construed as a limitation or waiver of defenses available to the City and employees and agents, including but not limited to the Illinois Local Governmental and Governmental Employees Tort Immunity Act, 745 ILCS 10/1-101 *et seq.*

At the City Corporation Counsel's option, Contractor must defend all suits brought upon all such Losses and must pay all costs and expenses incidental to them, but the City has the right, at its option, to participate, at its own cost, in the defense of any suit, without relieving Contractor of any of its obligations under this Agreement. Any settlement of any claim or suit related to this Project by Contractor must be made only with the prior written consent of the City Corporation Counsel, if the settlement requires any action on the part of the City.

To the extent permissible by law, Contractor waives any limits to the amount of its obligations to indemnify, defend, or contribute to any sums due under any Losses, including any claim by any employee of Contractor that may be subject to the Illinois Workers Compensation Act, 820 ILCS 305/1 *et seq.* or any other related law or judicial decision, including but not limited to, *Kotecki v. Cyclops Welding Corporation*, 146 Ill. 2d 155 (1991). The City, however, does not waive any limitations it may have on its liability under the Illinois Workers Compensation Act, the Illinois Pension Code or any other statute.

11.3 The Contractor shall be responsible for any losses and costs to repair or remedy work performed under this Agreement resulting from or arising out of any act or omission, neglect, or misconduct in the performance of its Work or its sub-contractors' work. Acceptance of the work by the City will not relieve the Contractor of the responsibility for subsequent correction of any such error, omissions and/or negligent acts or of its liability for loss or damage resulting therefrom.

11.4 All provisions of this Section 11 shall survive completion, expiration, or termination of this Agreement.

## 12 Drawings and Documents

12.1 Any drawings, survey data, reports, studies, specifications, estimates, maps, plans, computations, and other documents required to be prepared by the Contractor for the Project shall be considered Works for Hire and the sole property of the City.

12.2 The Contractor and its sub-contractor shall maintain for a minimum of three (3) years after the completion of this Agreement, or for three (3) years after the termination of this Agreement,

whichever comes later, adequate books, records and supporting documents to verify the amounts, recipients and uses of all disbursements of funds passing in conjunction with the Agreement. The Agreement and all books, records and supporting documents related to the Agreement shall be available for review and audit by the City and the federal funding entity, if applicable, and the Contractor agrees to cooperate fully with any audit conducted by the City and to provide full access to all materials. Failure to maintain the books, records and supporting documents required by this Subsection shall establish a presumption in favor of the City for recovery of any funds paid by the City under the Agreement for which adequate books, records, and supporting documentation are not available to support their purported disbursement.

### 13 Successors and Assigns

13.1 The City and the Contractor each bind themselves and their partners, successors, executors, administrators, and assigns to the other party of the Agreement and to the partners, successors, executors, administrators, and assigns of such other party in respect to all covenants of this Agreement. Neither the City nor the Contractor shall assign, sublet, or transfer its interest in this Agreement without the written consent of the other. Nothing herein shall be construed as creating any personal liability on the part of any officer or agent of any public body, which may be a party hereto, nor shall it be construed as giving any right or benefits hereunder to anyone other than the City and the Contractor.

### 14 Force Majeure

14.1 Whenever a period of time is provided for in this Agreement for the Contractor or the City to do or perform any act or obligation, neither party shall be liable for any delays or inability to perform if such delay is due to a cause beyond its control and without its fault or negligence including, without limitation:

- a) Acts of nature;
- b) Acts or failure to act on the part of any governmental authority other than the City or Contractor, including, but not limited to, enactment of laws, rules, regulations, codes or ordinances subsequent to the date of this Agreement;
- c) Acts of war;
- d) Acts of civil or military authority;
- e) Embargoes;
- f) Work stoppages, strikes, lockouts, or labor disputes;
- g) Public disorders, civil violence, or disobedience;
- h) Riots, blockades, sabotage, insurrection, or rebellion;
- i) Epidemics or pandemics;
- j) Terrorist acts;
- k) Fires or explosions;
- l) Nuclear accidents;
- m) Earthquakes, floods, hurricanes, tornadoes, or other similar calamities;
- n) Major environmental disturbances; or
- o) Vandalism.

If a delay is caused by any of the *force majeure* circumstances set forth above, the time

period shall be extended for only the actual amount of time said party is so delayed. Further, either party claiming a delay due to an event of *force majeure* shall give the other party written notice of such event within three (3) business days of its occurrence or it shall be deemed to be waived.

## 15 Amendments and Modifications

15.1 Except as otherwise provided herein, the nature and scope of Work specified in this Agreement may only be modified by a written Change Order, or a written amendment to this Agreement, approved by both parties. This Agreement may be modified or amended from time to time provided, however, that no such amendment or modifications shall be effective unless reduced to writing and duly authorized and signed by the authorized representatives of the parties.

## 16 Standard of Care & Warranty

16.1 The Contractor shall perform all of the provisions of this Agreement to the satisfaction of the City. The City shall base its determination of the Contractor's fulfillment of the scope of the work in accordance with generally accepted professional standards applicable to the Work for this Project. The Contractor shall perform all of the provisions of this Agreement with that degree of care and skill ordinarily exercised by members of the same profession currently practicing under similar conditions.

16.2 The Contractor shall be responsible for the accuracy of its professional services under this Agreement and shall promptly make revisions or corrections resulting from its errors, omissions, or negligent acts without additional compensation. The City's acceptance of any of the Contractor's professional services shall not relieve the Contractor of its responsibility to subsequently correct any such errors or omissions. If a Contractor has provided the City with specifications for this Project which are determined to be incorrect or which require revision during the solicitation process (including but not limited to Requests for Proposals, Requests for Qualifications, or bids), the Contractor shall make such corrections or revisions to the specifications at no cost to the City. Further, upon receipt of an invoice from the City, the Contractor shall promptly reimburse the City for the reasonable costs associated with the preparation and dissemination of said corrections or revisions to appropriate parties, including but not limited to preparation of the corrected or revised documents, and printing and distribution costs.

16.3 During the pendency of its Work on this Project, the Contractor shall respond to the City's notice of any errors or omissions within twenty-four (24) hours. The Contractor shall be required to promptly visit the Project site(s) if directed to by the City.

16.4 The Contractor shall comply with all federal, state, and local statutes, regulations, rules, ordinances, judicial decisions, and administrative rulings applicable to its performance under this Agreement.

16.5 Contractor guarantees and warrants to the City that:

- a) All materials and equipment furnished under this Agreement shall be of good quality

- b) and new, unless otherwise required or permitted by the Contract Documents;
- b) The Work of this Agreement shall be free from defects which are not inherent in the quality required; and
- c) The Work shall comply with the requirements set forth in the Contract Documents.

This warranty and guarantee shall be for a period of one (1) year from the date of completion and Final Acceptance of the Work by the City, or as otherwise provided in the Contract Documents.

If, within the one year warranty period, after the Contractor has received a final payment under this Agreement, any of the Work is found to be not be in accordance with the requirements of this Agreement, or where defects in materials or workmanship may appear, or be in need of repair, the Contractor shall correct non-conforming and/or defective work or materials promptly after receipt of written notice from the City. Contractor shall immediately at its own expense repair, replace, restore, or rebuild any such Work. This remedy is in addition to any other legal or equitable remedies the City may have under this Agreement or the law.

This guarantee and warranty shall not relieve Contractor of liability for latent defects, and shall be in addition to the City's rights under the law or other guarantees or warranties, express or implied.

16.6 The provisions of this Section 16 shall survive the completion, expiration or termination of this Agreement.

## 17 Savings Clause

17.1 If any provision of this Agreement, or the application of such provision, shall be rendered or declared invalid by a court of competent jurisdiction, or by reason of its requiring any steps, actions, or results, the remaining parts or portions of this Agreement shall remain in full force and effect.

## 18 Non-Waiver of Rights

18.1 No failure or delay by the City to exercise any power given to it hereunder or to insist upon strict compliance by Contractor with its obligations hereunder, nor any payment made by the City under this Agreement, shall constitute a waiver of the City's right to demand strict compliance with the terms hereof, unless such waiver is in writing and signed by the City.

## 19 Entire Agreement

19.1 This Agreement sets forth all the covenants, conditions and promises between the parties with regard to the subject matter set forth herein. There are no covenants, promises, agreements, conditions or understandings between the parties, either oral or written, other than those contained in this Agreement. This Agreement has been negotiated and entered into by each party with the opportunity to consult with its counsel regarding the terms therein. No portion of the Agreement shall be construed against a party due to the fact that one party drafted that particular portion as the rule of *contra proferentem* shall not apply.

## 20 Governing Law

20.1 This Agreement shall be construed in accordance with and subject to the laws and rules of the City of Evanston and the State of Illinois both as to interpretation and performance. Venue for any action arising out of or due to this Agreement shall be in Cook County, Illinois. The City shall not enter into binding arbitration to resolve any dispute related to this Agreement. The City does not waive tort immunity by entering into this Agreement.

## 21 Ownership of Contract Documents

21.1 Contractor is specifically prohibited from using in any form or medium, the name or logo of the City for public advertisement, unless expressly granted written permission by the City. Submission or distribution of documents to meet official regulatory requirements or for similar purposes in connection with this Project is not to be construed as publication in derogation of the City's reserved rights.

## 22 Notice

22.1 Any notice required to be given by this Agreement shall be deemed sufficient if made in writing and sent by certified mail, return receipt requested, or by personal service, to the persons and addresses indicated below or to such other addresses as either party hereto shall notify the other party of in writing pursuant to the provisions of this Subsection:

City of Evanston Project Manager, Bid                       
909 Davis Street  
Evanston, Illinois 60201

If to the Contractor:

\_\_\_\_\_

\_\_\_\_\_

22.2 Mailing of such notice as and when provided above shall be equivalent to personal notice and shall be deemed to have been given at the time of mailing.

## 23 Severability

23.1 Except as otherwise provided herein, the invalidity or unenforceability of any particular provision, or part thereof, of this Agreement shall not affect the other provisions, and this Agreement shall continue in all respects as if such invalid or unenforceable provision had not been contained herein.

## 24 Execution of Agreement

24.1 This Agreement shall be signed last by the City Manager.

## 25 Counterparts

25.1 For convenience, this Agreement may be executed in any number of counterparts, each of which shall be deemed to be an original.

## 26 Authorizations

26.1 The Contractor's authorized representatives who have executed this Agreement warrant that they have been lawfully authorized by the Contractor's board of directors or its bylaws to execute this Agreement on its behalf. The City Manager affirms that he/she has been lawfully authorized to execute this Agreement. The Contractor and the City shall deliver upon request to each other copies of all articles of incorporation, bylaws, resolutions, ordinances, or other documents which evidence their legal authority to execute this Agreement on behalf of their respective parties.

## 27 Time of Essence

27.1 Time is of the essence with respect to each provision hereof in which time is a factor.

IN WITNESS WHEREOF, the parties hereto have caused this Agreement to be signed by their duly authorized representatives. The effective date of this Agreement will be the date this Agreement is signed by the City Manager.

**CONTRACTOR**

By: \_\_\_\_\_

Name: \_\_\_\_\_

Its: \_\_\_\_\_

Date: \_\_\_\_\_  
**CITY OF EVANSTON**

By: \_\_\_\_\_

    Luke Stowe  
Its: City Manager

Date: \_\_\_\_\_

Approved as to form:

By: \_\_\_\_\_

    Alexandra B. Ruggie  
Its: Corporation Counsel

Revision: April 2021

**EXHIBIT P**

**BID BOND SUBMITTAL LABEL**

**CUT AND ATTACH LABEL ON OUTSIDE OF SEALED BID BOND SUBMITTAL**

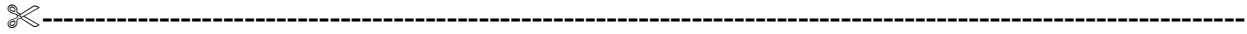

**BID SUBMITTAL NUMBER:** \_\_\_\_\_

**BID SUBMITTAL NAME:** \_\_\_\_\_

\_\_\_\_\_

**BID SUBMITTAL DUE DATE/TIME:** \_\_\_\_\_

**COMPANY NAME:** \_\_\_\_\_

**COMPANY ADDRESS:** \_\_\_\_\_

**COMPANY TELEPHONE #:** \_\_\_\_\_



If required by the bid documents, a scanned copy of the bid bond must be included with the bid electronic submission. The city is currently not able to accept a certified check, bank cashier's check or electronic bid bond at this time.

The original bid bond (in the amount of 5% of the original bid amount) must be mailed within ten (10) days after the bid due date, to the City of Evanston Purchasing Department, 909 Davis Street, Evanston, Illinois 60201 Attention Purchasing Manager using the USPS (certified or priority), UPS or FedEx mail options in order to have a tracking number; which sum shall be forfeited in case the successful bidder fails to enter into a binding contract and provide a properly executed contract and surety bond within 15 days after the date the contract is awarded by the City.

**SECTION 01 00 00  
PROJECT REQUIREMENTS**

**PART 1 – GENERAL**

1.01 GENERAL NOTE

- A. The following requirements are a component part of all contract divisions and form a part of each specification section in so far as they may be in any way applicable thereto.

1.02 RELATED WORK

- A. Drawings and general provisions of the Contract, including General and Supplementary Conditions and all other Divisions of the Project Manual, apply to this section.

1.03 SCHEDULE OF DRAWINGS

- A. The following drawings form a component part of all contract documents for this project.

Title of the Drawings:

| <u>Sheet No.</u> | <u>Drawing Title</u> |
|------------------|----------------------|
|------------------|----------------------|

A1.01 Cover Page & General Notes

A1.02 Demolition & New Work Plans

A1.03 Exterior Elevations, Section, Electrical Plan

1.04 PROJECT SUMMARY

- A. This project includes, but is not limited to the removal and replacement of existing restroom partitions, select plumbing fixtures, light fixtures, hand dryers, doors + frames, restroom wall material, and outdoor drinking fountain. It also includes the expansion of men and women's restrooms by shifting an existing wall as indicated on the drawings, and new polished concrete topping in men and women's restrooms. Plumbing and electrical scope is generally limited to the replacement of existing fixtures without increase in demand loads, and no changes to the existing HVAC system are anticipated.

1.05 SPECIAL PROCEDURES AND REQUIREMENTS

- A. Fire Protection
1. Regulations: The Contractor shall comply with all federal, state and local fire regulations.
  2. Fires: The Contractor shall prohibit the lighting of fires about the premises and use due diligence to see that such prohibition is enforced. Debris and waste materials shall not be burned at the construction site but shall be promptly removed to prevent the accumulation of combustibles on the site.
  3. Smoking: Smoking shall be restricted to designated exterior locations. The Contractor shall furnish and post "NO SMOKING" signs at appropriate locations throughout the site where operations are conducted.
  4. Flammables: Gasoline and other fuels shall be kept and handled from National Board of Fire underwriter's approved safety cans and shall be stored away from hazardous work areas.
- B. Limit of Contractor's Operations
1. Work Areas: Work areas shall be confined to the limits of the construction site. The allotment of work areas within the site to Subcontractors shall be made by the Contractor. The general scheme of operations, work area assignments and use of the job site shall be subject to the Owner's approval.
- C. Site Access: Uncontrolled or unrestricted site access will not be permitted for materials, debris or equipment. All access routes and methods shall be controlled by the Contractor so as to minimize the disruption of the park use by citizen. All site access plans shall be subject to approval by the Owner.
- D. Hoists, Scaffolds and Ladders
1. Hoists: The Contractor shall furnish, erect, operate and maintain suitable hoisting equipment as may be necessary for constructing the work. Material

hoists shall be constructed and maintained in accordance with all applicable federal, state and local laws, regulations and ordinances. Location of hoists shall be subject to approval by the Owner’s representative.

- 2. Scaffolds and Ladders: The Contractor shall furnish, erect, maintain and move all scaffold and ladders required for his work. Scaffolds shall be constructed and maintained in accordance with all applicable federal, state and local laws, regulations and ordinances. Scaffolds and ladders shall be promptly removed after their purpose has been served.

E. Site Security: See Section 01560 Site Security Measures

F. Documentation of Existing Conditions

- 1. Before starting any work, the Contractor shall examine the building to be worked on and the building and grounds in the staging area and areas adjacent to the building that will be worked on for any existing damage. The Contractor should notify the City’s representative of any damage found immediately. The City’s representative will photograph and note any existing damage that has been brought to his attention by the Contractor. After the Work has been completed the City will inspect the area used by the Contractor. If any damage is found that was not reported previously, this damage would be considered to have been done by the Contractor. The cost to repair said damage shall be solely borne by the Contractor.

1.06 TEMPORARY CONSTRUCTION FACILITIES

A. The following temporary utilities and facilities on the construction site shall be provided by the party indicated below:

| <u>ITEM</u>                            | <u>PROVIDER</u>    |
|----------------------------------------|--------------------|
| Telephone                              | General Contractor |
| Electricity                            | General Contractor |
| Water                                  | General Contractor |
| Toilets                                | General Contractor |
| Parking spaces for Contractor vehicles | On the street      |
| Parking spaces for workmen             | On the street      |
| Storage areas & facilities             | General Contractor |
| Job-site trailers & offices            | General Contractor |

**PART 2 – PRODUCTS  
(NOT APPLICABLE)**

**PART 3 – EXECUTION  
(NOT APPLICABLE)**

**END OF SECTION 01 00 00**

**SECTION 01 01 00  
SUMMARY OF WORK**

**PART 1 – GENERAL**

- 1.01 WORK COVERED BY CONTRACT DOCUMENTS
- A. The Project Manual and accompanying drawings are intended to cover the work necessary to construct the various headings of work as described in detail herein.
  - B. The work to be performed under this contract shall consist of the furnishing of all materials, equipment, supplies, labor and transportation, and performing all work as required to strictly conform to the provisions of the specifications, schedules and drawings, all of which are made a part herein, together with such detail drawings as may be furnished by the Owner from time to time during the prosecution of the work in amplification of said drawings and specifications.
- 1.02 RELATED WORK
- A. Drawings and general provisions of the Contract, including General and Supplementary Conditions and all other Divisions of the Project Manual, apply to this section.
- 1.03 CONTRACT ORGANIZATION
- A. This Construction Project is organized under a single contract between the Owner and the Contractor. The Contractor is responsible for all plans and specification sections divisions 0 through 16 as presented in this project manual.
- 1.04 WORK SEQUENCE
- A. All work and sequence of operations shall be as scheduled in conjunction with all subcontractors, and the Owner in such a manner as not to hinder or delay any other contractors in the progress of their work, and to an end that will expedite the work to completion at the earliest possible date.
  - B. Both Contractor and Subcontractor shall cooperate to execute their work as scheduled to minimize the delays to each other and to cause the least inconvenience to the Owner and the public.
- 1.05 CONTRACTORS' USE OF PREMISES
- A. The Contractor shall limit his use of the premises for work and for storage to allow for:
    - 1. Work by other contractors
    - 2. Owner occupancy
  - B. Coordinate the use of the premises under direction of the Owner. Stage work so as to avoid disruption to Owner's operation.
  - C. Assume full responsibility for the protection and safekeeping of products under this Contract, which are stored at the project site or on the Contractor's property.
  - D. Move any stored products, under Contractor's control, which interfere with operation of the Owner or separate contractor.
  - E. Obtain, insure and pay for the use of additional storage or work areas needed for operations.
- 1.06 OWNER OCCUPANCY
- A. Park and children's play area shall be used by citizen during the entire period of construction. Cooperate with the Owner in all construction operations to minimize conflict and to facilitate citizen's usage.
- 1.07 LINES, LEVELS AND LAYOUT OF WORK
- A. The Contractor shall establish and guarantee all lines, levels, etc. called for on the drawings, including the lines, levels, etc. of all Subcontractors.

1.08 WORK HOURS

- A. Work hours permitted is 7:00 am to 7:00 pm, Monday through Friday and 8:00 am to 6:00 pm on Saturday. No work is allowed on Sundays or City holidays. Access to the site will not be allowed outside of normal work hours.

**PART 2 – PRODUCTS  
(NOT APPLICABLE)**

**PART 3 – EXECUTION  
(NOT APPLICABLE)**

**END OF SECTION 01 01 00**

**SECTION 01 02 70  
APPLICATIONS FOR PAYMENT**

**PART 1 – GENERAL**

- 1.01 SUMMARY
- A. Contractor shall comply with procedures described in this Section when applying for progress payments and final payment under the Contract.
- 1.02 RELATED WORK
- A. Drawings and general provisions of the Contract, including General and Supplementary Conditions and all other Divisions of the Project Manual, apply to this Section.
- B. Payments upon Substantial Completion and Completion of the Work are described in Section 01 70 00 – PROJECT CLOSEOUT.
- C. The Owner’s approval of applications for progress payment and final payment may be contingent upon the Owner’s approval of status of Project Record Documents as described in Section 01 72 00 – PROJECT RECORD DOCUMENTS of these Specifications.
- 1.03 QUALITY ASSURANCE
- A. Prior to start of construction, secure the Owner’s approval of the schedule of values required to be submitted as specified below.
- B. During progress of the Work, modify the schedule of values as approved by the Owner to reflect changes in the Contract Sum due to Change Orders or other modifications of the Contract.
- C. All requests for payment shall be based on the approved Schedule of Values for the project.
- D. All modifications to the contract shall be based on the approved Schedule of Values for the project.
- 1.04 SCHEDULE OF VALUES
- A. Coordinate preparation of the Schedule of Values with preparation of the Contractor’s Construction Schedule.
1. Correlate line items in the Schedule of Values with other required administrative schedules and forms, including:
- a. Contractor’s construction schedule.
- b. Application for Payment forms.
- c. List of subcontractors.
- d. Schedule of alternates.
- e. List of products.
- f. List of principal suppliers and fabricators.
- g. Schedule of submittals.
2. Submit the Schedule of Values to the Owner at the earliest feasible date, but in no case later than seven (7) days before the date scheduled for submittal of the initial Application for Payment.
- B. If applicable, the format and content of the Schedule of Values shall match the project’s unit pricing. The Contractor is strongly encouraged to utilize spreadsheet software for preparation of all pay applications.
1. Include the following Project identification on the Schedule of Values:
- a. Project name and location.
- b. Purchase order number.
- c. Contractor’s name and address.
- d. Date of submittal.

2. Arrange the Schedule of Values in tabular form with separate columns to indicate the following for each item listed:
  - a. Itemized description.
  - b. Name of subcontractor.
  - c. Name of manufacturer or fabricator.
  - d. Name of supplier.
  - e. Change Orders (numbers) that have affected value.
  - f. Dollar value.
  - g. Percentage of Contract Sum to the nearest one-hundredth percent, adjusted to total 100 percent.
3. For each part of the Work where an Application for Payment may include materials or equipment, purchased or fabricated and stored, but not yet installed, provide separate line items on the Schedule of Values for initial cost of the materials, for each subsequent stage of completion, and for total installed value of that part of the Work.
4. Show line items for indirect costs and margins on actual costs, only to the extent that such items will be listed individually in Applications for Payment. Each item in the Schedule of Values and Applications for Payment shall be complete including its total cost and proportionate share of general overhead and profit margin.
5. Update and resubmit the Schedule of Values when Change Orders result in a change in the Contract Sum.

#### 1.05 PROCEDURES

- A. Informal submittal
  1. Make informal submittal of request for payment by filling in pertinent portions of AIA Document G702, "Application and Certification for Payment," plus continuation sheet or sheets of AIA Document G703.
  2. Make this preliminary submittal to the Architect and Owner in accordance with the Owner's payment schedule.
  3. Revise the informal submittal of the request for payment as directed by the Owner, initialing all copies.
- B. Formal submittal
  1. Make formal submittal of request for payment by filling in the agreed data, by typewriter or neat lettering in ink, on AIA Document G702, "Application and Certification for Payment," plus continuation sheet(s) of AIA Document G703.
  2. Sign and notarize the Application and Certificate for Payment.
  3. Reference Purchase Order number on Application for Payment
  4. Secure and file with submittal progress waivers for all materials incorporated into and labor and equipment employed on the work before payment requests are processed.
    - a. Prime contract must provide signed and notarized progress waivers and sworn statement prior to processing of payment.
    - b. Initial payment will be processed without progress waivers for subcontracts and material suppliers. Subsequent requests will require progress waivers for previous payment.
  5. Submit the request for payment via email to the owner's project manager with a copy to the project manager from the Architect if applicable.
  6. The Architect and Owner will compare the formal submittal with the approved informal submittal and, when approved, will sign the Application and Certificate for Payment, will make and distribute

required copies. The Owner will disburse directly to the Contractor the amount certified less 10% retainage.

7. Approved formal submittals must be received by the Owner in accordance with the Owner's payment schedule.
8. Certified payroll records must be submitted along with the formal submittal as described in the General Conditions.
9. If the project is subject to the City of Evanston's Local Employment Program (LEP), certified payroll records must be concurrently submitted to the owner's project manager.
10. Certified payroll records always must be concurrently submitted to the Illinois Department of Labor using the Certified Transcript of Payroll Portal.

**PART 2 – PRODUCTS  
(NOT APPLICABLE)**

**PART 3 – EXECUTION  
(NOT APPLICABLE)**

**END OF SECTION 01 02 70**

## **SECTION 01 02 80**

### **CHANGE ORDER PROCEDURE**

#### **PART 1 GENERAL**

##### **1.1 SUMMARY**

- A. Make such changes in the Work, in the Contract Sum, in the Contract Time of Completion, or any combination thereof, as are described in written Change Orders and/or modified Purchase Orders issued by the Owner after execution of the Contract, in accordance with the provisions of this Section.

##### **1.2 RELATED WORK**

- A. Drawings and general provisions of the Contract, including General and Supplementary Conditions and all other Divisions of the Project Manual, apply to this Section.
- B. Changes in the Work are described further in the General Conditions.
- C. Bulletins
  1. From time to time during progress of the Work, the Owner may issue a bulletin or sketch, which interprets the Contract Documents or order minor changes in the Work without change in Contract Sum or Contract Time.
  2. Should the Contractor consider that a change in Contract Sum or Contract Time is required, he shall submit an itemized Proposal to the Owner immediately and before proceeding with the Work. All proposals shall be submitted on the attached forms and shall conform to the requirements, breakdowns and markups identified. If the proposal is found to be satisfactory and in proper order, the Owner will issue a Change Order and/or a modified Purchase Order.
  3. Issuance of a bulletin or sketch is not to be considered a Change Order and is not authorization to proceed with the changes described therein.

##### **1.3 QUALITY ASSURANCE**

- A. The Owner will supply the Contractor with the standard City of Evanston Change Order form as attached.
- B. Include within the Contractor's quality assurance program such measures as are needed to assure familiarity of the Contractor's staff and employees with these procedures for processing Change Order data.
- C. During progress of the Work, modify the Schedule of Values as approved by the Owner to reflect changes in the Contract Sum due to Change Orders.

##### **1.4 DELIVERY, STORAGE AND HANDLING**

- A. Maintain a "Register of bulletins, sketches, supplemental instructions, proposals and change orders" at the job site, accurately reflecting current status of all pertinent data.
- B. Make the Register available to the Owner for review at their request.

##### **1.5 PROCESSING BULLETINS AND PROPOSALS**

- A. Make written reply to the Owner in response to each Bulletin using the standard City of Evanston Change Order Form as attached.

1. The contractor shall break down and describe all work and costs by subcontractors and general contractor in terms of trade, raw costs, markup, subtotal and total.
2. The contractor shall include full backup data such as subcontractor's letter of proposal or similar information.
3. The contractor shall be limited to the following markup percentages
  - a. Item I – subcontractor's markup on own work: 5%
  - b. Item IB – general contractor's overhead on subcontractor's work: 5%
  - c. Item II – general contractors markup on own work: 10%
4. The contractor shall identify any extension of time required to perform the work associated with the proposal on the proposal form. No extension of time will be granted for proposal items after change orders are accepted.
5. The contractor shall sign, date and submit proposal and accompanying backup data to the Owner for review.

B. When the Owner and the Contractor have agreed upon cost or credit for the change, the Owner will issue a Change Order and/or a modified Purchase Order to the Contractor.

#### 1.6 PROCESSING CHANGE ORDERS

- A. Change orders will be numbered in sequence and dated.
  1. The Change Order will describe the change or changes, will refer to the proposal(s) and bulletin(s) involved and will be signed by the Owner and the Contractor.
  2. The Owner will issue two copies of each Change Order to the contractor.
    - a. The Contractor shall promptly sign both copies and return one copy to the Owner.
- B. A modified Purchase Order will be issued with a Change Order, when necessary, in accordance with the General Conditions.

PART 2 PRODUCTS (NOT APPLICABLE)

PART 3 EXECUTION (NOT APPLICABLE)

**CITY OF EVANSTON  
CHANGE ORDER**

Change No. \_\_\_\_\_  
Date: \_\_\_\_\_  
Agreement Date: \_\_\_\_\_

**PROJECT:** \_\_\_\_\_  
**OWNER:** \_\_\_\_\_  
**CONSULTANT:** \_\_\_\_\_

The following changes are hereby made to the **AGREEMENT:**

1. \_\_\_\_\_ Add \_\_\_\_\_ \$

**Total Change** \_\_\_\_\_ \$ \_\_\_\_\_

---

---

Change Order: \_\_\_\_\_ \$

Original **TOTAL CONTRACT PRICE:** \_\_\_\_\_ \$  
Current **CONTRACT PRICE** adjusted by **CHANGE ORDERS** \_\_\_\_\_ \$  
Total change in **CONTRACT PRICE** for this **AMENDMENT** \_\_\_\_\_ \$  
The **CONTRACT PRICE** including this **AMENDMENT** will be \_\_\_\_\_ \$

Original Date for Contract Completion \_\_\_\_\_  
Current Date for Contract Completion \_\_\_\_\_  
Time Extension (in calendar days) \_\_\_\_\_  
Modified Date for Contract Completion \_\_\_\_\_

Approved by  
(Owner): \_\_\_\_\_  
City of Evanston \_\_\_\_\_ Date \_\_\_\_\_

Accepted by  
(Contractor): \_\_\_\_\_  
Contractor \_\_\_\_\_ Date \_\_\_\_\_

END OF SECTION 01 02 80

**SECTION 01 06 00  
REGULATORY REQUIREMENTS**

**PART 1 – GENERAL**

1.01 SUMMARY

- A. Contractors shall comply with all laws, rules and regulations governing the Work.
  - 1. When Contractor observes that Contract Documents are in variance with specified codes, notify the Owner in writing immediately. The Owner will issue all changes in accord with the General Conditions.
  - 2. When Contractor performs any Work knowing or having reason to know that the Work is contrary to such laws, rules and regulations and fails to so notify the Owner, the Contractor shall pay all costs arising therefrom. However, it will not be the Contractor's primary responsibility to make certain that the Contract Documents are in accord with such laws, rules and regulations.

1.02 RELATED WORK

- A. Drawings and general provisions of the Contract, including General and Supplementary Conditions and all other Divisions of the Project Manual, apply to this Section.

1.03 DEFINITIONS AND ABBREVIATIONS

- A. Definitions
  - 1. "Codes" means rules, regulations or statutory requirements of government agencies.
  - 2. "Standards" means requirements set by authorities, custom or general consent and establish accepted criteria.
- B. Abbreviations
  - 1. ADA Americans with Disabilities Act
  - 2. AGCI Associated General Contractors in Illinois
  - 3. ANSI American National Standards Institute
  - 4. ASHRAE American Society of Heating, Refrigeration and Air Conditioning Engineers
  - 5. ASTM American Society of Testing and Materials
  - 7. COE City of Evanston
  - 8. CPSC Consumer Product Safety Commission (Federal)
  - 9. FM Factory Mutual Engineering Corp.
  - 9. IBC Internation Building Code
  - 10. IDOL Illinois Department of Labor
  - 11. IDOT Illinois Department of Transportation
  - 12. IDPH Illinois Department of Public Health
  - 13. IEPA Illinois Environmental Protection Agency
  - 14. IECC Internation Energy Conservation Code
  - 14. ISPE Illinois Society of Professional Engineers
  - 15. NFPA National Fire Protection Association
  - 16. SFM Office of State Fire Marshall
  - 17. UL Underwriters Laboratories, Inc.

1.04 QUALITY ASSURANCE

- A. Contractor shall:
  - 1. Ensure that copies of specified codes and standards are readily available to Contractor's personnel. Copies are available at Contractor's expense from source or publisher.
  - 2. Ensure that Contractor's personnel are familiar with workmanship and installation requirements of specified codes and standards.

1.05 REFERENCE SPECIFICATIONS

- A. The Specifications referred to herein shall be interpreted to mean the following and shall include all addenda, changes to, etc. Reference to Engineer shall mean Owner.

1. “Standard Specifications” – The Illinois Department of Transportation’s (IDOT’s) “Standard Specifications for Road and Bridge Construction”, latest edition.
2. “Supplemental Specifications” – IDOT’s “Supplemental Specifications and Recurring Special Provisions”, latest edition.
3. “Traffic Specifications” – IDOT’s “Standard Specifications for Traffic Control Items”, latest edition.
4. “Standard Sewer Specifications” – The “Standard Specifications for Water and Sewer Main Construction in Illinois”, latest edition.

1.06 REGULATORY REQUIREMENTS

- A. Source and requirements:
1. EBA: “Environmental Barriers Act” Illinois Accessibility Code
  2. ADA: Americans with Disabilities Act
  3. ISPC: Illinois State Plumbing Code, current edition
  4. IEPA: (current editions at date of bidding documents)
    - a. Air Pollution Standards
    - b. Noise Pollution Standards
    - c. Water Pollution Standards
    - d. Public Water Supplies
    - e. Solid Waste Standards
    - f. Illinois Recommended Standards for Sewage Work
  5. Illinois Purchasing Act, as amended (Illinois Compiled Statutes, 30 ILCS 505/1 et seq)
  6. OSFM:
    - a. Gasoline and Volatile Oils (Illinois Compiled Statutes, 430 ILCS 15/0.01 et seq)
    - b. Liquefied Petroleum Gases (Illinois Compiled Statutes, 430 ILCS 5/0.01 et seq)
    - c. Liquefied Petroleum Gas Containers (Illinois Compiled Statutes, 430 ILCS 10/0.01 et seq)
    - d. Boiler and Pressure Vessel Safety Act and Rules and Regulations (Illinois Compiled Statutes, 430 ILCS 75/1 et seq)
    - e. Illinois Rules and Regulations for Fire Prevention and Safety, as amended 24 December 1973.
  7. CODES:
    - a. City of Evanston “City Ordinances” and “Building Code”, current editions.
    - b. Work not covered by above codes: Use NFPA National Fire Codes, current edition.
- B. The Owner may reference other codes or standards throughout the Project Manual when deemed appropriate for proper compliance with regulatory requirements.

**PART 2 – PRODUCTS  
(NOT APPLICABLE)**

**PART 3 – EXECUTION  
(NOT APPLICABLE)**

**END OF SECTION 01 06 00**

**SECTION 12 00 00  
PROJECT MEETINGS**

**PART 1 – GENERAL**

- 1.01 SUMMARY
- A. This section specifies administrative and procedural requirements for project meetings including but not limited to:
    - 1. Pre-construction Conference
    - 2. Pre-installation Conferences
    - 3. Coordination Meetings
    - 4. Progress Meetings
  - B. Construction schedules are specified in Section 01300 – SUBMITTALS.
- 1.02 RELATED WORK
- A. Drawings and general provisions of the Contract, including General and Supplementary Conditions and all other Divisions of the Project Manual, apply to this Section.
- 1.03 PRE-COSTRUCTION CONFERENCE
- A. The Owner shall schedule a pre-construction conference and organizational meeting at the Project site or other convenient location no later than 15 days after execution of the Agreement and prior to commencement of construction activities. Conduct the meeting to review responsibilities and personnel assignments.
  - B. Attendees: The Owner, the Contractor and its superintendent, major subcontractors, manufacturers, suppliers and other concerned parties shall each be represented at the conference by persons familiar with and authorized to conduct matters relating to the Work.
  - C. Agenda: Discuss items of significance that could affect progress including such topics as:
    - 1. Tentative construction schedule
    - 2. Critical Work sequencing
    - 3. Designation of responsible personnel
    - 4. Procedures for processing field decisions and Change Orders
    - 5. Procedures for processing Applications for Payment
    - 6. Distribution of Contract Documents
    - 7. Submittal of Shop Drawings, Product Data and Samples
    - 8. Preparation of record documents
    - 9. Use of the premises
    - 10. Office, Work and storage areas
    - 11. Equipment deliveries and priorities
    - 12. Safety procedures
    - 13. First aid
    - 14. Security
    - 15. Housekeeping
    - 16. Construction activity policies and working hours
    - 17. MBE/WBE/EBE requirements
    - 18. Coordination with affected utilities and governing jurisdictions
- 1.04 PRE-INSTALLATION CONFERENCE
- A. Conduct a pre-installation conference at the site before each construction activity that requires coordination with other construction. The installer and representatives of manufacturers and fabricators involved in or affected by the installation, and its coordination or integration with other materials and installations that have preceded or will follow, shall attend the meeting. Advise the Owner of scheduled meeting dates.
  - B. Review the progress of other construction activities and preparations for the particular activity under consideration at each pre-installation conference, including requirements for:
    - 1. Contract Documents
    - 2. Options
    - 3. Related Change Orders

4. Purchases
  5. Deliveries
  6. Shop Drawings, Product Data and quality control samples
  7. Possible conflicts
  8. Compatibility problems
  9. Time schedules
  10. Weather limitations
  11. Manufacturer's recommendations
  12. Compatibility of materials
  13. Acceptability of substrates
  14. Temporary facilities
  15. Space and access limitations
  16. Governing regulations
  17. Safety
  18. Inspection and testing requirements
  19. Required performance results
  20. Recording requirements
  21. Protection
- C. Record significant discussions and agreements and disagreements of each conference, along with the approved schedule. Distribute the record of the meeting to everyone concerned, promptly, including the Owner.
- D. Do not proceed if the conference cannot be successfully concluded. Initiate whatever actions are necessary to resolve impediments to performance of Work and reconvene the conference at the earliest feasible date.
- 1.05 PROGRESS MEETINGS (Minimum one (1) per week)
- A. Conduct progress meetings at the Project site at regularly scheduled intervals. Notify the Owner of scheduled meeting dates. Coordinate dates of meetings with preparation of the payment requests.
  - B. Attendees: in addition to the Owner, each subcontractor, supplier or other entity concerned with current progress or involved in planning, coordination or performance of future activities shall be represented at these meetings by persons familiar with the Project and authorized to conclude matters relating to progress.
  - C. Agenda: Review and correct or approve minutes of the previous progress meeting. Review other items of significance that could affect progress. Include topics for discussion as appropriate to the current status of the Project.
  - D. Contractor's Construction Schedule: review progress since the last meeting. Determine where each activity is in relation to the Contractor's Construction Schedule, whether on time, ahead or behind schedule. Determine how construction behind schedule will be expedited; secure commitments from parties involved to do so. Discuss whether schedule revisions are required to ensure that current and subsequent activities will be completed within the Contract Period.
  - E. Review the present and future needs of each entity present, including such items as:
    1. Interface requirements
    2. Time
    3. Sequences
    4. Deliveries
    5. Off-site fabrication problems
    6. Access
    7. Site utilization
    8. Temporary facilities and services
    9. Hours of Work
    10. Hazards and risks
    11. Housekeeping
    12. Quality and Work standards
    13. Change Orders
    14. Documentation of information for payment requests.

- F. Reporting: no later than three (3) days after each progress meeting date, distribute copies of minutes of the meeting to each party present and to other parties who should have been present. Include a brief summary, in narrative form, of progress since the previous meeting and report.
- G. Schedule Updating: revise the construction schedule after each progress meeting where revisions to the schedule have been made or recognized. Issue the revised schedule concurrently with the report of each meeting.

**PART 2 – PRODUCTS  
(NOT APPLICABLE)**

**PART 3 – EXECUTION  
(NOT APPLICABLE)**

**END OF SECTION 0120**



**SECTION 01 21 00  
ALLOWANCES**

**PART 1 – GENERAL**

**1.1 RELATED DOCUMENTS**

- A. Drawings and general provisions of the Contract, including General and Supplementary Conditions and other Division 1 Specification Sections, apply to this Section.
- B. Other provisions concerning Allowances also may be stated in other Sections of these Specifications.

**1.2 SUMMARY**

- A. The allowance is general and is to be used to provide adequate budget and bonding to cover items not able to be precisely determined by the Owner prior to bidding including any unforeseen conditions that are discovered. Allow within the proposed Total Base Bid Amount the amounts described in this Section.
- B. Unless otherwise provided in the Contract Documents:
  - 1. Allowances shall cover the cost to the Contractor of materials and equipment delivered at the site and all required taxes, less applicable trade discounts.
  - 2. Contractor's cost for unloading and handling at the site, labor, installation costs, overhead, profit, and similar costs related to products and materials ordered by the Owner and selected by the Consultant under an allowance shall be included in the Lump Sum Base Bid Amount and not as a part of the allowance.
  - 3. Allowance work and estimated costs shall be pre-approved prior to the start of and during the Construction with Proposals documenting the work to be performed, with clearly stated not-to-exceed estimates and step by step method of procedures for the proposed work stated on the forms provided in the Contract Documents. Proposals must be submitted and accepted by the Owner prior to starting any allowance work. After discovering an unforeseen condition, the contractor shall submit a Proposal that includes a report summarizing the found condition. The Consultant and Owner will view the unforeseen condition to determine if the work will be authorized. Allowance work shall only be authorized by written Change Order. Under no circumstances shall the Contractor move forward with the work in question nor shall the contractor expend allowance without an approved Change Order.

**1.3 ALLOWANCE RESPONSIBILITIES**

- A. Owner's Responsibilities:
  - 1. Consult with Contractor in consideration and selection of products, suppliers and installers.
  - 2. Select products or services.

3. Review method of procedure and estimated maximum costs documented on Proposals submitted by the Contractor and transmit decision to Contractor. Owner approved Change Orders are required prior to proceeding with Allowance Work.
  4. Review, recommend and transmit Change Orders for approval.
  5. Transmit decision to the Contractor.
- B. Contractor's Responsibilities:
1. Assist Owner in selection of products, suppliers and installers.
  2. Obtain proposals from suppliers and installers and offer recommendations and review of proposals submitted. Transmit to Owner on Proposal forms provided in Contract Documents, attaching all supporting documentation. Include any bond cost adjustments with the proposal. Include scheduling information and assessment of impact of other work.
  3. On notification of selection by Owner's representative, execute purchase agreement with designated supplier and installer.
  4. Arrange for and process shop drawings, product data and samples. Arrange for delivery.
  5. Promptly inspect products upon delivery for completeness, damage and defects. Submit claims for transportation damage.
  6. Document thoroughly all costs related to the work.
  7. Advise the Owner immediately of any material changes in estimated cost, scope or timing. Contractor may not exceed estimated maximum cost without written acceptance by Owner.
  8. Provide the Owner with fully documented Change Orders detailing all allowance work performed. Including all documentation required.

#### 1.4 ALLOWANCE DOCUMENTATION

- A. All work covered by Allowances must be thoroughly documented as follows:
1. Upon encountering Allowance work or any field conditions which is not as shown in Construction Documents, the Contractor shall immediately notify the Owner and develop a written Proposal detailing any additional work required. Proposals shall include a report summarizing the found condition to the Owner. Contractor work initiated without submitting a completed Proposal and obtaining the Owner's written approval by Change Order is performed entirely at Contractor's own risk and cost, regardless of any prior verbal approval.
  2. The Owner shall review the Contractor's Proposal and, if appropriate, provide written approval via Change Order for use of the Allowance.

#### 1.5 SCHEDULE OF ALLOWANCES

**Allowance Number 1, Additional Work General: \$15,000.00**

1.6 ALLOWANCE EXCLUSIONS

A. General

1. Additional costs related to improper scheduling, sequencing or coordination will not be covered within the Allowance, as determined solely by the Owner.

C. Existing Building Component Exclusions

1. All work required to protect existing building surfaces and components is included in the Base Bid and will not be covered within the Allowance.

**PART 2 – PRODUCTS  
(Not Used)**

**PART 3 – EXECUTION  
(Not Used)**

**END OF SECTION 01210**

**SECTION 01 29 00  
APPLICATIONS FOR PAYMENT**

**PART 1 – GENERAL**

- 1.01 SUMMARY
- A. Contractor shall comply with procedures described in this Section when applying for progress payments and final payment under the Contract.
- 1.02 RELATED WORK
- A. Drawings and general provisions of the Contract, including General and Supplementary Conditions and all other Divisions of the Project Manual, apply to this Section.
- B. Payments upon Substantial Completion and Completion of the Work are described in Section 01 70 00 – PROJECT CLOSEOUT.
- C. The Owner’s approval of applications for progress payment and final payment may be contingent upon the Owner’s approval of status of Project Record Documents as described in Section 01 72 00 – PROJECT RECORD DOCUMENTS of these Specifications.
- 1.03 QUALITY ASSURANCE
- A. Prior to start of construction, secure the Owner’s approval of the schedule of values required to be submitted as specified below.
- B. During progress of the Work, modify the schedule of values as approved by the Owner to reflect changes in the Contract Sum due to Change Orders or other modifications of the Contract.
- C. All requests for payment shall be based on the approved Schedule of Values for the project.
- D. All modifications to the contract shall be based on the approved Schedule of Values for the project.
- 1.04 SCHEDULE OF VALUES
- A. Coordinate preparation of the Schedule of Values with preparation of the Contractor’s Construction Schedule.
1. Correlate line items in the Schedule of Values with other required administrative schedules and forms, including:
- a. Contractor’s construction schedule.
- b. Application for Payment forms.
- c. List of subcontractors.
- d. Schedule of alternates.
- e. List of products.
- f. List of principal suppliers and fabricators.
- g. Schedule of submittals.
2. Submit the Schedule of Values to the Owner at the earliest feasible date, but in no case later than seven (7) days before the date scheduled for submittal of the initial Application for Payment.
- B. If applicable, the format and content of the Schedule of Values shall match the project’s unit pricing. The Contractor is strongly encouraged to utilize spreadsheet software for preparation of all pay applications.
1. Include the following Project identification on the Schedule of Values:
- a. Project name and location.
- b. Purchase order number.
- c. Contractor’s name and address.
- d. Date of submittal.

2. Arrange the Schedule of Values in tabular form with separate columns to indicate the following for each item listed:
  - a. Itemized description.
  - b. Name of subcontractor.
  - c. Name of manufacturer or fabricator.
  - d. Name of supplier.
  - e. Change Orders (numbers) that have affected value.
  - f. Dollar value.
  - g. Percentage of Contract Sum to the nearest one-hundredth percent, adjusted to total 100 percent.
3. For each part of the Work where an Application for Payment may include materials or equipment, purchased or fabricated and stored, but not yet installed, provide separate line items on the Schedule of Values for initial cost of the materials, for each subsequent stage of completion, and for total installed value of that part of the Work.
4. Show line items for indirect costs and margins on actual costs, only to the extent that such items will be listed individually in Applications for Payment. Each item in the Schedule of Values and Applications for Payment shall be complete including its total cost and proportionate share of general overhead and profit margin.
5. Update and resubmit the Schedule of Values when Change Orders result in a change in the Contract Sum.

#### 1.05 PROCEDURES

- A. Informal submittal
  1. Make informal submittal of request for payment by filling in pertinent portions of AIA Document G702, "Application and Certification for Payment," plus continuation sheet or sheets of AIA Document G703.
  2. Make this preliminary submittal to the Architect and Owner in accordance with the Owner's payment schedule.
  3. Revise the informal submittal of the request for payment as directed by the Owner, initialing all copies.
- B. Formal submittal
  1. Make formal submittal of request for payment by filling in the agreed data, by typewriter or neat lettering in ink, on AIA Document G702, "Application and Certification for Payment," plus continuation sheet(s) of AIA Document G703.
  2. Sign and notarize the Application and Certificate for Payment.
  3. Reference Purchase Order number on Application for Payment
  4. Secure and file with submittal progress waivers for all materials incorporated into and labor and equipment employed on the work before payment requests are processed.
    - a. Initial payment will be processed without progress waivers. Subsequent requests will require progress waivers for previous payment.
  5. Submit the request for payment via email to the owner's project manager with a copy to the project manager from the Architect if applicable.
  6. The Architect and Owner will compare the formal submittal with the approved informal submittal and, when approved, will sign the Application and Certificate for Payment, will make and distribute required copies. The Owner will disburse directly to the Contractor the amount certified less 10% retainage.

7. Approved formal submittals must be received by the Owner in accordance with the Owner's payment schedule.
8. Certified payroll records must be submitted along with the formal submittal as described in the General Conditions.
9. If the project is subject to the City of Evanston's Local Employment Program (LEP), certified payroll records must be concurrently submitted to the owner's project manager.
10. Certified payroll records always must be concurrently submitted to the Illinois Department of Labor using the Certified Transcript of Payroll Portal.

**PART 2 – PRODUCTS  
(NOT APPLICABLE)**

**PART 3 – EXECUTION  
(NOT APPLICABLE)**

**END OF SECTION 01 29 00**

**SECTION 01 30 00  
SUBMITTALS**

**PART 1 – GENERAL**

1.01 SUMMARY

- A. This section specifies administrative and procedural requirements for submittals required for performance of the Work, including:
  - 1. Contractor’s construction schedule
  - 2. Submittal schedule
  - 3. Daily construction reports
  - 4. Product Data
  - 5. Samples
- B. Administrative Submittals: refer to other Division 0 and 1 sections and other Contract Documents for requirements for administrative submittals. Such submittals include but are not limited to:
  - 1. Permits
  - 2. Applications for payment
  - 3. Performance and payment bonds
  - 4. Insurance certificates
  - 5. List of subcontractors
- C. The Schedule of Values submittal is included in Section 1027 – APPLICATION FOR PAYMENT.

1.02 RELATED WORK

- A. Drawing and general provisions of the Contract, including General and Supplementary Conditions and all other Divisions of the Project Manual, apply to this Section.

1.03 SUBMITTAL PROCEDURES

- A. Coordination: coordinate preparation and processing of submittals with performance of construction activities. Transmit each submittal sufficiently in advance of performance of related construction activities to avoid delay.
  - 1. Coordinate each submittal with fabrication, purchasing, testing, delivery, other submittals and related activities that require sequential activity.
  - 2. Coordinate transmittal of different types of submittals for related elements of the Work so processing will not be delayed by the need to review submittals concurrently for coordination.
    - a. The Owner reserves the right to withhold action on a submittal requiring coordination with other submittals until related submittals are received.
  - 3. Processing: allow sufficient review time so that installation will not be delayed as a result of the time required to process submittals, including time for re-submittals.
    - a. Allow two weeks for initial review. Allow additional time if processing must be delayed to permit coordination with subsequent submittals. The Owner will promptly advise the Contractor when a submittal being processed must be delayed for coordination.
    - b. If an intermediate submittal is necessary, process the same as the initial submittal.
    - c. Allow two weeks for re-processing each submittal.
    - d. No extension of Contract Time will be authorized because of failure to transmit submittals to the Owner sufficiently in advance of the Work to permit processing.
- B. Submittal Preparation: place a permanent label or title block on each submittal for identification. Indicate the name of the entity that prepared each submittal on the label or title block.
  - 1. Provide a space approximately 4” x 5” on the label to record the Contractor’s review and approval markings and the action taken.

2. Include the following information on the label for processing and recording action taken.
    - a. Project name
    - b. Date
    - c. Name and address of Owner
    - d. Name and address of Contractor
    - e. Name and address of subcontractor
    - f. Name and address of supplier
    - g. Name of manufacturer
    - h. Number and title of appropriate Specification Section
    - i. Drawing number and detail reference, as appropriate
  - C. Submittal Transmittal: package each submittal appropriately for transmittal and handling. Transmit each submittal from Contractor to Owner using a transmittal form. Submittals received from sources other than the Contractor will be returned without action.
    1. On the transmittal record relevant information and requests for data. On the form, or separate sheet, record deviations from Contract Document requirements, including minor variations and limitations. Include Contractor's certification that information complies with Contract Document requirements.
    2. Transmittal Form: use AIA Document G 810.
- 1.04 **CONTRACTOR'S CONSTRUCTION SCHEDULE**
- A. Bar-Chart Schedule: prepare a fully developed, horizontal bar-chart type Contractor's construction schedule. Submit within 30 days of the date established for "Commencement of the Work".
    1. Provide a separate time bar for each significant construction activity. Provide a continuous vertical line to identify the first working day of each week. Use the same breakdown of units of the Work as indicated in the "Schedule of Values".
    2. Within each time bar indicate estimated completion percentage in 10 percent increments. As Work progresses, place a contrasting mark in each bar to indicate Actual Completion.
    3. Prepare a schedule on a sheet, or series of sheets, of stable transparency, or other reproducible media, of sufficient width to show data for the entire construction period.
    4. Secure time commitments for performing critical elements of the Work from parties involved. Coordinate each element on the schedule with other construction activities; include minor elements involved in the sequence of the Work. Show each activity in proper sequence. Indicate graphically sequences necessary for completion of related portions of the Work.
    5. Coordinate the Contractor's construction schedule with the schedule of values, list of subcontracts, submittal schedule, progress report, payment requests and other schedules.
    6. Indicate completion in advance of the date established for Substantial Completion. Indicate Substantial Completion on the schedule to allow time for Owner's procedures necessary for certification of Substantial Completion.
  - B. Phasing: Provide notations on the schedule to show how the sequence of the Work is affected by requirements for phased completion to permit Work by separate Contractors and partial occupancy by the Owner prior to Substantial Completion.
  - C. Work Stages: Indicate important stages of construction for each major portion of the Work, including testing and installation.
  - D. Area Separations: Provide a separate time bar to identify each major construction area for each major portion of the Work. Indicate where each element in an area must be sequenced or integrated with other activities.
  - E. Cost Correlation: At the head of the schedule, provide a two item cost correlation line, indicating "pre-calculated" and "actual" costs. On the line show dollar-volume of Work performed as of the dates used for preparation of payment requests.
    1. Refer to Section 01027 - APPLICATION FOR PAYMENT for cost reporting and payment procedures.

- F. Distribution: Following response to the initial submittal, print and distribute copies to the Owner, subcontractors, and other parties required to comply with scheduled dates. Post copies in the Project meeting room and temporary field office.
    - 1. When revisions are made, distribute to the same parties and post in the same locations. Delete parties from distribution when they have completed their assigned portion of the Work and are no longer involved in construction activities.
  - G. Schedule Updating: Revise the schedule after each meeting or activity, where revisions have been recognized or made. Issue the updated schedule concurrently with report of each meeting.
- 1.05 SUBMITTAL SCHEDULE
- A. After development and acceptance of the Contractor's construction schedule, prepare a complete schedule of submittals. Submit the schedule within 10 days of the date required for establishment of the Contractor's construction schedule.
    - 1. Coordinate submittal schedule with the list of subcontracts, schedule of values and the list of products as well as the Contractor's construction schedule.
    - 2. Prepare the schedule in chronological order; include submittals required during the construction. Provide the following information:
      - 1. Scheduled date for the first submittal.
      - 2. Related Section number.
      - 3. Submittal category.
      - 4. Name of subcontractor.
      - 5. Description of the part of the Work covered.
      - 6. Scheduled date for resubmittal
      - 7. Scheduled date of the Owner's final release or approval.
  - B. Distribution: Following response to initial submittal, print and distribute copies to the Owner, subcontractors, and other parties required to comply with submittal dates indicated. Post copies in the Project meeting room and field office
    - 1. When revisions are made, distribute to the same parties and post in the same locations. Delete parties from distribution when they have completed their assigned portion of the Work and are no longer involved in construction activities.
  - C. Schedule Updating: Revise the schedule after each meeting or activity, where revisions have been recognized or made. Issue the updated schedule concurrently with report of each meeting.
- 1.06 DAILY CONSTRUCTION REPORTS
- A. Prepare a daily construction report, recording the following information concerning events at the site; and submit duplicate copies to the Owner at weekly intervals:
    - 1. List of subcontractors at the site.
    - 2. Approximate count of personnel at the site.
    - 3. High and low temperatures, general weather conditions.
    - 4. Accidents and unusual events.
    - 5. Meetings and significant decisions.
    - 6. Stoppages, delays, shortages, losses.
    - 7. Meter readings and similar recordings.
    - 8. Emergency procedures.
    - 9. Orders and requests of governing authorities.
    - 10. Change Orders received, implemented.
    - 11. Services connected, disconnected.
    - 12. Equipment or system tests and start-ups.
    - 13. Partial Completions, occupancies.
    - 14. Substantial Completions authorized.
- 1.07 PRODUCT DATA
- A. Collect Product Data into a single submittal for each element of construction or system. Product Data includes printed information such as manufacturer's installation instructions, catalog cuts, standard color charts, roughing-in diagrams and templates,

standard wiring diagrams and performance curves. Where Product Data must be specially prepared because standard printed data is not suitable for use, submit as "Shop Drawings."

1. Mark each copy to show applicable choices and options. Where printed Product Data includes information on several products, some of which are not required, mark copies to indicate the applicable information. Include the following information:
  - a. Manufacturer's printed recommendations.
  - b. Compliance with recognized trade association standards.
  - c. Compliance with recognized testing agency standards.
  - d. Application of testing agency labels and seals.
  - e. Notation of dimensions verified by field measurement.
  - f. Notation of coordination requirements.
2. Do not submit Product Data until compliance with requirements of the Contract Documents has been confirmed.
3. Preliminary Submittal: Submit a preliminary single-copy of Product Data where selection of options is required.
4. Submittals: Submit 2 copies of each required submittal; submit 4 copies where required for maintenance manuals. The Owner will retain one, and will return the other marked with action taken and corrections or modifications required.
  - a. Unless noncompliance with Contract Document provisions is observed, the submittal may serve as the final submittal.
5. Distribution: Furnish copies of final submittal to installers, subcontractors, suppliers, manufacturers, fabricators, and others required for performance of construction activities. Show distribution on transmittal forms.
  - a. Do not proceed with installation until an applicable copy of Product Data applicable is in the installer's possession.
  - b. Do not permit use of unmarked copies of Product Data in connection with construction.

#### 1.08 SAMPLES

- A. Submit full-size, fully fabricated Samples cured and finished as specified and physically identical with the material or product proposed. Samples include partial sections of manufactured or fabricated components, cuts or containers of materials, color range sets, and swatches showing color, texture and pattern.
  1. Mount, display, or package Samples in the manner specified to facilitate review of qualities indicated. Prepare Samples to match the Owner's Sample. Include the following:
    - a. Generic description of the Sample.
    - b. Sample source.
    - c. Product name or name of manufacturer.
    - d. Compliance with recognized standards.
    - e. Availability and delivery time.
  2. Submit Samples for review of kind, color, pattern, and texture, for a final check of these characteristics with other elements, and for a comparison of these characteristics between the final submittal and the actual component as delivered and installed.
    - a. Where variation in color, pattern, texture or other characteristics are inherent in the material or product represented, submit multiple units (not less than 3), that show approximate limits of the variations.
    - b. Refer to other Specification Sections for requirements for Samples that illustrate workmanship, fabrication techniques, details of assembly, connections, operation and similar construction characteristics.
    - c. Refer to other Sections for Samples to be returned to the Contractor for incorporation in the Work. Such Samples must be undamaged at time of use. On the transmittal, indicate special requests regarding disposition of Sample submittals.

3. Preliminary submittals: Where Samples are for selection of color, pattern, texture or similar characteristics from a range of standard choices, submit a full set of choices for the material or product.
    - a. Preliminary submittals will be reviewed and returned with the Owner's mark indicating selection and other action.
  4. Submittals: Except for Samples illustrating assembly details, workmanship, fabrication techniques, connections, operation and similar characteristics, submit 3 sets; one will be returned marked with the action taken.
  5. Maintain sets of Samples, as returned, at the Project site, for quality comparisons throughout the course of construction.
    - a. Unless noncompliance with Contract Document provisions is observed, the submittal may serve as the final submittal.
    - b. Sample sets may be used to obtain final acceptance of the construction associated with each set.
- B. Distribution of Samples: Prepare and distribute additional sets to subcontractors, manufacturers, fabricators, suppliers, installers, and others as required for performance of the Work. Show distribution on transmittal forms.
- C. Mock ups specified in individual Sections are special types of Samples. Mock ups are full-size examples erected on site to illustrate finishes, coatings, or finish materials and to establish the standard by which the Work will be judged.
- D. Comply with submittal requirements to the fullest extent possible. Process transmittal forms to provide a record of activity.
- 1.09 CONTRACTOR'S RESPONSIBILITIES
- A. Review product data and samples prior to submission.
  - B. Verify:
    1. Field dimensions
    2. Field construction criteria
    3. Catalog numbers and similar data
  - C. Coordinate each submittal with requirements of Work and of Contract Documents.
  - D. Contractor's responsibility for errors and omissions in submittals is not relieved by Owner's review of submittals.
  - E. Contractor's responsibility for deviations in submittals from Contract Document requirements is not relieved by Owner's review of submittals.
  - F. Notify Owner in writing at time of submission, of deviations in submittals from contract requirements.
  - G. Do not begin any work which requires submittals without having Owner's stamp and initials or signature indicating review.
  - H. After Owner's review, make response required by Owner, stamp and distribute copies.
- 1.10 SUBMISSION REQUIREMENTS
- A. Make all submissions within 15 business days after date of Notice to Proceed.
  - B. Submit number of copies of project data and samples which Contractor requires for distribution plus 3 copies which will be retained by the Owner.
  - C. Submit number of samples specified in each of specification sections.
  - D. Accompany submittals with transmittal letter, in duplicate, containing:
    1. Date
    2. Project title and number
    3. Contractor's name and address
    4. The number of each shop drawing, product datum and sample submitted
    5. Notification of deviations from contract
    6. Other pertinent data
  - E. Submittals shall include:
    1. Date and revision dates
    2. Project title and number
    3. Names of:
      - a. Contractor
      - b. Subcontractor

- c. Supplier
  - d. Manufacturer
  - e. Separate detailer when pertinent
  - 4. Identification of product or material
  - 5. Relation to adjacent structure or material
  - 6. Field dimensions, clearly identified as such
  - 7. Specification Section and page number
  - 8. Applicable standards, such as ASTM number or federal specification
  - 9. Identification of deviation(s) from Contract Documents
  - 10. Contractor's stamp, initialed or signed, certifying to review of submittal, verification of field measurements, and compliance with Contract.
- 1.11 RESUBMISSION REQUIREMENTS
- A. Product Data and Samples:  
Submit new datum and samples as required for initial submittal.
  - B. Make all resubmittals within 10 business days after date on Owner's stamp.
- 1.12 DISTRIBUTION OF SUBMITTALS AFTER REVIEW
- A. Distribute copies of project datum which carry Owner's stamp:
    - 1. Contractor's file
    - 2. Job site file
    - 3. Record documents file
    - 4. Subcontractors
    - 5. Supplier
  - B. Distribute samples as directed.
- 1.13 OWNER'S ACTION
- A. Except for submittals for record, information or similar purposes, where action and return is required or requested, the Owner will review each submittal, mark to indicate action taken, and return promptly.
    - 1. Compliance with specified characteristics is the Contractor's responsibility.
  - B. Action Stamp: The Owner will stamp each submittal with a uniform, self-explanatory action stamp. The stamp will be appropriately marked, as follows, to indicate the action taken:
    - 1. Final Unrestricted Release: Where submittals are marked "Furnish as Submitted," that part of the Work covered by the submittal may proceed provided it complies with requirements of the Contract Documents; final acceptance will depend upon that compliance.
    - 2. Final-But-Restricted Release: When submittals are marked "Furnish as Corrected," that part of the Work covered by the submittal may proceed provided it complies with notations or corrections on the submittal and requirements of the Contract Documents; final acceptance will depend on that compliance.
    - 3. Returned for Resubmittal: When submittal is marked "Revise and Resubmit", do not proceed with that part of the Work covered by the submittal, including purchasing, fabrication, delivery, or other activity. Revise or prepare a new submittal in accordance with the notations; resubmit without delay. Repeat if necessary to obtain a different action mark.
    - 4. Returned, Improper Submittal: When submittal is marked "Rejected" do not proceed with that part of the Work covered by the submittal, including purchasing, fabrication delivery or other activity. The submittal does not conform with project requirements. Prepare a new submittal without delay.
    - 5. Do not permit submittals marked "Rejected, Revise and Resubmit" to be used at the Project site, or elsewhere where Work is in progress.
    - 6. Other Action: Where a submittal is primarily for information or record purposes, special processing or other activity, the submittal will be returned, marked "Action Not Required".

**PART 2 – PRODUCTS  
(NOT APPLICABLE)**

**PART 3 – EXECUTION  
(NOT APPLICABLE)**

**END OF SECTION 01 30 00**



**SECTION 01 40 00  
QUALITY REQUIREMENTS**

**PART 1 - GENERAL**

1.01 SUMMARY

- A. This Section specifies administrative and procedural requirements for quality control services.
- B. Quality control services include inspections and tests and related actions including reports, performed by independent agencies, governing authorities, and the Contractor. They do not include Contract enforcement activities performed by the Owner.
- C. Inspection and testing services are required to verify compliance with requirements specified or indicated. These services do not relieve the Contractor of responsibility for compliance with Contract Document requirements.
- D. Requirements of this Section relate to customized fabrication and installation procedures, not production of standard products.
  - 1. Specific quality control requirements for individual construction activities are specified in the Sections that specify those activities. Those requirements, including inspections and tests, cover production of standard products as well as customized fabrication and installation procedures.
  - 2. Inspections, test and related actions specified are not intended to limit the Contractor's quality control procedures that facilitate compliance with Contract Document requirements.
  - 3. Requirements for the Contractor to provide quality control services required by the Owner, or authorities having jurisdiction are not limited by provisions of this Section.

1.02 RELATED DOCUMENTS

- A. Drawings and general provisions of Contract, including General and Supplementary Conditions and all other Divisions of the Project Manual, apply to this Section.

1.03 RESPONSIBILITIES

- A. The Contractor shall provide inspections, tests and similar quality control services, specified in individual Specification Sections and required by governing authorities, except where they are specifically indicated to be the Owner's responsibility, or are provided by another identified entity; these services include those specified to be performed by an independent agency and not by the Contractor. Costs for these services shall be included in the Contract Sum.
  - 1. The Owner will select and the Contractor shall employ and pay an independent agency, to perform specified quality control services.
    - a. Where the Owner has engaged a testing agency or other entity for testing and inspection of a part of the Work, and the Contractor is also required to engage an entity for the same or related element, the Contractor shall not employ the entity engaged by the Owner, unless otherwise agreed in writing with the Owner.
  - 2. Re-testing: The Contractor is responsible for re-testing where results of required inspections, tests or similar services prove unsatisfactory and do not indicate compliance with Contract Document requirements, regardless of whether the original test was the Contractor's responsibility.
    - a. Cost of re-testing construction revised or replaced by the Contractor is the Contractor's responsibility, where required tests were performed on original construction.
  - 3. Associated Services: The Contractor shall cooperate with agencies performing required inspections, tests and similar services and provide reasonable auxiliary services as requested. Notify the agency sufficiently in advance of operations to permit assignment of personnel. Auxiliary services required include but are not limited to:
    - a. Providing access to the Work and furnishing incidental labor and facilities necessary to facilitate inspections and tests.
    - b. Taking adequate quantities of representative samples of materials that require testing or assisting the agency in taking samples.
    - c. Providing facilities for storage and curing of test samples, and delivery of samples to testing laboratories.
    - d. Providing the agency with a preliminary design mix proposed for use for materials mixes that require control by the testing agency.

- e. Security and protection of samples and test equipment at the Project site.
    - B. Duties of the Testing Agency: The independent testing agency engaged to perform inspections, sampling and testing of materials and construction specified in individual Specification Sections shall cooperate with the Owner and Contractor in performance of its duties, and shall provide qualified personnel to perform required inspections and tests.
      - 1. The agency shall notify the Owner and Contractor promptly of irregularities or deficiencies observed in the Work during performance of its services.
      - 2. The agency is not authorized to release, revoke, alter or enlarge requirements of the Contract Documents, or approve or accept any portion of the Work.
      - 3. The agency shall not perform any duties of the Contractor.
    - C. Coordination: The Contractor and each agency engaged to perform inspections, tests and similar services shall coordinate the sequence of activities to accommodate required services with a minimum of delay. In addition the Contractor and each agency shall coordinate activities to avoid the necessity of removing and replacing construction to accommodate inspections and tests.
      - 1. The Contractor is responsible for scheduling times for inspections, tests, taking samples and similar activities.
- 1.04 SUBMITTALS
- A. The independent testing agency shall submit a certified written report of each inspection, test or similar service, to the Owner, in duplicate, and a copy to the Contractor.
    - 1. Submit additional copies of each written report directly to the governing authority, when the authority so directs.
    - 2. Report Data: Written reports of each inspection, test or similar service shall include, but not be limited to:
      - a. Date of issue.
      - b. Project title and number.
      - c. Name, address and telephone number of testing agency.
      - d. Dates and locations of samples and tests or inspections.
      - e. Names of individuals making the inspection or test.
      - f. Designation of the Work and test method.
      - g. Identification of product and Specification Section.
      - h. Complete inspection or test data.
      - i. Test results and an interpretations of test results.
      - j. Ambient conditions at the time of sample-taking and testing.
      - k. Comments or professional opinion as to whether inspected or tested Work complies with Contract Document requirements.
      - l. Name and signature of laboratory inspector.
      - m. Recommendations on re-testing.
- 1.05 QUALITY ASSURANCE
- A. Qualification for Service Agencies: Engage inspection and testing service agencies, including independent testing laboratories, which are prequalified as complying with "Recommended Requirements for Independent Laboratory Qualification" by the American Council of Independent Laboratories, and which specialize in the types of inspections and tests to be performed.
    - 1. Each independent inspection and testing agency engaged on the Project shall be authorized by authorities having jurisdiction to operate in the State of Illinois.
  - B. Meet basic requirements of ASTM E329 Standard of Recommended Practice for Inspection and Testing Agencies for Concrete and Steel Used in Construction."
  - C. Submit copy of report of inspection of facilities made by Materials Reference Laboratory of National Bureau of Standards during most recent tour of inspection; with memorandum of remedies of all deficiencies reported by inspection.
  - D. Testing Equipment:
    - 1. Calibrated at maximum 12-month intervals by devices of accuracy traceable to either:
      - a. National Bureau of Standards
      - b. Accepted values of natural physical constants.
    - 2. Submit copy of certificate of calibration, made by accredited calibration agency.
- 1.06 LABORATORY DUTIES: LIMITS OF AUTHORITY
- A. Cooperate with Owner and Contractor; provide qualified personnel promptly on notice.
  - B. Perform specified inspections, sampling and testing of materials and construction methods.

1. Comply with specified Standards: ASTM, other recognized authorities, and as specified.
  2. Ascertain compliance with Contract requirements.
  - C. Promptly notify Owner and Contractor of irregularities or deficiencies of work which are observed during performance of services.
  - D. Promptly submit 5 copies of reports of inspections and tests to Owner including:
    1. Date issued
    2. Project title and number
    3. Testing Laboratory name and address
    4. Name and signature of Inspector
    5. Date of inspection and sampling
    6. Record of temperature and weather
    7. Date of test
    8. Identification of product and Specification Section
    9. Location in project
    10. Type of inspection or test
    11. Observations regarding compliance with Contract Documents
  - E. Perform additional services as required by Owner.
  - F. Laboratory is not authorized to:
    1. Release, revoke, alter or enlarge on, Contract requirements.
    2. Approve or accept any portion of work.
    3. Perform any duties of the Contractor.
- 1.07 **CONTRACTOR'S RESPONSIBILITIES**
- A. Cooperate with Laboratory personnel, provide access to work, to manufacturer's operations.
  - B. Provide Laboratory, preliminary representative samples of materials for testing, in required quantities.
  - C. Furnish copies of mill test reports.
  - D. Furnish casual labor and facilities:
    1. To provide access to work to be tested.
    2. To obtain and handle samples at site.
    3. To facilitate inspections and tests.
    4. For Laboratory's exclusive use for storage and curing of test samples.
  - E. Notify Laboratory sufficiently in advance of operations to allow for personnel assignment of test scheduling.
  - F. Employ, and pay for, services of a separate, equally qualified, Independent Testing Laboratory to perform additional inspections, sampling and testing required.
    1. For Contractor's convenience.
    2. When initial tests indicate work does not comply with Contract.

**PART 2 - PRODUCTS  
(Not Applicable)**

**PART 3 - EXECUTION**

- 3.01 **REPAIR AND PROTECTION**
- A. General: Upon completion of inspection, testing, sample-taking and similar services, repair damaged construction and restore substrates and finishes to eliminate deficiencies, including deficiencies in visual qualities of exposed finishes. Comply with Contract Document requirements for "Cutting and Patching."
  - B. Protect construction exposed by or for quality control services, and protect repaired construction.
  - C. Repair and protection is the Contractor's responsibility, regardless of the assignment of responsibility for inspection, testing or similar services.

**END OF SECTION 01 40 00**

**SECTION 01 60 00  
MATERIALS AND EQUIPMENT**

**PART 1 - GENERAL**

1.01 SUMMARY

- A. This Section specifies administrative and procedural requirements governing the Contractor's selection of products for use in the Project.
- B. The Contractor's Construction Schedule and the Schedule of Submittals are included under Section 01 30 00 - SUBMITTALS.

1.02 RELATED DOCUMENTS

- A. Drawings and general provisions of Contract, including General and Supplementary Conditions and all other Divisions of the Project Manual, apply to this Section.

1.03 DEFINITIONS

- A. Definitions used in this Article are not intended to change the meaning of other terms used in the Contract Documents, such as "specialties," "systems," "structure," "finishes," "accessories," and similar terms. Such terms such are self-explanatory and have well recognized meanings in the construction industry.
  - 1. "Products" are items purchased for incorporation in the Work, whether purchased for the Project or taken from previously purchased stock. The term "product" includes the terms "material," "equipment," "system," and terms of similar intent.
  - 2. "Named Products" are items identified by manufacturer's product name, including make or model designation, indicated in the manufacturer's published product literature, that is current as of the date of the Contract Documents.

1.04 QUALITY ASSURANCE

- A. Source Limitations: To the fullest extent possible, provide products of the same kind, from a single source.
  - 1. When specified products are available only from sources that do not or cannot produce a quantity adequate to complete project requirements in a timely manner, consult with the Owner for a determination of the most important product qualities before proceeding. Qualities may include attributes relating to visual appearance, strength, durability, or compatibility. When a determination has been made, select products from sources that produce products that possess these qualities, to the fullest extent possible.
- B. Compatibility of Options: When the Contractor is given the option of selecting between two or more products for use on the Project, the product selected shall be compatible with products previously selected, even if previously selected products were also options.
  - 1. The Contractor is responsible for providing products and construction methods that are compatible with products and construction methods of subcontractors.
  - 2. If a dispute arises between the general Contractor and subcontractors over concurrently selectable, but incompatible products, the Owner will determine which products shall be retained and which are incompatible and must be replaced.
- C. Nameplates: Except for required labels and operating data, do not attach or imprint manufacturer's or producer's nameplates or trademarks on exposed surfaces of products which will be exposed to view.
  - 1. Labels: Locate required product labels and stamps on a concealed surface or, where required for observation after installation, on an accessible surface that is not conspicuous.
- D. Manufacturer's Instructions
  - 1. When contract documents specify that installation shall comply with manufacturer's printed instructions, obtain and distribute copies of such instructions to all parties involved in the installation, including the Owner.
  - 2. Maintain one set of complete instructions with the Project Record Documents at the job site during installation and until completion.

## 1.05 PRODUCT DELIVERY, STORAGE, AND HANDLING

- A. Deliver, store and handle products in accordance with the manufacturer's recommendations, using means and methods that will prevent damage, deterioration and loss, including theft.
  - 1. Schedule delivery to minimize long-term storage at the site and to prevent overcrowding of construction spaces.
  - 2. Coordinate delivery with installation time to ensure minimum holding time for items that are flammable, hazardous, easily damaged, or sensitive to deterioration, or theft.
  - 3. Deliver products to the site in the manufacturer's original sealed container or other packaging system, complete with labels and instructions for handling, storing, unpacking, protecting and installing.
  - 4. Inspect products upon delivery to ensure compliance with the Contract Documents, and to ensure that products are undamaged and properly protected.
  - 5. Store products at the site in a manner that will facilitate inspection and measurement of quantity or counting of units.
  - 6. Store heavy materials away from the Project structure in a manner that will not endanger the supporting construction.
  - 7. Store products subject to damage by the elements above ground, under cover in a weathertight enclosure, with ventilation adequate to prevent condensation. Maintain temperature and humidity within range required by manufacturer's instructions.
- B. Arrange for transportation and deliveries of materials and equipment in accord with approved current construction schedules and in ample time to facilitate inspection prior to installation.
- C. Coordinate deliveries to avoid conflict with work and conditions at site:
  - 1. Work of other contractors or Owner, or their use of premises.
  - 2. Limitations of storage space.
  - 3. Availability of equipment and personnel for handling products.

## PART 2 - PRODUCTS

### 2.01 PRODUCT SELECTION

- A. General Product Requirements: Provide products that comply with the Contract Documents, that are undamaged and, unless otherwise indicated, unused at the time of installation.
  - 1. Provide products complete with all accessories, trim, finish, safety guards and other devices and details needed for a complete installation and for the intended use and effect.
  - 2. Standard Products: Where available, provide standard products of types that have been produced and used successfully in similar situations on other projects.
  - 3. Comply with size, make, type and quality specified.
  - 4. Manufactured and fabricated products:
    - a. Design, fabricate and assemble in accord with best engineering and shop practices.
    - b. Manufacture like parts of duplicate units to standard interchangeable sizes.
    - c. Two or more items of the same kind shall be identical from the same manufacturer.
    - d. All system parts shall be from the same manufacturer to the greatest extent practical.
    - e. Adhere to equipment capacities, sizes and dimensions shown or specified unless variations are specifically approved by Change Order.
- B. Product Selection Procedures: Product selection is governed by the Contract Documents and governing regulations, not by previous Project experience. Procedures governing product selection include the following:
  - 1. Proprietary Specification Requirements: Where only a single product or manufacturer is named, provide the product indicated. No substitutions will be permitted.
  - 2. Semi-proprietary Specification Requirements: Where two or more products or manufacturers are named, provide one of the products indicated. No substitutions will be permitted.
    - a. Where products or manufacturers are specified by name, accompanied by the term "or equal," or "or approved equal" comply with the Contract's provisions concerning "substitutions" to obtain approval for use of an unnamed product.

3. Non-Proprietary Specifications: When the Specifications list products or manufacturers that are available and may be incorporated in the Work, but do not restrict the Contractor to use of these products only, the Contractor may propose any available product that complies with Contract requirements. Comply with Contract Document provisions concerning "substitutions" to obtain approval for use of an unnamed product.
  4. Descriptive Specification Requirements: Where Specifications describe a product or assembly, listing exact characteristics required, with or without use of a brand or trade name, provide a product or assembly that provides the characteristics and otherwise complies with Contract requirements.
  5. Performance Specification Requirements: Where Specifications require compliance with performance requirements, provide products that comply with these requirements, and are recommended by the manufacturer for the application indicated. General overall performance of a product is implied where the product is specified for a specific application.
    - a. Manufacturer's recommendations may be contained in published product literature, or by the manufacturer's certification of performance.
  6. Compliance with Standards, Codes and Regulations: Where the Specifications only require compliance with an imposed code, standard or regulation, select a product that complies with the standards, codes or regulations specified.
  7. Visual Matching: Where Specifications require matching an established Sample, the Owner's decision will be final on whether a proposed product matches satisfactorily.
    - a. Where no product available within the specified category matches satisfactorily and also complies with other specified requirements, comply with provisions of the Contract Documents concerning "substitutions" for selection of a matching product in another product category, or for noncompliance with specified requirements.
  8. Visual Selection: Where specified product requirements include the phrase "...as selected from manufacturer's standard colors, patterns, textures..." or a similar phrase, select a product and manufacturer that complies with other specified requirements. The Owner will select the color, pattern and texture from the product line selected.
- C. Deliver products in undamaged condition in original containers or packaging, with identifying labels intact and legible.
  - D. Clearly mark partial deliveries of component parts or assemblies or equipment to permit easy identification of parts and to facilitate assembly.
  - E. Immediately on delivery, inspect shipment to assure:
    1. Product complies with contract documents and Owner
    2. Quantities are correct.
    3. Containers and packages are intact and labels are legible.
    4. Products are properly protected and undamaged.

### **PART 3 - EXECUTION**

#### **3.01 INSTALLATION OF PRODUCTS:**

- A. Comply with manufacturer's instructions and recommendations for installation of products in the applications indicated. Anchor each product securely in place, accurately located and aligned with other Work.
  1. Clean exposed surfaces and protect as necessary to ensure freedom from damage and deterioration at time of Substantial Completion.
- B. Provide equipment and personnel to handle products and equipment, including those furnished by the Owner. Prevent damage to products or packaging.
- C. Provide additional protection during handling to prevent scraping, marring or otherwise damaging products, equipment or surrounding surfaces.
- D. Handle products and equipment in manner to prevent bending or overstressing.
- E. Lift packages, equipment or components only at designated lift points.

**END OF SECTION 01 60 00**

**SECTION 01 63 00  
SUBSTITUTIONS AND PRODUCT OPTIONS**

**PART 1 - GENERAL**

1.01 WORK INCLUDES

- A. Base all bids on providing all products exactly as specified.
- B. For products specified only by reference or performance standards, select any product which meets or exceeds standards, by any manufacturer, subject to the Owner's approval.
- C. For products specified by naming several products or manufacturers, select any product and manufacturer named.

1.02 RELATED WORK

- A. Drawings and general provisions of Contract, including General and Supplementary Conditions, Special Provisions and all other Divisions of the Project Manual, apply to this Section.

1.03 SUBSTITUTIONS, BIDDER/CONTRACTOR OPTIONS

- A. Prior to Bid Opening: The Owner will consider written requests to amend the bidding documents to add products not specified provided such requests are received at least 10 calendar days prior to bid opening date. Requests received after that time will not be considered. When a request is approved, the Owner will issue an appropriate addendum not less than three (3) calendar days prior to bid opening date.
- B. With Bid: A bidder may propose substitutions with his bid by completing the Product Substitution List in the Bid Form, subject to the provisions stated thereon. The Owner will review Proposed Product Substitution List of low bidder and recommend approval or rejection by the Owner prior to award of contract.
- C. After Award of Contract: No substitutions will be considered after Notice of Award except under one or more of the following conditions:
  - 1. Substitution required for compliance with final interpretations of code requirement or insurance regulations.
  - 2. Unavailability of specified products, through no fault of the Contractor.
  - 3. Subsequent information discloses inability of specified product to perform properly or to fit in designated space.
  - 4. Manufacturer/fabricator refusal to certify or guarantee performance of specified product as specified.
  - 5. When a substitution would be substantially to Owner's best interest.

1.04 SUBSTITUTION REQUIREMENTS

- A. Submit three (3) copies of each request for substitution. Include in request:
  - 1. Complete data substantiating compliance of proposed substitution with contract documents.
  - 2. For products:
    - a. Product identification, including manufacturer's name and address.
    - b. Manufacturer's literature:
      - 1) Product description
      - 2) Performance and test data
      - 3) Reference standards
    - c. Samples
    - d. Name and address of similar projects on which product was used and dates of installation.
  - 3. For construction methods:
    - a. Detailed description of proposed method.
    - b. Drawings illustrating methods.
  - 4. Itemized comparison of proposed substitution with product or method specified.
  - 5. Data relating to changes in construction schedule.
  - 6. Identify:
    - a. Changes or coordination required.
    - b. Other contracts affected.
  - 7. Accurate cost data on proposed substitution in comparison with product or method specified.
- B. In making request for substitution, bidder/contractor represents:

1. He has personally investigated proposed product or method and determined that it is equal or superior in all respects to that specified.
  2. He will provide the same guarantee for substitution as for product or method specified.
  3. He will coordinate installation of accepted substitutions into the work, making all changes for work to be complete in all respects.
  4. Cost data is complete and includes all related costs under his contract, but excludes:
    - a. Owner's redesign.
    - b. Administrative costs of Owner.
    - c. Costs under separate contracts.
  5. He will pay all additional costs and expenses for Owner and other contractors.
- C. Substitutions will not be considered when:
1. They are indicated or implied on shop drawings or product data submittals without formal request submitted in accordance with this Section.
  2. Acceptance will require substantial revision of contract documents.

**PART 2 – PRODUCTS  
(NOT APPLICABLE)**

**PART 3 – EXECUTION  
(NOT APPLICABLE)**

**END OF SECTION 01 63 00**

**SECTION 01 70 00  
PROJECT CLOSEOUT**

**PART 1 - GENERAL**

1.01 WORK INCLUDES

- A. Substantial completion, final completion, closeout submittals, and application for final payment.
- B. This Section specifies administrative and procedural requirements for project closeout, including but not limited to:
  - 1. Inspection procedures.
  - 2. Project record document submittal.
  - 3. Operating and maintenance manual submittal.
  - 4. Submittal of warranties.
  - 5. Final cleaning.
  - 6. Final payment.

1.02 RELATED WORK

- A. Drawings and general provisions of Contract, including General and Supplementary Conditions and all other Divisions of the Project Manual, apply to this Section.

1.03 SUBSTANTIAL COMPLETION

- A. When the Contractor considers the work substantially complete, Contractor shall submit written declaration to the Owner that the work, or designated portion thereof, is substantially complete. Include list of items to be completed or corrected.
- B. Owner and Contractor will make an inspection within seven days after receipt of certification.
- C. Should the Owner consider that the work is substantially complete:
  - 1. The Owner will prepare and issue a Certificate of Substantial Completion, containing:
    - a. Date of Substantial Completion.
    - b. Punch list of items to be completed or corrected.
    - c. The time within which Contractor shall complete or correct work of listed items. All punch list items must be completed within 30 days of substantial completion.
    - d. Date and time Owner will assume possession of work or designated portion thereof.
    - e. Responsibilities of Owner and Contractor for:
      - (1.) Insurance
      - (2.) Utilities
      - (3.) Operation of mechanical, electrical and other systems.
      - (4.) Maintenance and cleaning.
      - (5.) Security
    - f. Signatures of Owner and Contractor
- D. Should the Owner consider that work is not substantially completed:
  - 1. The Owner shall immediately notify Contractor, in writing, stating reasons.
  - 2. The Contractor shall complete work and send a second written notice to Owner, certifying that project, or designated portion of project, is substantially complete.
  - 3. The Owner will re-inspect work.

1.04 FINAL INSPECTION

- A. When the Contractor considers the work complete, the Contractor shall submit written declaration to the Owner that the work is complete. Contractor shall submit written certification that:
  - 1. Contract documents have been reviewed.
  - 2. Project has been inspected for compliance with contract.
  - 3. Work has been completed in accord with contract.
  - 4. Equipment and systems have been tested in the Owner's presence and are operational.
  - 5. Project is completed, ready for final inspection.
- B. The Owner will make final inspection within seven days after receipt of certification.
- C. Should the Owner consider that work is finally complete in accord with Contract Document requirements, he shall request contractor to make project closeout submittals.
- D. Should the Owner consider that work is not finally complete:
  - 1. The Owner shall notify the Contractor, in writing, stating reasons.

2. The Contractor shall take immediate steps to remedy the stated deficiencies, and send second written notice to the Owner certifying that the work is complete.
  3. The Owner will re-inspect work.
- 1.06 CLOSEOUT SUBMITTALS
- A. Project Record Documents: In accordance with requirements of SECTION 01 72 00 - PROJECT RECORD DOCUMENTS.
  - B. Deliver evidence of compliance with requirements of governing authorities.
  - C. Deliver Certificate of Insurance for products and completed operations. Certificate shall include a evidence that insurance required by the Contract Documents to remain in force after final payment is currently in effect and will not be canceled or allowed to expire until at least 30 days prior notice has been given to the Contractor. Contractor shall include a written statement that Contractor knows of no substantial reason that the insurance will not be renewable to cover the period required by the Contract Documents.
  - D. Evidence of payments, release of liens
    1. Consent of Surety to Final Payment.
    2. Other data establishing payment or satisfaction of obligations including receipts, Contractor's releases and waivers of liens, claims, security interests or encumbrances arising out of the Contract, to the extent and form as required by the City.
    3. Separate releases of waivers of liens for subcontractors, suppliers and others with lien rights against property of Owner together with list of those parties.
    4. Paid utility bills, if any.
    5. An affidavit that payrolls, bills for materials and equipment and other indebtedness connected to the work for which the City or the City's property might be responsible or encumbered (less any amounts withheld by City) have been paid or otherwise satisfied.
- 1.07 INSTRUCTION
- A. Instruct Owner's personnel in operation of all systems, mechanical, electrical and other equipment.
- 1.08 FINAL ADJUSTMENT OF ACCOUNTS
- A. Submit final statement of accounting to Owner.
  - B. Statement shall reflect all adjustments.
    1. Original contract sum.
    2. Additions and deductions resulting from:
      - a. Previous change orders.
      - b. Cash allowances.
      - c. Unit prices.
      - d. Other adjustments.
      - e. Deductions for uncorrected work.
      - f. Deductions for re-inspection payments.
    3. Total contract sum, as adjusted.
    4. Previous payments.
    5. Sum remaining due.
  - C. The Owner will prepare final change order, reflecting approved adjustments to contract sum not previously made by change orders.
- 1.09 FINAL APPLICATION FOR PAYMENT
- A. Contractor shall submit final application in accord with requirements of Conditions of Contract.
- 1.10 FINAL CERTIFICATE FOR PAYMENT
- A. The Owner will issue final certificate in accord with provisions of Conditions of contract.
  - B. Should final completion be materially delayed through no fault of the Contractor, the Owner may issue a Semi-Final Certificate of Payment, in accord with provisions of Conditions of Contract.

**PART 2 – PRODUCTS  
(NOT APPLICABLE)**

**PART 3 – EXECUTION  
(NOT APPLICABLE)**

**END OF SECTION 01 70 00**

**SECTION 01 71 00  
CLEANING**

**PART 1 - GENERAL**

- 1.01 WORK INCLUDES
- A. Contractor shall maintain premises and public properties free from accumulations of waste, debris, and rubbish, caused by construction operations.
  - B. At completion of work, Contractor shall remove waste materials, rubbish, tools, equipment, machinery and surplus materials, clean all sight-exposed surfaces and leave project clean and ready for occupancy.
- 1.02 RELATED WORK
- A. Drawings and general provisions of Contract, including General and Supplementary Conditions and all other Divisions of the Project Manual, apply to this Section.
- 1.03 SAFETY REQUIREMENTS
- A. Standards: Maintain project in accord with following safety and insurance standards.
    - 1. Occupational Safety and Health Administration (OSHA).
  - B. Hazards Control:
    - 1. Store volatile wastes in covered metal containers and remove from premises daily.
    - 2. Prevent accumulation of wastes which create hazardous conditions.
    - 3. Provide adequate ventilation during use of volatile or noxious substances.
  - C. Conduct cleaning and disposal operations to comply with Federal, State and local ordinances and anti-pollution laws.
    - 1. Do not burn or bury debris, rubbish or other waste materials on project site.
    - 2. Do not dispose of volatile wastes such as mineral spirits, oil or paint thinner in storm or sanitary drains.
    - 3. Do not dispose of wastes into streams or waterways.

**PART 2 - PRODUCTS**

- 2.01 MATERIALS
- A. Select and use all cleaning materials and equipment with care to avoid scratching, marring, defacing, staining or discoloring surfaces cleaned.
  - B. Use only cleaning materials recommended by manufacturer of surface to be cleaned.
  - C. Use cleaning materials only on surfaces recommended by cleaning material manufacturer.

**PART 3 - EXECUTION**

- 3.01 DURING CONSTRUCTION
- A. Execute cleaning to ensure that grounds and public properties are maintained free from accumulations of waste materials and rubbish.
  - B. Wet down materials and rubbish to lay dust and to prevent blowing dust.
  - C. At reasonable intervals during progress of work, clean site and public properties, and dispose of waste materials, debris and rubbish.
  - D. Provide on-site metal containers for collection of waste materials, debris and rubbish.
  - E. Remove waste materials, debris and rubbish from site and legally dispose of at public or private dumping areas off Owner's property.
  - F. Handle waste materials in a controlled manner with as few handlings as possible; do not drop or throw materials from heights.
  - G. Schedule cleaning operations so that dust and other contaminants resulting from cleaning process will not fall on wet, newly painted surfaces.
- 3.02 FINAL CLEANING
- A. General: Provide final cleaning operations when indicated. Employ experienced workers or professional cleaners for final cleaning. Clean each surface or unit of Work to the condition expected from a commercial building cleaning and maintenance program. Comply with manufacturer's instructions.
  - B. In preparation for substantial completion or occupancy, conduct final inspection of sight-exposed interior and exterior surfaces, and of concealed spaces.

- C. Clean the Project site, yard and grounds, in areas disturbed by construction activities, including landscape development areas, of rubbish, waste materials, litter and foreign substances. Sweep paved areas broom clean. Remove petro-chemical spills, stains and other foreign deposits. Rake grounds that are neither planted nor paved, to a smooth even-textured surface.
  - 1. Remove tools, construction equipment, machinery and surplus material from the site.
  - 2. Clean exposed exterior hard-surfaced finishes to a dirt-free condition, free of stains, films and similar foreign substances. Avoid disturbing natural weathering of exterior surfaces. Restore reflective surfaces to their original condition.
  - 3. Remove debris and surface dust from limited access spaces.
  - 4. Remove labels that are not permanent labels.
  - 5. Touch-up and otherwise repair and restore marred exposed finishes and surfaces. Replace finishes and surfaces that can not be satisfactorily repaired or restored, or that show evidence of repair or restoration. Do not paint over "UL" and similar labels, including mechanical and electrical name plates.
  - 6. Clean plumbing fixtures to a sanitary condition, free of stains, including stains resulting from water exposure.
  - 7. Leave the Project clean and ready for occupancy.
- E. Repair, patch and touch up marred surfaces to specified finish, to match adjacent surfaces.
- F. Broom clean paved surfaces; rake clean other surfaces on grounds.
- G. Maintain cleaning until project, or designated portion thereof, is occupied by Owner.

**END OF SECTION 01 71 00**

**SECTION 01 73 00  
OPERATING AND MAINTENANCE DATA**

**PART 1 - GENERAL**

- 1.01 WORK INCLUDES
- A. Contractor shall:
1. Compile product data and related information appropriate for Owner's maintenance and operation of products and equipment provided under the Contract.
  2. Instruct Owner's personnel in operation and maintenance of products, equipment and systems.
- 1.02 RELATED REQUIREMENTS
- A. Drawings and general provisions of Contract, including General and Supplementary Conditions and all other Divisions of the Project Manual, apply to this Section.
- 1.03 QUALITY ASSURANCE
- A. Maintenance Manual Preparation: In preparation of Maintenance Manuals, use personnel thoroughly trained and experienced in operation and maintenance of the equipment or system involved.
1. Where written instructions are required, use personnel skilled in technical writing to the extent necessary for communication of essential data.
  2. Where Drawings or diagrams are required, use draftsmen capable of preparing Drawings clearly in an understandable format.
- B. Instructions for the Owner's Personnel: For instruction of the Owner's operating and maintenance personnel, use experienced instructors thoroughly trained and experienced in the operation and maintenance of the equipment or system involved.
- 1.04 SUBMITTALS
- A. Form: Manufacturer's standard product or equipment data of same type and form furnished to manufacturer's maintenance personnel.
- B. Provide sturdy manila or kraft envelope, properly labelled, of sufficient size to contain all submittals.
- C. Submit one copy of data in final form at least fifteen days before final inspection. This copy will be returned within fifteen days after final inspection, with comments.
1. After final inspection make corrections or modifications to comply with the Owner's comments. Submit the specified number of copies of each approved manual to the Owner within fifteen days of receipt of the Owner's comments.
- D. Form of Submittal: Prepare operating and maintenance manuals in the form of an instructional manual for use by the Owner's operating personnel. Organize into suitable sets of manageable size. Where possible, assemble instructions for similar equipment into a single binder.
- E. Binders: For each manual, provide heavy-duty, commercial quality, durable 3-ring vinyl covered loose-leaf binders, in thickness necessary to accommodate contents, sized to receive 8-1/2" by 11" paper. Provide a clear plastic sleeve on the spine, to hold labels describing the contents. Provide pockets in the covers to receive folded sheets.
- F. Text Material: Where written material is required as part of the manual use the manufacturer's standard printed material, or if it is not available, specially prepared data, neatly typewritten, on 8-1/2" by 11", 20 pound white bond paper.
- G. Drawings: Where drawings or diagrams are required as part of the manual, provide reinforced punched binder tabs on the drawings and bind in with the text.
- 1.04 MANUAL CONTENT
- A. Neatly typewritten table of contents for each volume, arranged in systematic order. Follow Project Manual format.
- B. In each manual include information specified in the individual Specification Section, and the following information for each major component of equipment and its controls:
1. General system or equipment description.
  2. Design factors and assumptions.
  3. Copies of applicable Shop Drawings and Product Data.
  4. System or equipment identification, including:
    - a. Name of manufacturer.
    - b. Model number.

- c. Serial number of each component.
  5. Operating instructions.
  6. Emergency instructions.
  7. Wiring diagrams.
  8. Inspection and test procedures.
  9. Maintenance procedures and schedules.
  10. Precautions against improper use and maintenance.
  11. Copies of warranties.
  12. Repair instructions including spare parts listing.
  13. Sources of required maintenance materials and related services.
  14. Manual Index.
  15. Contractor, name of responsible principal, address and telephone number
  16. List with each product, the name, address and telephone number of:
    - a. Subcontractor
    - b. Maintenance contractor, as appropriate.
    - c. Identify area of responsibility of each
    - d. Local supply source for parts and replacement.
- C. Organize each manual into separate Sections for each piece of related equipment. As a minimum each manual shall contain a title page, a table of contents, copies of Product Data, supplemented by drawings and written text, and copies of each warranty, bond and service Contract issued.
- D. General Information: Provide a general information Section immediately following the Table of Contents, listing each product included in the manual, identified by product name. Under each product, list the name, address, and telephone number of the Subcontractor or installer, and the maintenance contractor. Clearly delineate the extent of responsibility of each of these entities. In addition, list a local source for replacement parts and equipment.
- E. Product Data: Where manufacturer's standard printed data is included in the manuals, include only sheets that are pertinent to the part or product installed. Mark each sheet to identify each part or product included in the installation. Where more than one item in a tabular format is included, identify each item, using appropriate references from the Contract Documents. Identify data that is applicable to the installation and delete references to information that is not applicable.
- F. Written Text: Where manufacturer's standard printed data is not available, and information is necessary for proper operation and maintenance of equipment or systems, or it is necessary to provide additional information to supplement data included in the manual, prepare written text to provide necessary information. Organize the text in a consistent format under separate headings for different procedures. Where necessary, provide a logical sequence of instruction for each operating or maintenance procedure.
- G. Drawings: Provide specially prepared drawings where necessary to supplement manufacturer's printed data to illustrate the relationship of component parts of equipment or systems, or to provide control or flow diagrams. Coordinate these drawings with information contained in Project Record Drawings to assure correct illustration of the completed installation.
- H. Do not use original Project Record Documents as part of the Operating and Maintenance Manuals.
- I. Warranties, Bonds and Service Contracts: Provide a copy of each warranty, bond or service contract in the appropriate manual for the information of the Owner's operating personnel. Provide written data outlining procedures to be followed in the event of product failure. List circumstances and conditions that would affect validity of the warranty or bond.
  1. Contractor, name of responsible principal, address and telephone number.
  2. List of each product specified to be included, indexed to volume content.
  3. List with each product, the name, address and telephone number of:
    - a. Subcontractor.
    - b. Maintenance contractor, as appropriate.
    - c. Identify area of responsibility of each.
    - d. Local supply source for parts and replacement.
- J. Product Data:
  1. Include only sheets pertinent to specific product.
  2. Annotate each sheet to:
    - a. Clearly identify specific product or part installed.
    - b. Clearly identify data applicable to installation.
    - c. Delete references to inapplicable installation.

- K. Drawings:
    - 1. Supplement product data with drawings to clearly illustrate relationship of component parts of equipment and systems and control and flow diagrams.
    - 2. Coordinate drawings with information in Product Record Documents to assure correct illustration of completed installation.
    - 3. Do not use Project Record Documents as maintenance drawings.
  - L. Written text to supplement product data for particular installation:
    - 1. Organize in consistent format under separate headings for different procedures.
    - 2. Provide logical sequence of instructions for each procedure.
  - M. Copy of each warranty, bond and service contract issued.
    - 1. Provide information sheet for Owner personnel. Give:
      - a. Proper procedures in event of failure.
      - b. Instances which might affect validity of warranties or bonds.
- 1.05 MANUAL FOR MATERIALS AND FINISHES
- A. Submit two (2) copies of complete manual in final form.
  - B. Refer to individual Specification Sections for additional requirements on care and maintenance of materials and finishes.
  - C. Content for products, applied materials and finishes:
    - 1. Manufacturer's data, giving full information on products.
      - a. Catalog number, size, composition.
      - b. Color and texture designations.
      - c. Information for re-ordering special-manufactured products.
    - 2. Instructions for care and maintenance.
      - a. Manufacturer's recommendations for types of cleaning agents and methods.
      - b. Cautions against cleaning agents and methods detrimental to product.
      - c. Recommended cleaning and maintenance schedule.
  - D. Moisture-Protection and Weather-Exposed Products: Provide complete manufacturer's data with instructions on inspection, maintenance and repair of products exposed to the weather or designed for moisture-protection purposes.
  - E. Manufacturer's Data: Provide manufacturer's data giving detailed information, including the following, as applicable:
    - 1. Applicable standards.
    - 2. Chemical composition.
    - 3. Installation details.
    - 4. Inspection procedures.
    - 5. Maintenance information.
    - 6. Repair procedures.

**PART 2 - PRODUCTS  
(NOT APPLICABLE)**

**PART 3 - EXECUTION  
(NOT APPLICABLE)**

**END OF SECTION 01 73 00**

**SECTION 01 74 00  
WARRANTIES AND BONDS**

**PART 1 - GENERAL**

1.01 SUMMARY

- A. This Section specifies general administrative and procedural requirements for warranties and bonds required by the Contract Documents, including manufacturer's standard warranties on products and special warranties.
  - 1. Warranties for the Work and products and installations of each Contractor shall be one (1) year unless specified otherwise on the Drawings or in the individual Sections of Divisions 2 through 16.
- B. Disclaimers and Limitations: Manufacturer's disclaimers and limitations on product warranties do not relieve the Contractor of the warranty on the Work that incorporates the products, nor does it relieve suppliers, manufacturers, and Contractors required to countersign special warranties with the Contractor.

1.02 RELATED DOCUMENTS

- A. Drawings and general provisions of Contract, including General and Supplementary Conditions and all other Divisions of the Project Manual, apply to this Section.

1.03 WARRANTY REQUIREMENTS

- A. Related Damages and Losses: When correcting warranted Work that has failed, remove and replace other Work that has been damaged as a result of such failure or that must be removed and replaced to provide access for correction of warranted Work.
- B. Reinstatement of Warranty: When Work covered by a warranty has failed and been corrected by replacement or rebuilding, reinstate the warranty by written endorsement. The reinstated warranty shall be equal to the original warranty with an equitable adjustment for depreciation.
- C. Replacement cost: Upon determination that Work covered by a warranty has failed, replace or rebuild the Work to an acceptable condition complying with requires of the Contract Documents. The Contractor is responsible for the cost of replacing or rebuilding defective Work regardless of whether the Owner has benefited from use of the Work through a portion of its anticipated useful service life.
- D. Owner's Recourse: Written warranties made to the Owner are in addition to implied warranties, and shall limit the duties, obligations, rights and remedies otherwise available under the law, nor shall warranty periods be interpreted as limitations on time in which the Owner can enforce such other duties, obligations, rights or remedies.
  - 1. Rejection of Warranties: The Owner reserves the rights to reject warranties and to limit selections to products with warranties not in conflict with requirements of the Contract Documents.
- E. The Owner reserves the right to refuse to accept Work for the Project where a special warranty, certification, or similar commitment is required on such Work or part of the Work, until evidence is presented that entities required to countersign such commitments are willing to do so.
- F. For specific warranty requirements related to landscape materials, refer to the applicable Section.

1.04 SUBMITTALS

- A. Submit written warranties to the Owner prior to the date certified for Substantial Completion. If the Owner's Certificate of Substantial Completion designates a commencement date for warranties other than the date of Substantial Completion for the Work, or a designated portion of the Work, submit written warranties upon request of the Owner.
  - 1. When a designated portion of the Work is completed and occupied or used by the Owner, by separate agreement with the Contractor during the construction period, submit properly executed warranties to the Owner within fifteen days of completion of that designated portion of the Work.

- B. Form of Submittal: At Final Completion, compile two copies of each required warranty and bond properly executed by the Contractor, or by the Contractor, Subcontractor, supplier, or manufacturer. Organize the warranty documents into an orderly sequence based on the table of contents of the Project Manual.
- C. Bind warranties and bonds in heavy-duty, commercial quality, durable 3-ring vinyl covered loose-leaf binders, thickness as necessary to accommodate contents, and sized to receive 8-1/2" by 11" paper.
  - 1. Provide heavy paper dividers with celluloid covered tabs for each separate warranty. Mark the tab to identify the product or installation. Provide a typed description of the product or installation, including the name of the product, and the name, address and telephone number of the installer.
  - 2. Identify each binder on the front and the spine with the typed or printed title "WARRANTIES AND BONDS", the project title or name, and the name of the Contractor.
  - 3. When operating and maintenance manuals are required for warranted construction, provide additional copies of each required warranty, as necessary, for inclusion in each required manual.

**PART 2 - PRODUCTS  
(NOT APPLICABLE)**

**PART 3 - EXECUTION  
(NOT APPLICABLE)**

**END OF SECTION 01 74 00**

**SECTION 024119  
SELECTIVE DEMOLITION**

**PART 1 - GENERAL**

**1.1 RELATED DOCUMENTS**

- A. Drawings and general provisions of the Contract, including General and Supplementary Conditions and Division 01 Specification Sections, apply to this Section.

**1.2 SUMMARY**

Removal of existing gas range, exhaust hood, cabinets, countertops, and ceramic floor and wall tile. Cap gas lines and patch substrates.

**A. Section Includes:**

- 1. Demolition and removal of selected portions of building or structure.
- 2. Demolition and removal of selected site elements.
- 3. Salvage of existing items to be reused or recycled.

**B. Related Requirements:**

- 1. Section 011000 "Summary" for restrictions on use of the premises, Owner-occupancy requirements, and phasing requirements.
- 2. Section 017300 "Execution" for cutting and patching procedures.
- 3. Section 013516 "Alteration Project Procedures" for general protection and work procedures for alteration projects.

**1.3 DEFINITIONS**

- A. Remove: Detach items from existing construction and dispose of them off-site unless indicated to be salvaged or reinstalled.
- B. Remove and Salvage: Detach items from existing construction, in a manner to prevent damage, and Contractor to store and reinstall.
- C. Remove and Reinstall: Detach items from existing construction, in a manner to prevent damage, prepare for reuse, and reinstall where indicated.
- D. Existing to Remain: Leave existing items that are not to be removed and that are not otherwise indicated to be salvaged or reinstalled.
- E. Dismantle: To remove by disassembling or detaching an item from a surface, using gentle methods and equipment to prevent damage to the item and surfaces; disposing of items unless indicated to be salvaged or reinstalled.

#### 1.4 MATERIALS OWNERSHIP

- A. Unless otherwise indicated, demolition waste becomes property of Contractor.
- B. Historic items, relics, antiques, and similar objects including, but not limited to, cornerstones and their contents, commemorative plaques and tablets, and other items of interest or value to Owner that may be uncovered during demolition remain the property of Owner.
  - 1. Carefully salvage in a manner to prevent damage and promptly return to Owner.

#### 1.5 PREINSTALLATION MEETINGS

- A. Pre-demolition Conference: Conduct conference at Project site.
  - 1. Inspect and discuss condition of construction to be selectively demolished.
  - 2. Review structural load limitations of existing structure.
  - 3. Review and finalize selective demolition schedule and verify availability of materials, demolition personnel, equipment, and facilities needed to make progress and avoid delays.
  - 4. Review requirements of work performed by other trades that rely on substrates exposed by selective demolition operations.
  - 5. Review areas where existing construction is to remain and requires protection.

#### 1.6 INFORMATIONAL SUBMITTALS

- A. Schedule of Selective Demolition Activities: Indicate the following:
  - 1. Detailed sequence of selective demolition and removal work, with starting and ending dates for each activity. Ensure Owner's on-site operations are uninterrupted.
  - 2. Interruption of utility services. Indicate how long utility services will be interrupted.
  - 3. Coordination for shutoff, capping, and continuation of utility services.
  - 4. Coordination of Owner's continuing occupancy of portions of existing building and of Owner's partial occupancy of completed Work.

#### 1.7 FIELD CONDITIONS

- A. Owner will occupy portions of building immediately adjacent to selective demolition area. Conduct selective demolition so Owner's operations will not be disrupted.
- B. Conditions existing at time of inspection for bidding purpose will be maintained by Owner as far as practical.
  - 1. Before selective demolition, Owner will remove the following items:
    - a. Womens Room lavatory
    - b. Wall-mounted toilets (if replacing wall material requires removal)

- C. Notify Architect of discrepancies between existing conditions and Drawings before proceeding with selective demolition.
- D. Hazardous Materials: It is not expected that hazardous materials will be encountered in the Work.
  - 1. Hazardous materials will be removed by Owner before start of the Work.
  - 2. If suspected hazardous materials are encountered, do not disturb; immediately notify Architect and Owner. Hazardous materials will be removed by Owner under a separate contract.
- E. Utility Service: Maintain existing utilities indicated to remain in service and protect them against damage during selective demolition operations.

## 1.8 WARRANTY

- A. Existing Warranties: Remove, replace, patch, and repair materials and surfaces cut or damaged during selective demolition, by methods and with materials and using approved contractors so as not to void existing warranties. Notify warrantor before proceeding. Existing warranties include the following:
  - 1. Roof
- B. Notify warrantor on completion of selective demolition, and obtain documentation verifying that existing system has been inspected and warranty remains in effect. Submit documentation at Project closeout.

## 1.9 COORDINATION

- A. Arrange selective demolition schedule so as not to interfere with Owner's operations.

## PART 2 - PRODUCTS

### 2.1 PERFORMANCE REQUIREMENTS

- A. Regulatory Requirements: Comply with governing EPA notification regulations before beginning selective demolition. Comply with hauling and disposal regulations of authorities having jurisdiction.
- B. Standards: Comply with ASSE A10.6 and NFPA 241.

## PART 3 - EXECUTION

### 3.1 EXAMINATION

- A. Verify that utilities have been disconnected and capped before starting selective demolition operations.

### 3.2 UTILITY SERVICES AND MECHANICAL/ELECTRICAL SYSTEMS

- A. Existing Services/Systems to Remain: Maintain services/systems indicated to remain and protect them against damage.
- B. Existing Services/Systems to Be Removed, Relocated, or Abandoned: Locate, identify, disconnect, and seal or cap off utility services and mechanical/electrical systems serving areas to be selectively demolished.
  - 1. Owner will arrange to shut off indicated services/systems when requested by Contractor.
  - 2. Arrange to shut off utilities with utility companies.
  - 3. If services/systems are required to be removed, relocated, or abandoned, provide temporary services/systems that bypass area of selective demolition and that maintain continuity of services/systems to other parts of building.
  - 4. Disconnect, demolish, and remove fire-suppression systems, plumbing, and HVAC systems, equipment, and components indicated on Drawings to be removed.
    - a. Piping to Be Removed: Remove portion of piping indicated to be removed and cap or plug remaining piping with same or compatible piping material.
    - b. Piping to Be Abandoned in Place: Drain piping and cap or plug piping with same or compatible piping material and leave in place.
    - c. Equipment to Be Removed: Disconnect and cap services and remove equipment.
    - d. Equipment to Be Removed and Reinstalled: Disconnect and cap services and remove, clean, and store equipment; when appropriate, reinstall, reconnect, and make equipment operational.
    - e. Equipment to Be Removed and Salvaged: Disconnect and cap services and remove equipment and deliver to Owner.
    - f. Ducts to Be Removed: Remove portion of ducts indicated to be removed and plug remaining ducts with same or compatible ductwork material.
    - g. Ducts to Be Abandoned in Place: Cap or plug ducts with same or compatible ductwork material and leave in place.

### 3.3 PROTECTION

- A. Temporary Protection: Provide temporary barricades and other protection required to prevent injury to people and damage to adjacent buildings and facilities to remain.
  - 1. Provide protection to ensure safe passage of people around selective demolition area and to and from occupied portions of building.

2. Provide temporary weather protection, during interval between selective demolition of existing construction on exterior surfaces and new construction, to prevent water leakage and damage to structure and interior areas.
  3. Protect walls, ceilings, floors, and other existing finish work that are to remain or that are exposed during selective demolition operations.
- B. Temporary Shoring: Design, provide, and maintain shoring, bracing, and structural supports as required to preserve stability and prevent movement, settlement, or collapse of construction and finishes to remain, and to prevent unexpected or uncontrolled movement or collapse of construction being demolished.
1. Strengthen or add new supports when required during progress of selective demolition.
- C. Remove temporary barricades and protections where hazards no longer exist.
- 3.4 SELECTIVE DEMOLITION, GENERAL
- A. General: Demolish and remove existing construction only to the extent required by new construction and as indicated. Use methods required to complete the Work within limitations of governing regulations and as follows:
1. Neatly cut openings and holes plumb, square, and true to dimensions required. Use cutting methods least likely to damage construction to remain or adjoining construction. Use hand tools or small power tools designed for sawing or grinding, not hammering and chopping. Temporarily cover openings to remain.
  2. Cut or drill from the exposed or finished side into concealed surfaces to avoid marring existing finished surfaces.
  3. Do not use cutting torches until work area is cleared of flammable materials. At concealed spaces, such as duct and pipe interiors, verify condition and contents of hidden space before starting flame-cutting operations. Maintain portable fire-suppression devices during flame-cutting operations.
  4. Maintain adequate ventilation when using cutting torches.
  5. Remove decayed, vermin-infested, or otherwise dangerous or unsuitable materials and promptly dispose of off-site.
  6. Dispose of demolished items and materials promptly.
- B. Site Access and Temporary Controls: Conduct selective demolition and debris-removal operations to ensure minimum interference with roads, streets, walks, walkways, and other adjacent occupied and used facilities.
- C. Removed and Reinstalled Items:
1. Clean and repair items to functional condition adequate for intended reuse.
  2. Pack or crate items after cleaning and repairing. Identify contents of containers.
  3. Protect items from damage during transport and storage.
  4. Reinstall items in locations indicated. Comply with installation requirements for new materials and equipment. Provide connections, supports, and miscellaneous materials necessary to make item functional for use indicated.

- D. Existing Items to Remain: Protect construction indicated to remain against damage and soiling during selective demolition. When permitted by Architect, items may be removed to a suitable, protected storage location during selective demolition and reinstalled in their original locations after selective demolition operations are complete.

### 3.5 DISPOSAL OF DEMOLISHED MATERIALS

- A. Remove demolition waste materials from Project site and dispose of them in an EPA-approved construction and demolition waste landfill acceptable to authorities having jurisdiction.
  - 1. Do not allow demolished materials to accumulate on-site.
  - 2. Remove and transport debris in a manner that will prevent spillage on adjacent surfaces and areas.
  - 3. Remove debris from elevated portions of building by chute, hoist, or other device that will convey debris to grade level in a controlled descent.
- B. Burning: Do not burn demolished materials.

### 3.6 CLEANING

- A. Clean adjacent structures and improvements of dust, dirt, and debris caused by selective demolition operations. Return adjacent areas to condition existing before selective demolition operations began.

END OF SECTION 024119

# LEVY SENIOR CENTER - KITCHEN INTERIOR REMODEL

300 DODGE AVE, EVANSTON, IL 60201  
(BID #26-XX)

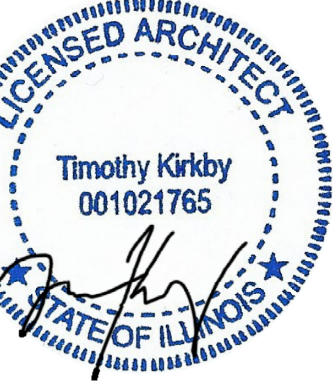

### SUMMARY OF WORK

INTERIOR REMODELING OF THE EXISTING 412 SF KITCHEN AT LEVY SENIOR CENTER. PROVIDE ALL NECESSARY ARCHITECTURAL, ELECTRICAL, HVAC AND PLUMBING WORK AS NOTED.

### OWNER

CITY OF EVANSTON  
PUBLIC WORKS AGENCY  
CONTACT: KENON BOEHM  
909 DAVIS STREET  
EVANSTON, ILLINOIS 60201  
224-296-4453 (PHONE)  
kboehm@cityofevanston.org

### LOCATION MAP

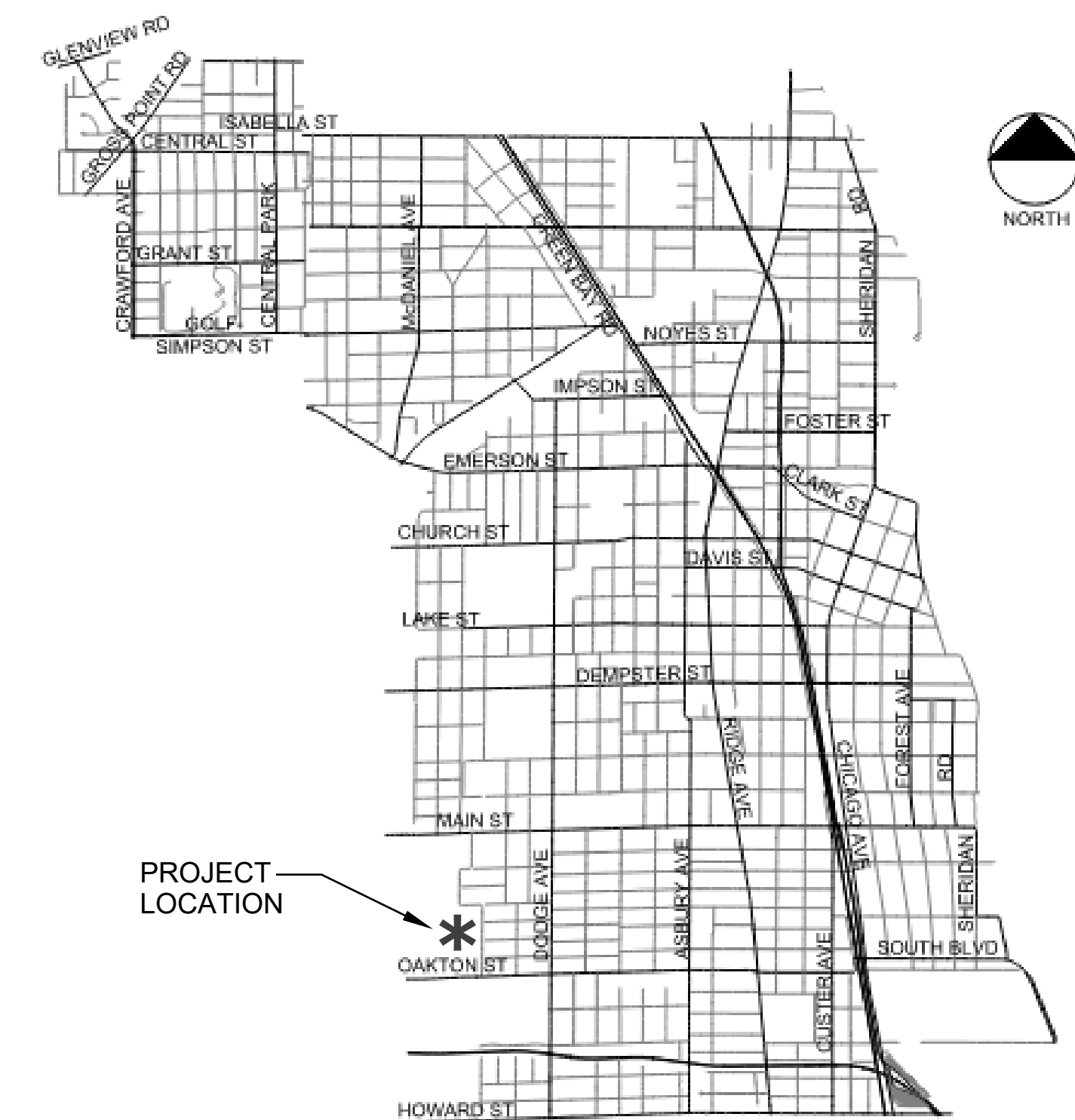

| PROJECT DATA                                                                                                                                                                                                                                                                                                                                                                                                                                                                                                                                                          |                                                                                       |                    |
|-----------------------------------------------------------------------------------------------------------------------------------------------------------------------------------------------------------------------------------------------------------------------------------------------------------------------------------------------------------------------------------------------------------------------------------------------------------------------------------------------------------------------------------------------------------------------|---------------------------------------------------------------------------------------|--------------------|
| USE GROUP CLASSIFICATION                                                                                                                                                                                                                                                                                                                                                                                                                                                                                                                                              | B                                                                                     |                    |
| CONSTRUCTION TYPE                                                                                                                                                                                                                                                                                                                                                                                                                                                                                                                                                     | III-B                                                                                 |                    |
| TOTAL FLOOR AREA                                                                                                                                                                                                                                                                                                                                                                                                                                                                                                                                                      | 412 SF                                                                                |                    |
| EXIT ACCESS TRAVEL DISTANCE                                                                                                                                                                                                                                                                                                                                                                                                                                                                                                                                           | 17 FEET                                                                               |                    |
| AUTOMATIC SPRINKLERS                                                                                                                                                                                                                                                                                                                                                                                                                                                                                                                                                  | YES                                                                                   |                    |
| OCCUPANTS                                                                                                                                                                                                                                                                                                                                                                                                                                                                                                                                                             | 3 (200 GROSS SF/ PERSON)                                                              |                    |
| MAXIMUM HEIGHT                                                                                                                                                                                                                                                                                                                                                                                                                                                                                                                                                        | 1 STORY                                                                               |                    |
| REQUIRED NUMBER OF EXITS                                                                                                                                                                                                                                                                                                                                                                                                                                                                                                                                              | 1                                                                                     |                    |
| ACTUAL NUMBER OF EXITS                                                                                                                                                                                                                                                                                                                                                                                                                                                                                                                                                | 2                                                                                     |                    |
| MINIMUM CORRIDOR WIDTH                                                                                                                                                                                                                                                                                                                                                                                                                                                                                                                                                | 48"                                                                                   |                    |
| APPLICABLE BUILDING CODES                                                                                                                                                                                                                                                                                                                                                                                                                                                                                                                                             |                                                                                       |                    |
| ALL DRAWINGS DEVELOPED TO ADHERE TO THE FOLLOWING NATIONAL & STATE CODES ADOPTED & AMENDED BY THE CITY OF EVANSTON, ILLINOIS.                                                                                                                                                                                                                                                                                                                                                                                                                                         |                                                                                       |                    |
| 2021 International Building Code (IBC) - Local IBC Amendments<br>2021 International Existing Building Code (IEBC)<br>2021 International Mechanical Code (IMC) - Local IMC Amendments<br>2021 International Fuel Gas Code (IFGC) - Local IFGC Amendments<br>2020 NFPA 70 National Electric Code (NEC) - NEC Amendments<br>2021 NFPA Life Safety Code 101<br>2021 International Fire Code (IFC) - IFC Amendments<br>Illinois Plumbing Code - Local Plumbing Code Amendments<br>2018 Illinois Accessibility Code<br>2023 Illinois Stretch Energy Code<br>2017 ICC A117.1 |                                                                                       |                    |
| DESIGN CRITERIA                                                                                                                                                                                                                                                                                                                                                                                                                                                                                                                                                       |                                                                                       |                    |
| GROUND SNOW LOAD                                                                                                                                                                                                                                                                                                                                                                                                                                                                                                                                                      | 25 LB / FT <sup>2</sup>                                                               |                    |
| ULTIMATE WIND DESIGN                                                                                                                                                                                                                                                                                                                                                                                                                                                                                                                                                  | 117 MPH                                                                               |                    |
| SEISMIC DESIGN CATEGORY                                                                                                                                                                                                                                                                                                                                                                                                                                                                                                                                               | A                                                                                     |                    |
| SUBJECT TO DAMAGE FROM:                                                                                                                                                                                                                                                                                                                                                                                                                                                                                                                                               | WEATHERING                                                                            | SEVERE             |
|                                                                                                                                                                                                                                                                                                                                                                                                                                                                                                                                                                       | FROST LINE DEPTH                                                                      | 42"                |
|                                                                                                                                                                                                                                                                                                                                                                                                                                                                                                                                                                       | TERMITE                                                                               | MODERATE TO SEVERE |
| WINTER DESIGN TEMPERATURE                                                                                                                                                                                                                                                                                                                                                                                                                                                                                                                                             | -4° F, 97 ½ %                                                                         |                    |
| SUMMER DESIGN TEMPERATURE                                                                                                                                                                                                                                                                                                                                                                                                                                                                                                                                             | 89° F Dry Bulb, 2 ½ %                                                                 |                    |
|                                                                                                                                                                                                                                                                                                                                                                                                                                                                                                                                                                       | 76° F Wet Bulb, 2 ½ %                                                                 |                    |
| ICE BARRIER UNDERLAYMENT                                                                                                                                                                                                                                                                                                                                                                                                                                                                                                                                              | REQUIRED                                                                              |                    |
| FLOOD HAZARDS                                                                                                                                                                                                                                                                                                                                                                                                                                                                                                                                                         | FIRM #170214 PANELS 0606H-0609H 12/16/2004                                            |                    |
| AIR FREEZING INDEX                                                                                                                                                                                                                                                                                                                                                                                                                                                                                                                                                    | AIR FREEZING INDEX                                                                    |                    |
| ANNUAL MEAN TEMPERATURE                                                                                                                                                                                                                                                                                                                                                                                                                                                                                                                                               | 49.4 °F                                                                               |                    |
| HEATING DEGREE DAYS (HDD)                                                                                                                                                                                                                                                                                                                                                                                                                                                                                                                                             | 6,155                                                                                 |                    |
| COOLING DEGREE DAYS (CDD)                                                                                                                                                                                                                                                                                                                                                                                                                                                                                                                                             | 942                                                                                   |                    |
| CLIMATE ZONE                                                                                                                                                                                                                                                                                                                                                                                                                                                                                                                                                          | 5A                                                                                    |                    |
| INDOOR DESIGN CONDITIONS                                                                                                                                                                                                                                                                                                                                                                                                                                                                                                                                              | MAX. 76° F - HEATING                                                                  |                    |
|                                                                                                                                                                                                                                                                                                                                                                                                                                                                                                                                                                       | MIN. 76° F - COOLING                                                                  |                    |
| INDEX OF DRAWINGS                                                                                                                                                                                                                                                                                                                                                                                                                                                                                                                                                     |                                                                                       |                    |
| G                                                                                                                                                                                                                                                                                                                                                                                                                                                                                                                                                                     | COVER PAGE & GENERAL NOTES                                                            |                    |
| A                                                                                                                                                                                                                                                                                                                                                                                                                                                                                                                                                                     | DEMOLITION & NEW WORK PLANS, ELEVATIONS                                               |                    |
| E                                                                                                                                                                                                                                                                                                                                                                                                                                                                                                                                                                     | ELECTRICAL PLAN & PANEL SCHEDULE                                                      |                    |
| M                                                                                                                                                                                                                                                                                                                                                                                                                                                                                                                                                                     | MECHANICAL PLAN & SCHEDULES, ELECTRICAL POWER PLAN, REFLECTED CEILING PLAN, ROOF PLAN |                    |
| P                                                                                                                                                                                                                                                                                                                                                                                                                                                                                                                                                                     | PLUMBING PLANS & RISER DIAGRAMS                                                       |                    |

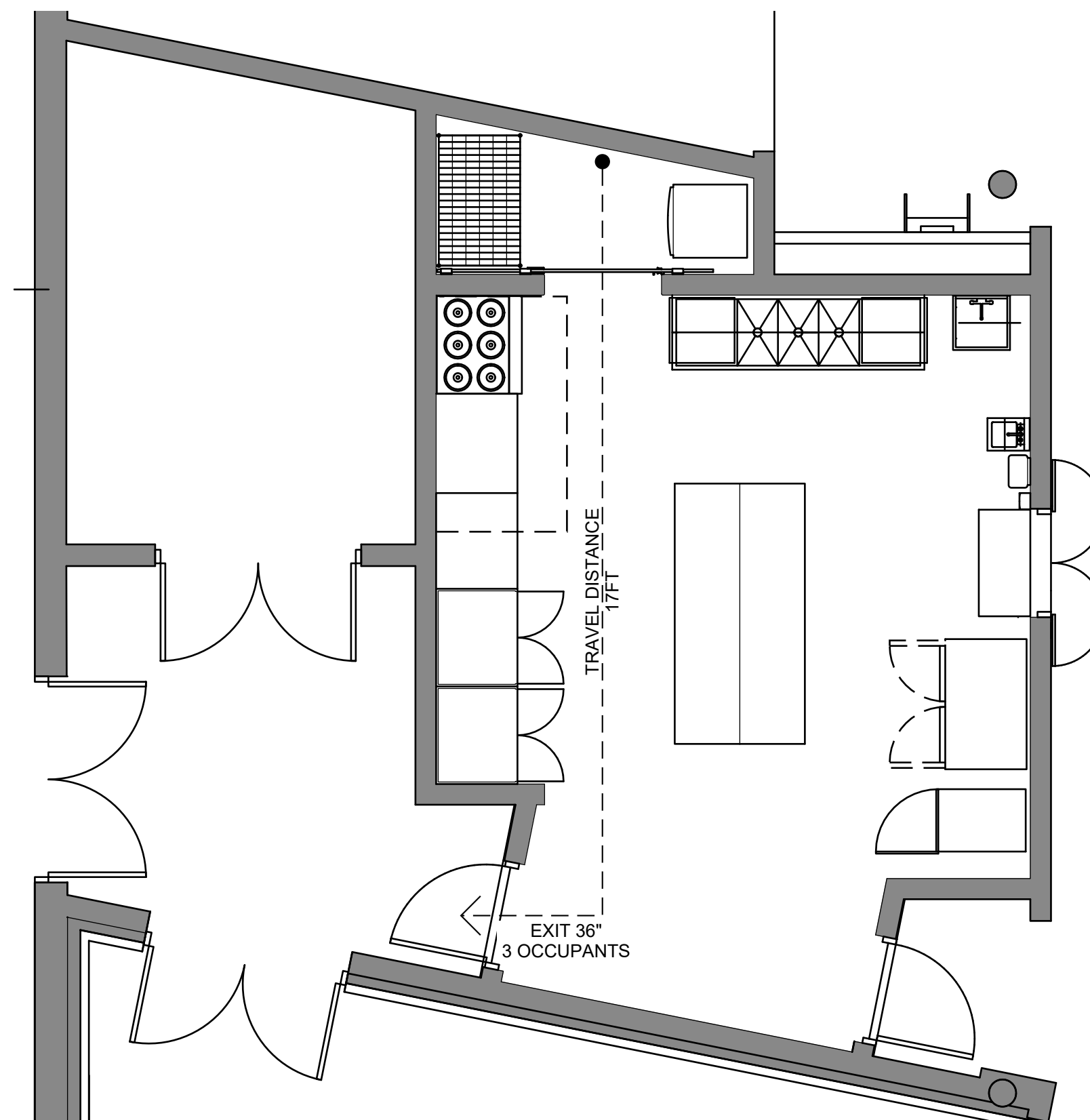

### LIFE SAFETY PLAN

SCALE :: 1/4" = 1'-0"

**Levy Senior Center - Kitchen Interior Remodel**  
300 Dodge Ave, Evanston, IL 60202

**ARCHITECT:** T. KIRKBY  
6874 N. NW HWY  
CHICAGO, IL 60631  
773.225.7166

**CONTRACTOR:** TBD

**OWNER:** City of Evanston

**DRAWN BY:** TK  
**DOCUMENT DATE:** January 8, 2026

**CHECKED BY:** MD  
**JOB#:** 2025.01

- ▲ 8.7.2025 ISSUED FOR REVIEW
- ▲ 9.29.2025 ISSUED FOR PERMIT
- ▲ 11.20.2025 REVISION 1
- ▲ 1.8.2026 ISSUED FOR REVIEW
- ▲ 4.16.2026 ISSUED FOR BID
- ▲
- ▲
- ▲
- ▲
- ▲



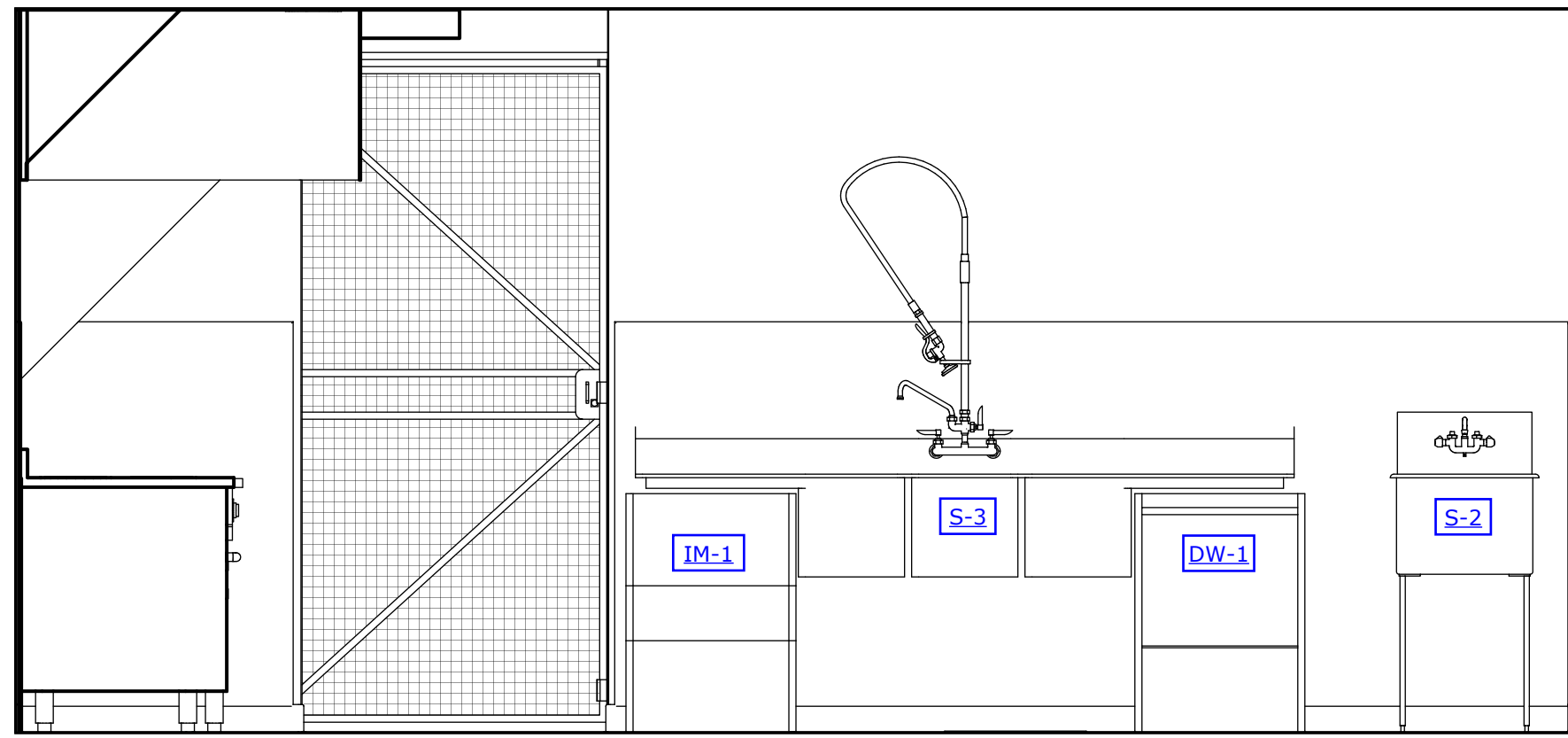

**1 EAST ELEVATION - SINKS**  
SCALE :: 1/4" = 1' - 0"

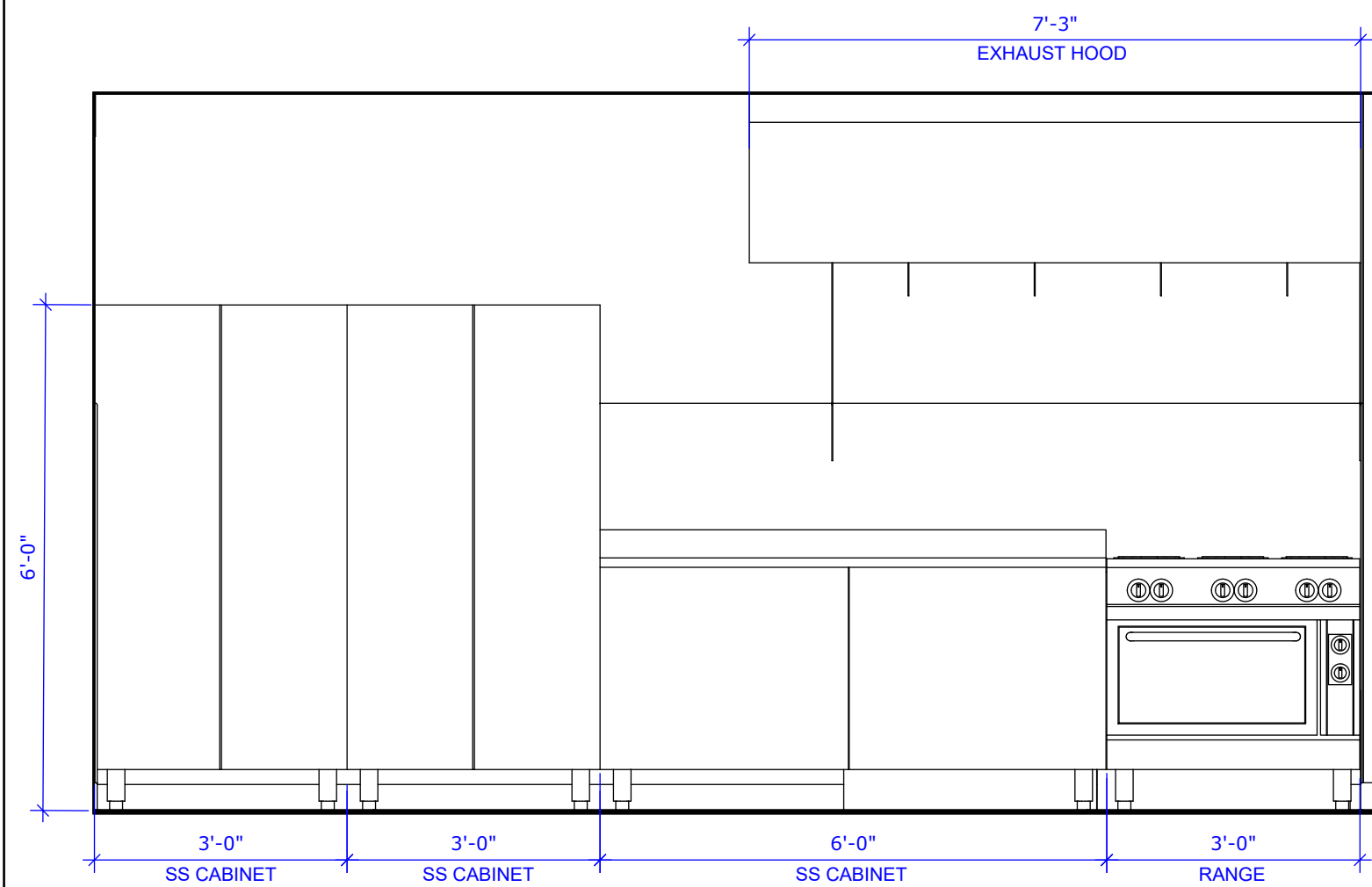

**2 NORTH ELEVATION - RANGE / OVEN**  
SCALE :: 1/4" = 1' - 0"

- NEW WORK PLAN NOTES**
- 1 STAINLESS STEEL WORKSTATION W/ LOCKABLE BASE CABINET
  - 2 COMMERCIAL EXHAUST HOOD
  - 3 ELECTRIC RANGE & OVEN
  - 4 4' X 8' SLIDING DOOR W/ 10 GAUGE WIRE MESH & LOCK
  - 5 30" X 48" WIRE SHELVING
  - 6 STACKED COMMERCIAL WASHER / DRYER
  - 7 EXISTING ICE MAKER (RETAIN)
  - 8 EXISTING TRIPLE BASIN SINK
  - 9 NEW GREASE TRAP
  - 10 NEW COMMERCIAL DISHWASHER
  - 11 NEW STAINLESS STEEL PREP SINK
  - 12 WALL-MOUNTED STAINLESS STEEL HAND SINK, MOUNTED AT 34" ABOVE FLOOR
  - 13 WALL-MOUNTED PAPER TOWEL DISPENSER
  - 14 WALL-MOUNTED SOAP DISPENSER
  - 15 STAINLESS STEEL 30" X 19" FOLDING COUNTERTOP
  - 16 EXISTING REFRIGERATOR
  - 17 MOBILE WARMING CABINET
  - 18 STAINLESS STEEL WORKSTATIONS, BACK-TO-BACK
  - 19 STAINLESS STEEL FULL-HEIGHT LOCKABLE CABINET(S) W/ SHELVES. (QUANTITY & DIMENSIONS TBD)

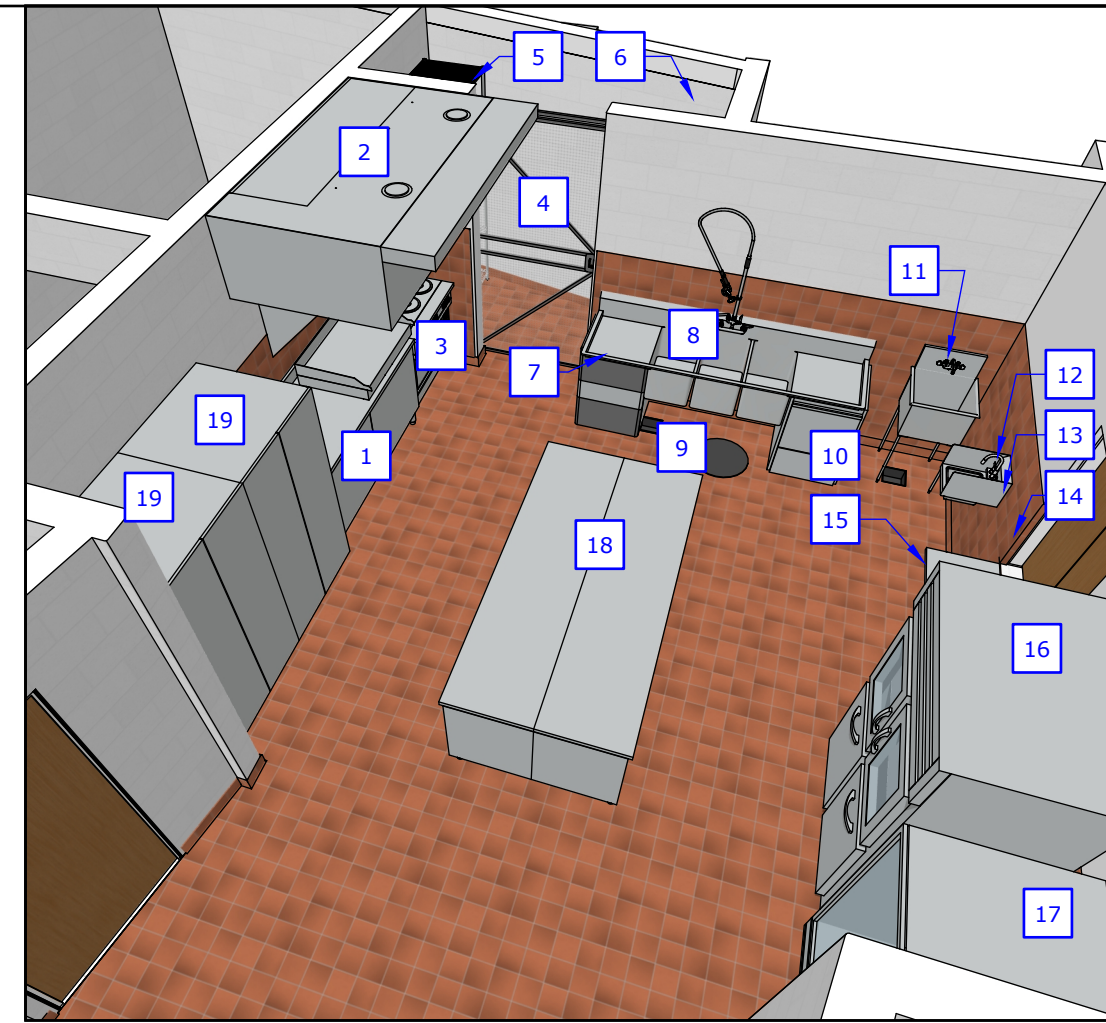

- DEMOLITION FLOOR PLAN NOTES**
- 1 REMOVE GAS RANGE; CAP & SEAL GAS LINE BELOW FLOOR
  - 2 DEMOLISH & DISPOSE OF EXHAUST HOOD OVER ISLAND & ASSOCIATED DUCTWORK. REPLACE W/ CEILING TILE TO MATCH EXISTING
  - 3 DEMOLISH & DISPOSE OF ISLAND
  - 4 DEMOLISH & DISPOSE OF ALL CABINETS & COUNTERTOPS
  - 5 REMOVE WALL-HUNG SINK
  - 6 TRIPLE BASIN SINK - REMAIN IN PLACE

- ITEMS TO PRESERVE**
- 7 REFRIGERATOR & FREEZER
  - 8 CEILING GRIDS AND CEILING LIGHTS
  - 9 ELECTRICAL OUTLETS, UNLESS NOTED OTHERWISE
  - 10 CERAMIC FLOOR & WALL TILE

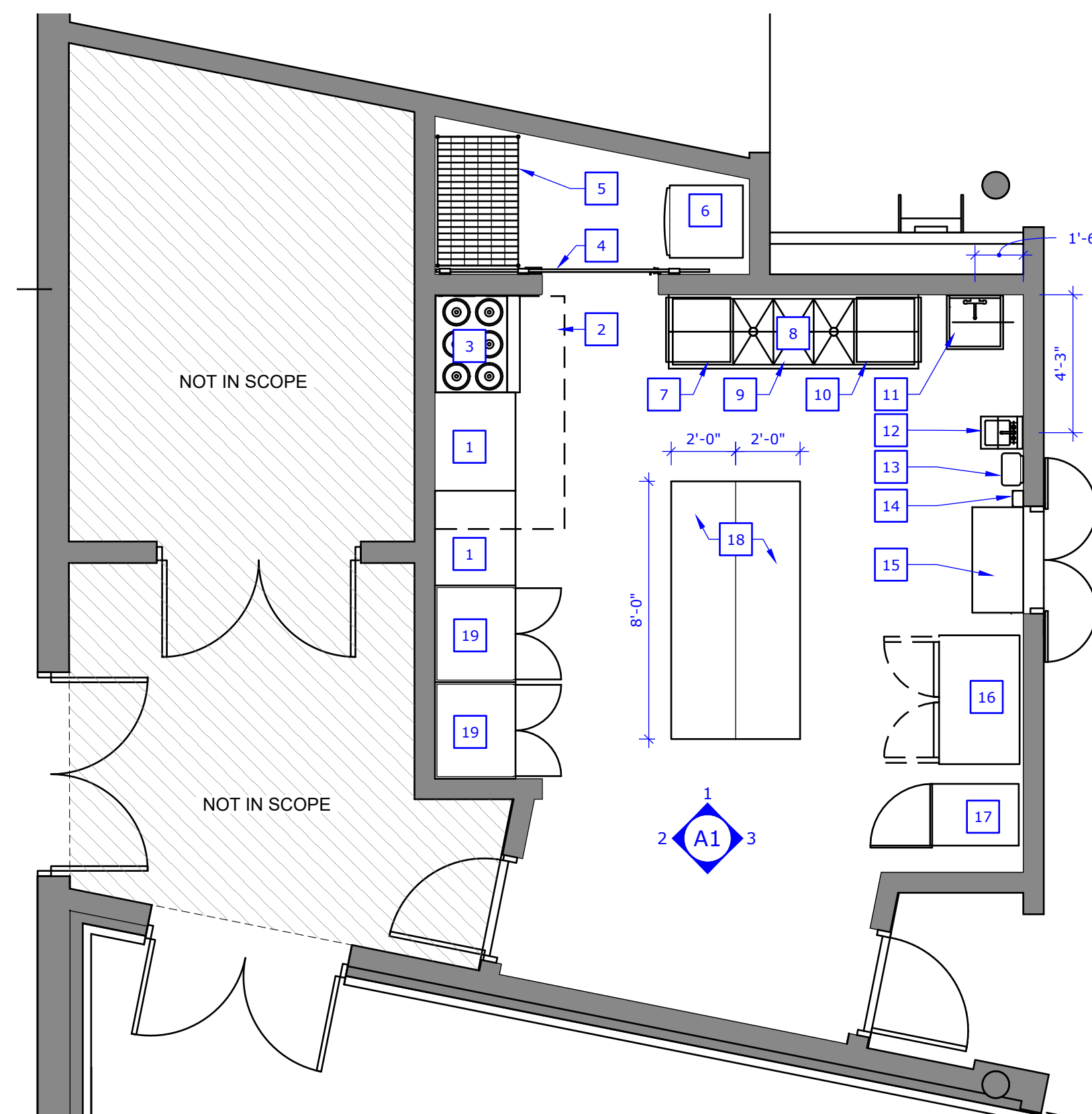
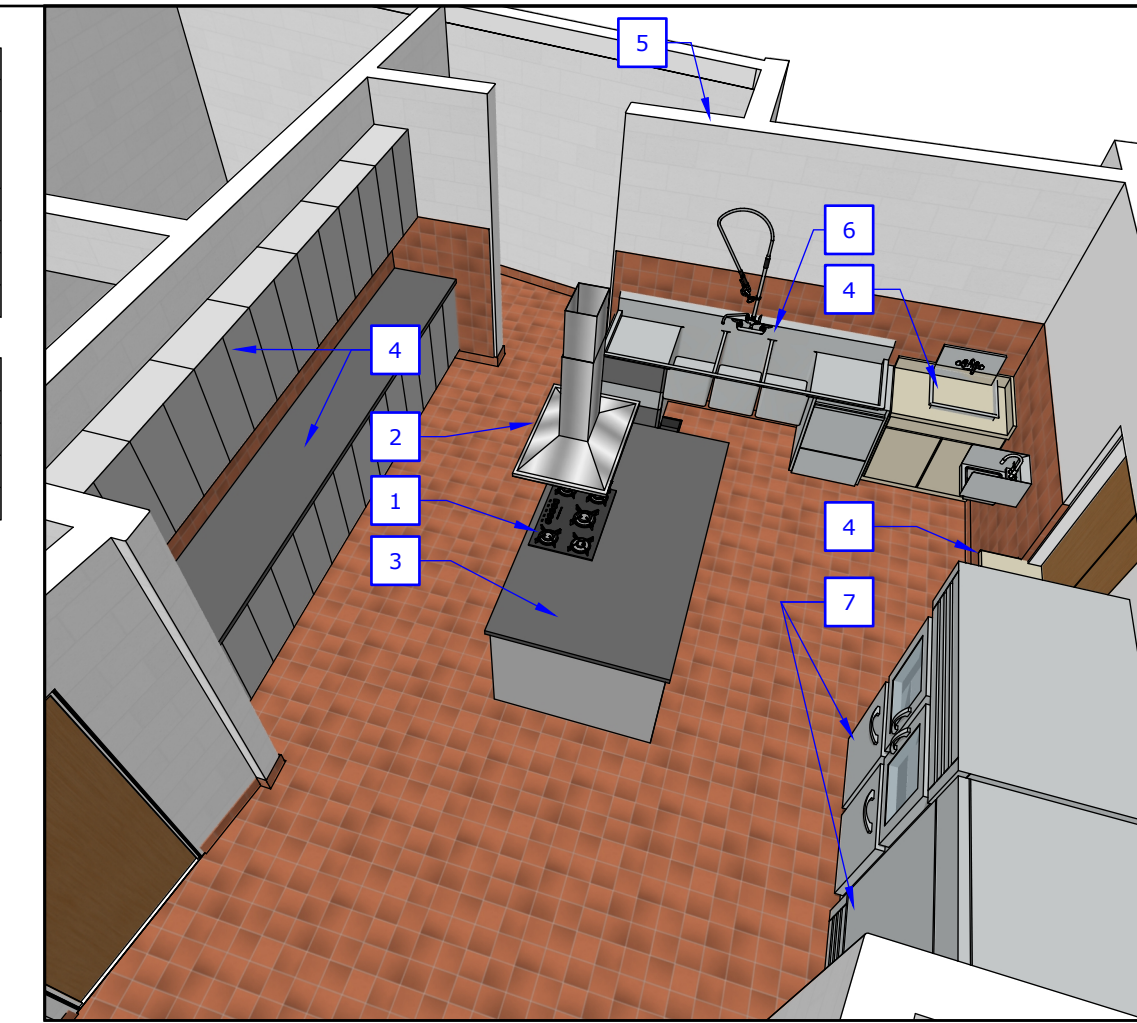

**2 FLOOR PLAN - NEW WORK**  
SCALE :: 1/4" = 1' - 0"

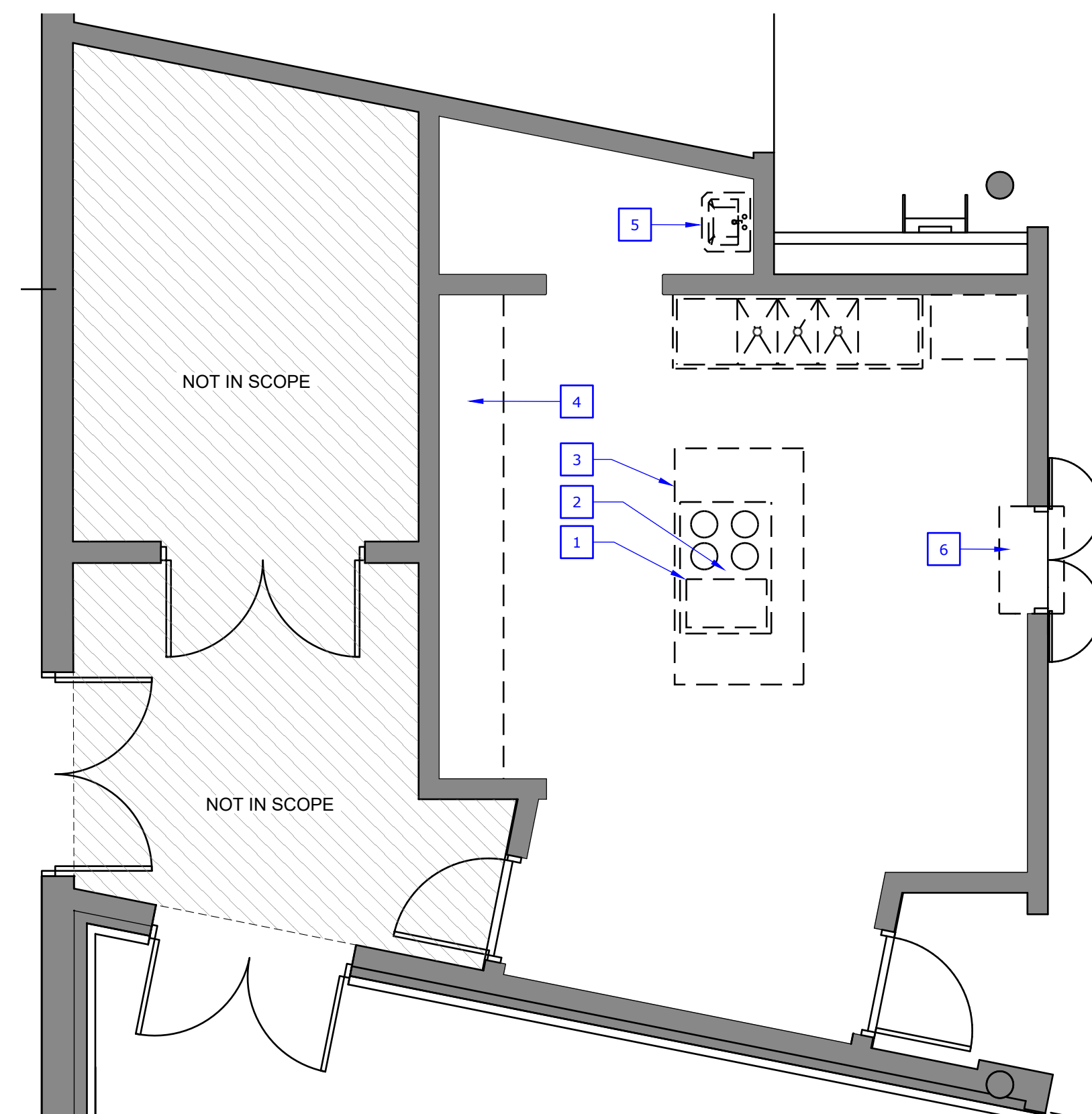

**1 FLOOR PLAN - DEMOLITION**  
SCALE :: 1/4" = 1' - 0"

**Levy Senior Center - Kitchen Interior Remodel**  
300 Dodge Ave, Evanston, IL 60202

**ARCHITECT:** T. KIRKBY  
6874 N. NW HWY  
CHICAGO, IL 60631  
773.225.7166

**CONTRACTOR:** TBD

**OWNER:** City of Evanston

**DRAWN BY:** TK  
**DOCUMENT DATE:** January 8, 2026

**CHECKED BY:** MD  
**JOB#:** 2025.01

- ▲ 8.7.2025 ISSUED FOR REVIEW
- ▲ 9.29.2025 ISSUED FOR PERMIT
- ▲ 11.20.2025 REVISION 1
- ▲ 1.8.2026 ISSUED FOR REVIEW
- ▲ 4.16.2026 ISSUED FOR BID
- ▲
- ▲
- ▲
- ▲
- ▲



| EXISTING PANEL RP-3                |                             |                        |             |                   |                       |                           |        |        |        |              |          |                             |        |
|------------------------------------|-----------------------------|------------------------|-------------|-------------------|-----------------------|---------------------------|--------|--------|--------|--------------|----------|-----------------------------|--------|
| PANEL DESIGNATION: RP-3 (EXISTING) |                             | MAIN TYPE: 125A MB     |             | MOUNTING: SURFACE |                       | BRANCH OCP TYPE: BL (STD) |        |        |        |              |          |                             |        |
| VOLTAGE: 120/208Y                  |                             | MAIN OPTIONS: EXISTING |             | EXCLOSURE: NEMA 1 |                       | FAULT DUTY: 10KA          |        |        |        |              |          |                             |        |
| PANEL OPTIONS: 3PH / 4W            |                             | BUS AMPS: 125A         |             | NEUTRAL BUS: STD  |                       | INTEGRAL SPD: -           |        |        |        |              |          |                             |        |
| GROUND BUS: MCB                    |                             | GROUND BUS: STD        |             | OWNER METERS: -   |                       | ACCESSORIES: -            |        |        |        |              |          |                             |        |
| CKT. #                             | DESCRIPTION                 | OCP SIZE               | OCP OPTIONS | A                 | B                     | C                         | A      | B      | C      | OCP OPTIONS  | OCP SIZE | DESCRIPTION                 | CKT. # |
| 1                                  | (EXISTING) FPBs 11,12,13,14 | 20A                    | -           | 1000              |                       |                           | 1000   |        |        | -            | 20A      | (EXISTING) FPBs 24,25,26,27 | 2      |
| 3                                  | (EXISTING) FPBs 15,16,17    | 20A                    | -           |                   | 1000                  |                           |        | 1000   |        | -            | 20A      | (EXISTING) FPBs 8,9,10      | 6      |
| 7                                  | (EXISTING) FPBs 18,19,20,21 | 20A                    | -           | 750               |                       |                           | 750    |        |        | -            | 20A      | (EXISTING) HD-3 (Rm 137)    | 10     |
| 9                                  | (EXISTING) FPBs 1,2,3       | 20A                    | -           |                   | 1000                  |                           |        | 2400   |        | -            | 25A      | (EXISTING) HD-4 (Rm 136)    | 12     |
| 13                                 | (EXISTING) FPBs 4,5,6,7     | 20A                    | -           | 750               |                       |                           | 2400   |        |        | -            | 25A      | (EXISTING) HD-5 (Rm 152)    | 14     |
| 15                                 | (EXISTING) UH-1             | 20A                    | -           |                   | 750                   |                           |        | 2400   |        | -            | 25A      | (EXISTING) HD-6 (Rm 153)    | 16     |
| 17                                 | SPARE (EF-4 Rm 145)         | 20A                    | -           |                   | 1000                  |                           |        | 1500   |        | -            | 20A      | (EXISTING) UH-4             | 20     |
| 19                                 | (EXISTING) SPARE            | 20A                    | -           | 1000              |                       |                           | 1500   |        |        | -            | 20A      | (EXISTING) SPARE            | 22     |
| 21                                 | SPARE (EF-4 Rm 145)         | 20A                    | -           |                   | 1500                  |                           |        | 0      |        | -            | 20A      | (EXISTING) SPARE            | 24     |
| 23                                 | (EXISTING) SPARE            | 20A                    | -           | 0                 |                       |                           | 6125   |        |        | -            | 70A      | NEW KITCHEN RANGE           | 26     |
| 25                                 | (EXISTING) SPARE            | 20A                    | -           | 0                 |                       |                           | 6125   |        |        | -            | 70A      | SPARE (Kitchen Oven)        | 30     |
| 27                                 | (EXISTING) SPARE            | 20A                    | -           | 0                 |                       |                           | 6125   |        |        | -            | 70A      | SPARE (Rm 145)              | 32     |
| 29                                 | (EXISTING) FPBs 22,23,28,29 | 20A                    | -           | 1000              |                       |                           | 0      |        |        | -            | 20A      | (EXISTING) SPARE            | 34     |
| 31                                 | SPARE (EF Hood Rm 145)      | 20A                    | -           |                   | 0                     |                           | 0      |        |        | -            | 20A      | (EXISTING) SPARE            | 36     |
| 33                                 | SPARE (Island GFI Rm 145)   | 20A                    | -           |                   | 0                     |                           | 0      |        |        | -            | 20A      | (EXISTING) SPARE            | 38     |
| 35                                 | SPARE (Cooktop Rm 145)      | 20A                    | -           |                   | 0                     |                           | 0      |        |        | -            | 20A      | (EXISTING) SPARE            | 40     |
| 37                                 | (EXISTING) SPARE            | 20A                    | -           | 0                 |                       |                           | 0      |        |        | -            | 20A      | (EXISTING) SPARE            | 42     |
| 39                                 | (EXISTING) SPARE            | 20A                    | -           | 0                 |                       |                           | 0      |        |        | -            | 20A      | (EXISTING) SPARE            | 44     |
| 41                                 | (EXISTING) SPARE            | 20A                    | -           | 0                 |                       |                           | 0      |        |        | -            | 20A      | (EXISTING) SPARE            | 46     |
| <b>TOTAL</b>                       |                             |                        |             | 4,500             | 4,250                 | 3,750                     | 11,775 | 11,925 | 10,775 | <b>TOTAL</b> |          |                             |        |
| TOTAL PHASE A:                     |                             |                        |             | 16,275            | TOTAL CONNECTED LOAD: |                           |        |        | 47.0   | kVA          |          |                             |        |
| TOTAL PHASE B:                     |                             |                        |             | 16,175            | TOTAL DEMAND LOAD:    |                           |        |        | 130.39 | AMP          |          |                             |        |
| TOTAL PHASE C:                     |                             |                        |             | 14,525            |                       |                           |        |        | 75.28  | AMP          |          |                             |        |

| EXISTING PANEL LP-3                |                            |                        |             |                   |                       |                           |       |       |       |              |          |                       |        |
|------------------------------------|----------------------------|------------------------|-------------|-------------------|-----------------------|---------------------------|-------|-------|-------|--------------|----------|-----------------------|--------|
| PANEL DESIGNATION: LP-3 (EXISTING) |                            | MAIN TYPE: 200A        |             | MOUNTING: SURFACE |                       | BRANCH OCP TYPE: BL (STD) |       |       |       |              |          |                       |        |
| VOLTAGE: 277/480Y                  |                            | MAIN OPTIONS: EXISTING |             | EXCLOSURE: NEMA 1 |                       | FAULT DUTY: 10KA          |       |       |       |              |          |                       |        |
| PANEL OPTIONS: 3PH / 4W            |                            | BUS AMPS: 200A         |             | NEUTRAL BUS: STD  |                       | INTEGRAL SPD: -           |       |       |       |              |          |                       |        |
| GROUND BUS: MCB                    |                            | GROUND BUS: STD        |             | OWNER METERS: -   |                       | ACCESSORIES: -            |       |       |       |              |          |                       |        |
| CKT. #                             | DESCRIPTION                | OCP SIZE               | OCP OPTIONS | A                 | B                     | C                         | A     | B     | C     | OCP OPTIONS  | OCP SIZE | DESCRIPTION           | CKT. # |
| 1                                  | (EXISTING) LITE RMS M01-03 | 20A                    | -           | 1800              |                       |                           | 6250  |       |       | -            | 45A      | NEW MAKE-UP AIR MUA-1 | 2      |
| 3                                  | (EXISTING) STAGE LIGHTING  | 20A                    | -           |                   | 1800                  |                           |       | 6250  |       | -            | 45A      | (EXISTING) SPARE      | 4      |
| 5                                  | (EXISTING) STAGE LIGHTING  | 20A                    | -           |                   |                       | 1800                      |       |       | 6250  | -            | 20A      | (EXISTING) SPARE      | 6      |
| 7                                  | (EXISTING) STAGE LIGHTING  | 20A                    | -           | 1800              |                       |                           | 0     |       |       | -            | 20A      | (EXISTING) SPARE      | 8      |
| 9                                  | (EXISTING) SPARE           | 20A                    | -           | 0                 |                       |                           | 0     |       |       | -            | 20A      | (EXISTING) SPARE      | 10     |
| 11                                 | (EXISTING) SPARE           | 20A                    | -           | 0                 |                       |                           | 0     |       |       | -            | 20A      | (EXISTING) SPARE      | 12     |
| 13                                 | (EXISTING) SPARE           | 20A                    | -           | 0                 |                       |                           | 0     |       |       | -            | 20A      | (EXISTING) SPARE      | 14     |
| 15                                 | (EXISTING) SPARE           | 20A                    | -           | 0                 |                       |                           | 0     |       |       | -            | 20A      | (EXISTING) SPARE      | 16     |
| 17                                 | (EXISTING) SPARE           | 20A                    | -           | 0                 |                       |                           | 0     |       |       | -            | 20A      | (EXISTING) SPARE      | 18     |
| 19                                 | (EXISTING) SPARE           | 20A                    | -           | 0                 |                       |                           | 0     |       |       | -            | 20A      | (EXISTING) SPARE      | 20     |
| 21                                 | (EXISTING) SPARE           | 20A                    | -           | 0                 |                       |                           | 0     |       |       | -            | 20A      | (EXISTING) SPARE      | 22     |
| 23                                 | (EXISTING) SPARE           | 20A                    | -           | 0                 |                       |                           | 0     |       |       | -            | 20A      | (EXISTING) SPARE      | 24     |
| 25                                 | (EXISTING) GYM LIGHTING    | 20A                    | -           | 1800              |                       |                           | 0     |       |       | -            | 20A      | (EXISTING) SPARE      | 26     |
| 27                                 | (EXISTING) GYM LIGHTING    | 20A                    | -           |                   | 1800                  |                           | 0     |       |       | -            | 20A      | (EXISTING) SPARE      | 28     |
| 29                                 | (EXISTING) GYM LIGHTING    | 20A                    | -           |                   |                       | 1800                      | 0     |       |       | -            | 20A      | (EXISTING) SPARE      | 30     |
| 31                                 | (EXISTING) GYM LIGHTING    | 20A                    | -           | 1800              |                       |                           | 0     |       |       | -            | 20A      | (EXISTING) SPARE      | 32     |
| 33                                 | (EXISTING) SPARE           | 20A                    | -           | 0                 |                       |                           | 0     |       |       | -            | 20A      | (EXISTING) SPARE      | 34     |
| 35                                 | (EXISTING) SPARE           | 20A                    | -           | 0                 |                       |                           | 0     |       |       | -            | 20A      | (EXISTING) SPARE      | 36     |
| 37                                 | (EXISTING) SPARE           | 20A                    | -           | 0                 |                       |                           | 0     |       |       | -            | 20A      | (EXISTING) SPARE      | 38     |
| 39                                 | (EXISTING) SPARE           | 20A                    | -           | 0                 |                       |                           | 0     |       |       | -            | 20A      | (EXISTING) SPARE      | 40     |
| 41                                 | (EXISTING) SPARE           | 20A                    | -           | 0                 |                       |                           | 0     |       |       | -            | 20A      | (EXISTING) SPARE      | 42     |
| <b>TOTAL</b>                       |                            |                        |             | 7,200             | 3,600                 | 3,600                     | 6,250 | 6,250 | 6,250 | <b>TOTAL</b> |          |                       |        |
| TOTAL PHASE A:                     |                            |                        |             | 13,450            | TOTAL CONNECTED LOAD: |                           |       |       | 33.2  | kVA          |          |                       |        |
| TOTAL PHASE B:                     |                            |                        |             | 9,850             | TOTAL DEMAND LOAD:    |                           |       |       | 92.02 | AMP          |          |                       |        |
| TOTAL PHASE C:                     |                            |                        |             | 9,850             |                       |                           |       |       | 53.13 | AMP          |          |                       |        |

| ELECTRICAL LEGEND     |                                                    |
|-----------------------|----------------------------------------------------|
| ⊙ <sub>S</sub>        | SMOKE DETECTOR                                     |
| ⊕ <sub>G</sub>        | GROUND-FAULT CIRCUIT INTERRUPTER RECEPTACLE OUTLET |
| ⊕                     | DUPLEX RECEPTACLE OUTLET                           |
| ⊕ <sub>208V/3ØV</sub> | 208V / 3PHASE RECEPTACLE OUTLET                    |
| ⊕ <sub>4</sub>        | QUAD PLEX OUTLET                                   |
| ⊕ <sub>C</sub>        | DUPLEX OUTLET AT CEILING LEVEL                     |
| ⊞                     | SWITCH                                             |
| ⊞ <sub>3</sub>        | 3 WAY SWITCH                                       |
| ▭                     | ELECTRICAL PANEL                                   |

| ELECTRICAL NOTES |                                                          |
|------------------|----------------------------------------------------------|
| 1                | NO CHANGES TO OUTLETS OR SWITCHES UNLESS NOTED OTHERWISE |
| 2                | EXISTING TRANSFORMER                                     |
| 3                | EXISTING ELECTRICAL PANEL                                |
| 4                |                                                          |
| 5                |                                                          |
| 6                |                                                          |

| EXISTING KITCHEN PANEL                                                                                                      |                           |                        |             |                   |                       |                           |       |       |       |              |          |                           |        |  |  |
|-----------------------------------------------------------------------------------------------------------------------------|---------------------------|------------------------|-------------|-------------------|-----------------------|---------------------------|-------|-------|-------|--------------|----------|---------------------------|--------|--|--|
| PANEL DESIGNATION: KITCHEN-EXISTING                                                                                         |                           | MAIN TYPE: 100A MB     |             | MOUNTING: SURFACE |                       | BRANCH OCP TYPE: BL (STD) |       |       |       |              |          |                           |        |  |  |
| VOLTAGE: 120/208Y                                                                                                           |                           | MAIN OPTIONS: EXISTING |             | EXCLOSURE: NEMA 1 |                       | FAULT DUTY: 10KA          |       |       |       |              |          |                           |        |  |  |
| PANEL OPTIONS: 3PH / 4W                                                                                                     |                           | BUS AMPS: 100A         |             | NEUTRAL BUS: STD  |                       | INTEGRAL SPD: -           |       |       |       |              |          |                           |        |  |  |
| GROUND BUS: MCB                                                                                                             |                           | GROUND BUS: STD        |             | OWNER METERS: -   |                       | ACCESSORIES: -            |       |       |       |              |          |                           |        |  |  |
| CKT. #                                                                                                                      | DESCRIPTION               | OCP SIZE               | OCP OPTIONS | A                 | B                     | C                         | A     | B     | C     | OCP OPTIONS  | OCP SIZE | DESCRIPTION               | CKT. # |  |  |
| 1                                                                                                                           | (EXST) REFRIGERATOR       | 20A                    | -           | 1200              |                       |                           | 1260  |       |       | -            | 20A      | (EXST) FREEZER            | 2      |  |  |
| 3                                                                                                                           | (EXST) KITCHEN SOUTH WALL | 20A                    | -           |                   | 360                   |                           |       | 360   |       | -            | 20A      | (EXST) KITCHEN SOUTH WALL | 4      |  |  |
| 5                                                                                                                           | (EXST) SPARE              | 20A                    | -           |                   | 0                     |                           |       | 1120  |       | -            | 20A      | (EXST) ICE MAKER          | 6      |  |  |
| 7                                                                                                                           | (EXST) MICROWAVE          | 20A                    | -           | 1400              |                       |                           | 1590  |       |       | -            | 20A      | HOOD EXHAUST FAN (KEF-1)  | 8      |  |  |
| 9                                                                                                                           | (EXST) KITCHEN NORTH WALL | 20A                    | -           |                   | 360                   |                           |       | 3000  |       | -            | 40A      | RACK DISHWASHER           | 10     |  |  |
| 11                                                                                                                          | (EXST) KITCHEN NORTH WALL | 20A                    | -           |                   | 360                   |                           |       | 3000  |       | -            | 40A      | SPARE                     | 12     |  |  |
| 13                                                                                                                          | (EXST) KITCHEN NORTH WALL | 20A                    | -           | 360               |                       |                           | 4680  |       |       | -            | 50A      | 10.8 KW 208V GRIDDLE      | 14     |  |  |
| 15                                                                                                                          | CLOTHES WASHER            | 15A                    | -           |                   | 1200                  |                           |       | 4680  |       | -            | 50A      | CLG RECEPT (WARMING CAB)  | 16     |  |  |
| 17                                                                                                                          | CLOTHES DRYER             | 30A                    | -           |                   | 2500                  |                           |       | 1575  |       | -            | 20A      | SPARE                     | 18     |  |  |
| 19                                                                                                                          | SPARE                     | 20A                    | -           | 2500              |                       |                           | 0     |       |       | -            | 20A      | SPARE                     | 20     |  |  |
| 21                                                                                                                          | SPARE                     | 20A                    | -           | 0                 |                       |                           | 0     |       |       | -            | 20A      | SPARE                     | 22     |  |  |
| 23                                                                                                                          | SPARE                     | 20A                    | -           | 0                 |                       |                           | 0     |       |       | -            | 20A      | SPARE                     | 24     |  |  |
| 25                                                                                                                          | SPARE                     | 20A                    | -           | 0                 |                       |                           | 0     |       |       | -            | 20A      | SPARE                     | 26     |  |  |
| 27                                                                                                                          | SPARE                     | 20A                    | -           | 0                 |                       |                           | 0     |       |       | -            | 20A      | SPARE                     | 28     |  |  |
| 29                                                                                                                          | SPARE                     | 20A                    | -           | 0                 |                       |                           | 0     |       |       | -            | 20A      | SPARE                     | 30     |  |  |
| <b>TOTAL</b>                                                                                                                |                           |                        |             | 5,460             | 1,920                 | 2,860                     | 7,530 | 8,040 | 5,695 | <b>TOTAL</b> |          |                           |        |  |  |
| TOTAL PHASE A:                                                                                                              |                           |                        |             | 12,990            | TOTAL CONNECTED LOAD: |                           |       |       | 31.5  | kVA          |          |                           |        |  |  |
| TOTAL PHASE B:                                                                                                              |                           |                        |             | 9,960             | TOTAL DEMAND LOAD:    |                           |       |       | 87.45 | AMP          |          |                           |        |  |  |
| TOTAL PHASE C:                                                                                                              |                           |                        |             | 8,555             |                       |                           |       |       | 71.11 | AMP          |          |                           |        |  |  |
| NOTE: GC AND EC TO VERIFY ALL EQUIPMENT FINAL EQUIPMENT SPECIFICATIONS WITH TENANT PRIOR TO INSTALLING CIRCUITS AND WIRING. |                           |                        |             |                   |                       |                           |       |       |       |              |          | 80 AMP MAXIMUM            |        |  |  |

**3** PANEL SCHEDULES  
SCALE :: 1/4" = 1' - 0"



**2** CEILING OUTLET EXAMPLE  
SCALE :: NTS

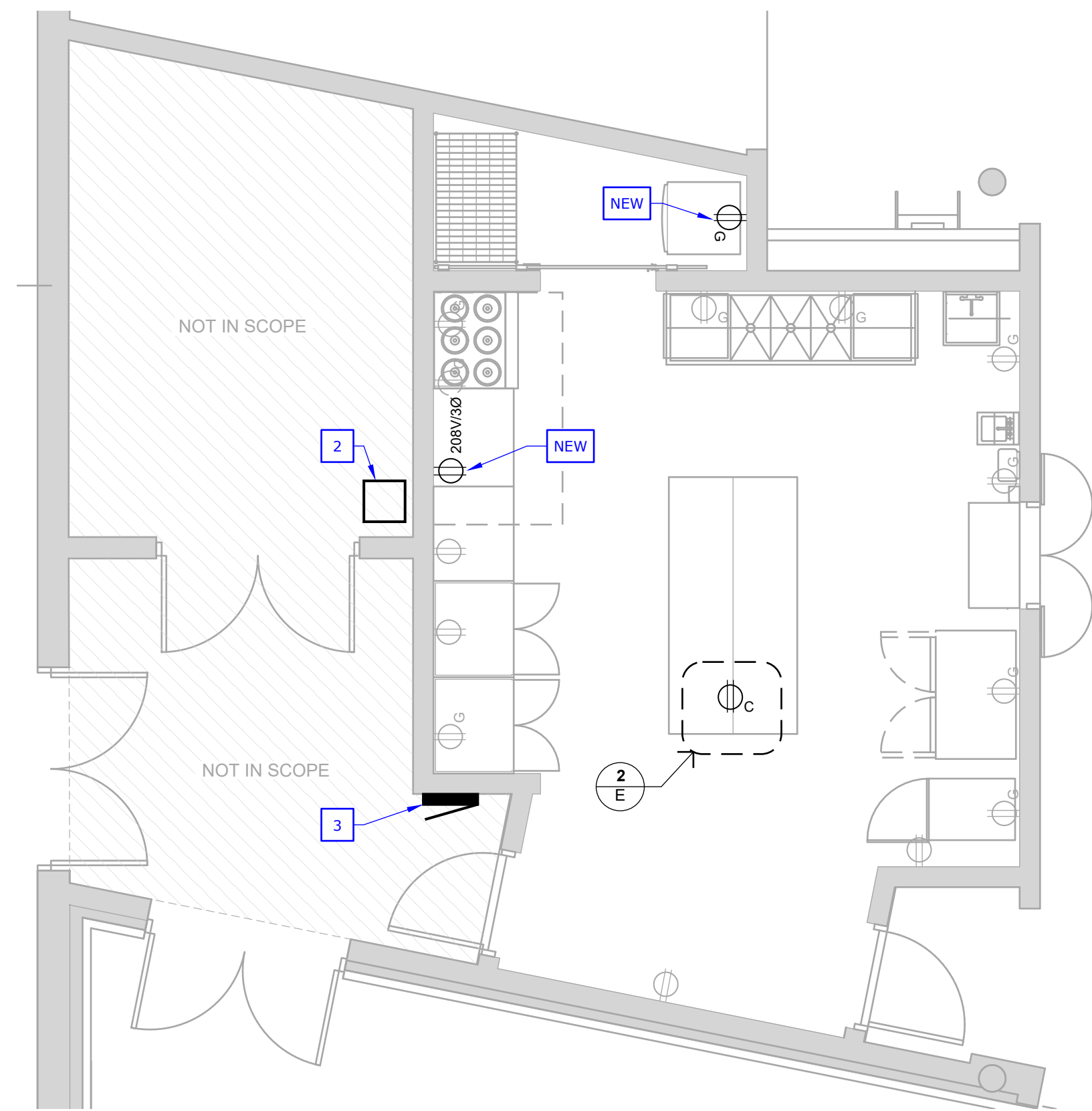

**1** ELECTRICAL PLAN  
SCALE :: 1/4" = 1' - 0"

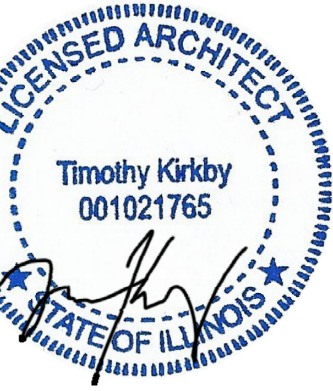

**Levy Senior Center - Kitchen Interior Remodel**

**ARCHITECT:** T. KIRKBY  
6874 N. NW HWY  
CHICAGO, IL 60631  
773.225.7166

**CONTRACTOR:** TBD  
City of Evanston

**OWNER:** City of Evanston

**DRAWN BY:** TK  
January 8, 2026

**CHECKED BY:** MD  
2025.01

- ▲ 8.7.2025 ISSUED FOR REVIEW
- ▲ 9.29.2025 ISSUED FOR PERMIT
- ▲ 11.20.2025 REVISION 1
- ▲ 1.8.2026 ISSUED FOR REVIEW
- ▲ 4.16.2026 ISSUED FOR BID
- ▲
- ▲
- ▲
- ▲
- ▲



**Levy Senior Center - Kitchen Interior Remodel**  
**ARCHITECT:** T. KIRKBY  
 6874 N. NW HWY  
 CHICAGO, IL 60631  
 773.225.7166  
**CONTRACTOR:** TBD  
**OWNER:** City of Evanston  
 300 Dodge Ave, Evanston, IL 60202  
**DOCUMENT DATE:** January 8, 2026  
**DRAWN BY:** TK  
**CHECKED BY:** MD  
**JOB#:** 2025.01

- ▲ 8.7.2025 ISSUED FOR REVIEW
- ▲ 9.29.2025 ISSUED FOR PERMIT
- ▲ 11.20.2025 REVISION 1
- ▲ 1.8.2026 ISSUED FOR REVIEW
- ▲ 4.16.2026 ISSUED FOR BID
- ▲
- ▲
- ▲
- ▲
- ▲

| MECHANICAL EQUIPMENT SCHEDULE |      |              |                  |      |                               |
|-------------------------------|------|--------------|------------------|------|-------------------------------|
| MARK                          | QTY. | MANUFACTURER | MODEL            | CFM  | REMARKS                       |
| H-1                           | 1    | Accurex      | XBEW-75.00-S     | 1350 | Exhaust Only Wall Canopy Hood |
| FS-1                          | 1    | Accurex      | FSSK-10          |      | Fire Suppression System       |
| KEF-1                         | 1    | Accurex      | XCUE-130-VG      | 1350 | Exhaust Fan                   |
| MUA-1                         | 1    | Accurex      | XMSX-P109-H12-MF | 1080 | Tempered Supply Fan           |

| OUTSIDE AIR CALCULATION PER 2021 IMC TABLE 403.3 |                                             |                                 |                          |                          |                       |                         |  |
|--------------------------------------------------|---------------------------------------------|---------------------------------|--------------------------|--------------------------|-----------------------|-------------------------|--|
| AREA                                             | OCCUPANT LOAD                               |                                 | OUTDOOR AIR (cfm/person) |                          | OUTDOOR AIR (cfm/ft2) |                         |  |
|                                                  | SQ. FT.                                     | MAX OCCUPANT LOAD (#/1,000 FT2) | TOTAL OCCUPANT LOAD      | OUTDOOR AIR (CFM/PERSON) | OUTDOOR AIR (CFM/FT2) | TOTAL OUTDOOR AIR (cfm) |  |
| KITCHEN                                          | 412                                         | 20                              | 9                        | 7.5                      | 68                    | 118                     |  |
| TOTAL OUTDOOR AIR REQUIRED                       | 0.8 (AIR DISTRIBUTION EFFECTIVENESS FACTOR) |                                 |                          |                          |                       | 118/0.8 = 147.5         |  |
| TOTAL OUTDOOR AIR PROVIDED                       | OUTSIDE FRESH AIR PROVIDED = 280 CFM        |                                 |                          |                          |                       |                         |  |

| AIR BALANCE SCHEDULE |        |        |             |             |
|----------------------|--------|--------|-------------|-------------|
| MARK                 | SUPPLY | RETURN | OUTSIDE AIR | EXHAUST AIR |
| AHU-1                | 800    | 800    | 280         |             |
| KEF-1                |        |        |             | 1350        |
| MUA-1                |        |        | 1080        |             |

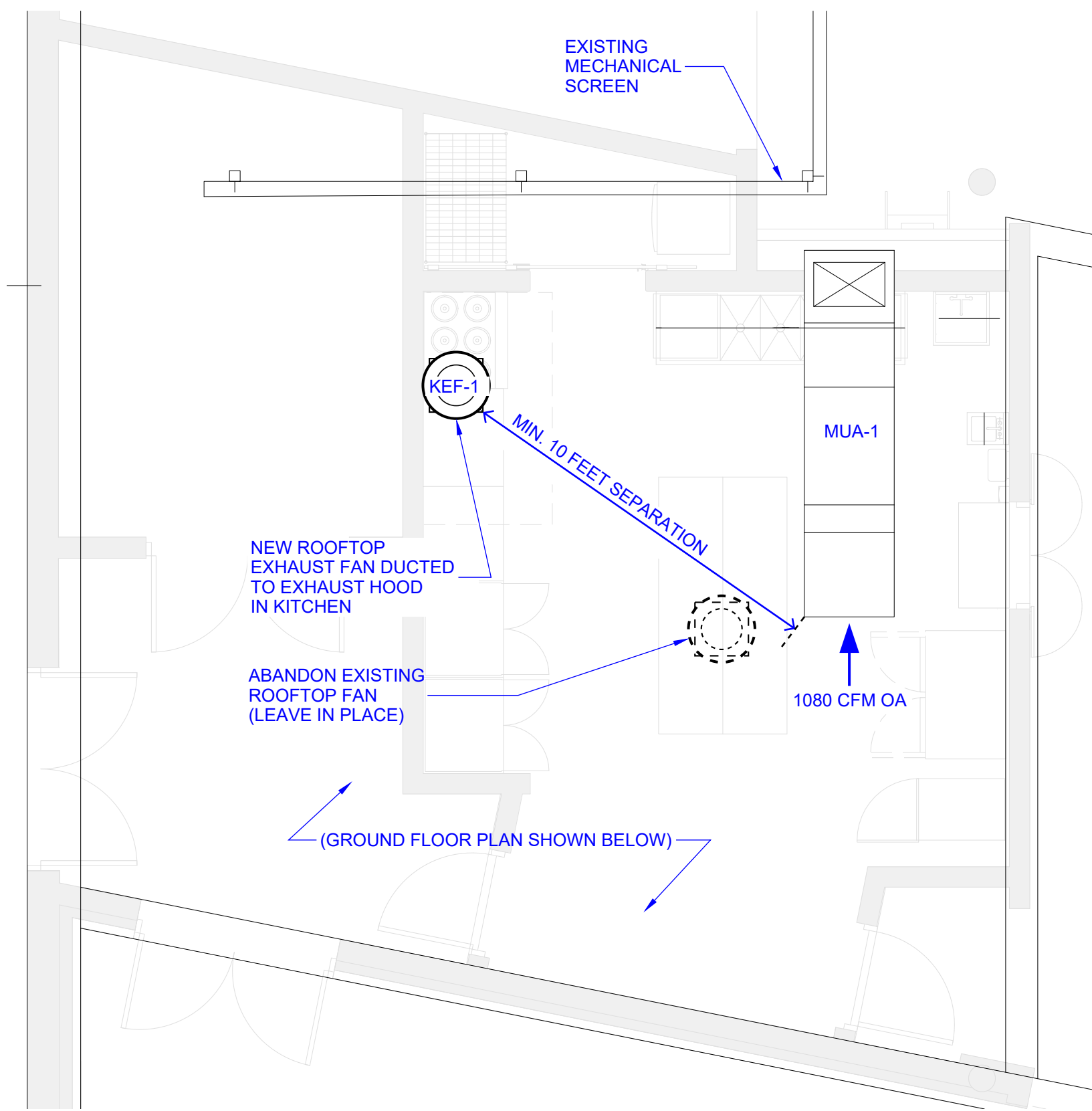

**3** ROOF PLAN  
 SCALE :: 1/4" = 1' - 0"

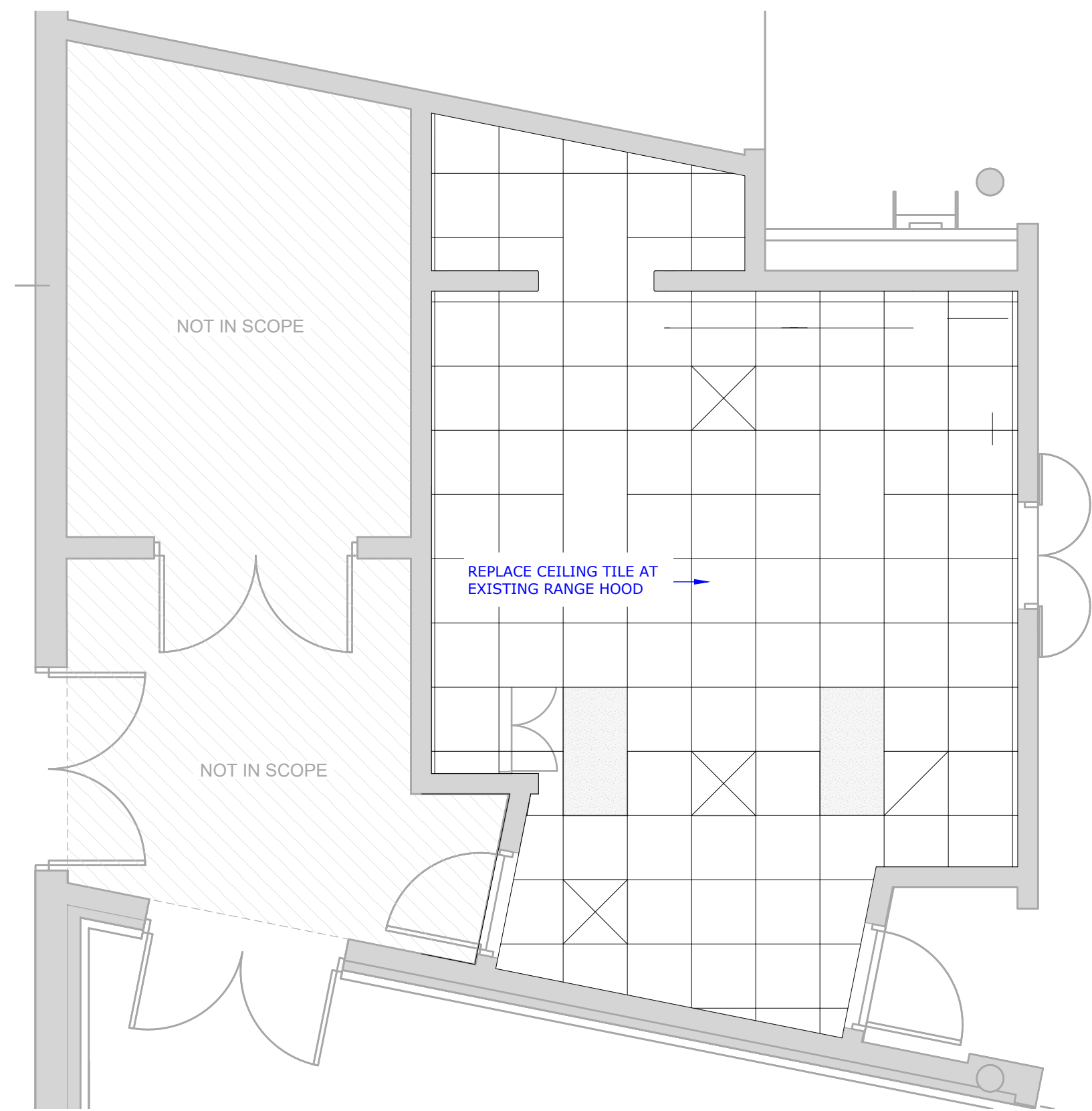

**2** REFLECTED CEILING PLAN  
 SCALE :: 1/4" = 1' - 0"

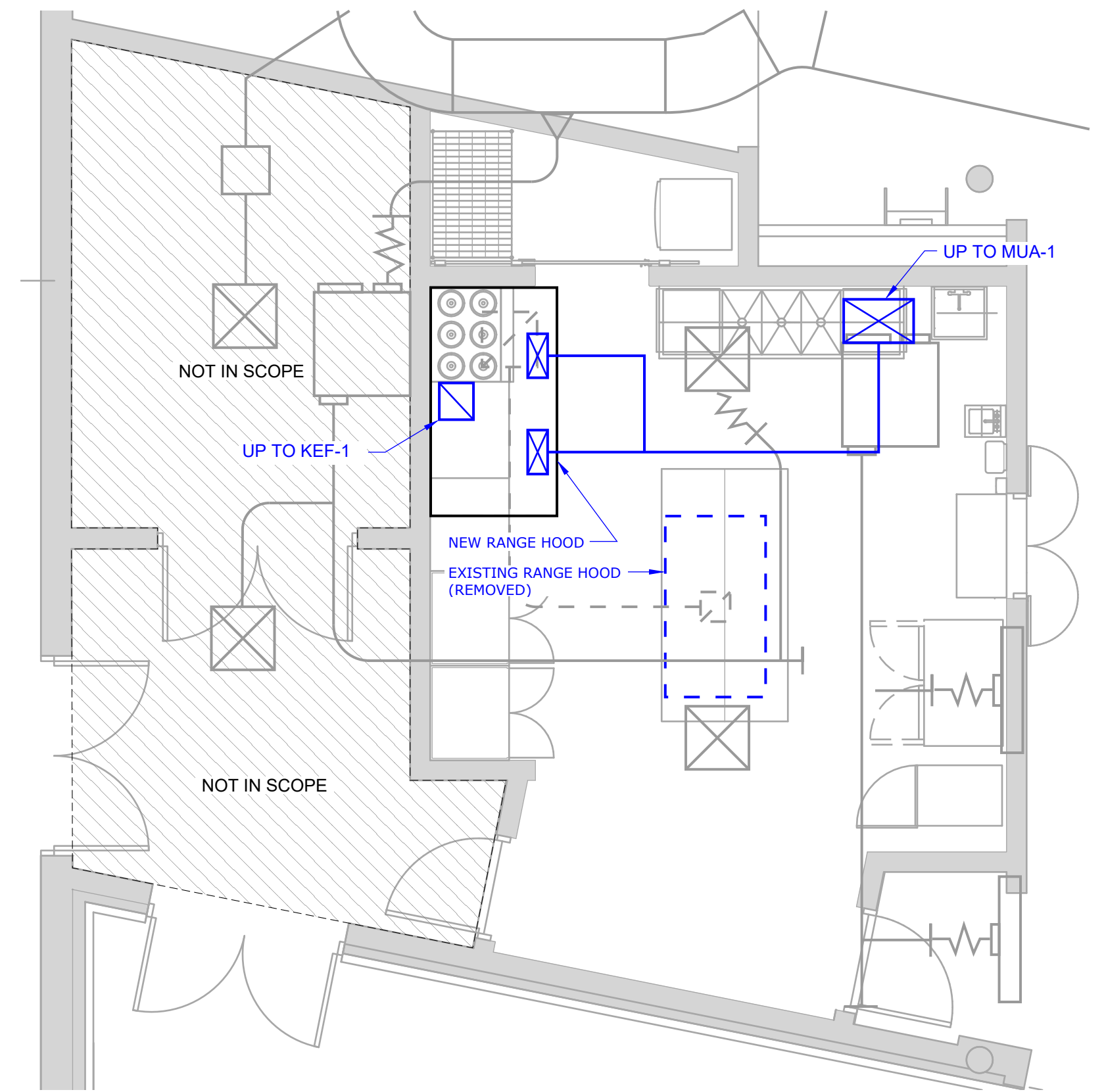

**1** MECHANICAL PLAN - DEMOLITION & NEW WORK  
 SCALE :: 1/4" = 1' - 0"



**Levy Senior Center - Kitchen Interior Remodel**

**ARCHITECT:** T. KIRKBY  
 6874 N. NW HWY  
 CHICAGO, IL 60631  
 773.225.7166

**CONTRACTOR:** TBD

**OWNER:** City of Evanston

**DOCUMENT DATE:** January 8, 2026

**DRAWN BY:** TK

**CHECKED BY:** MD

**JOB#:** 2025.01

- ▲ 8.7.2025 ISSUED FOR REVIEW
- ▲ 9.29.2025 ISSUED FOR PERMIT
- ▲ 11.20.2025 REVISION 1
- ▲ 1.8.2026 ISSUED FOR REVIEW
- ▲ 4.16.2026 ISSUED FOR BID
- ▲
- ▲
- ▲
- ▲

| TAG  | DESCRIPTION                       | CONNECTIONS (MIN) |        |      |      | REMARKS                |
|------|-----------------------------------|-------------------|--------|------|------|------------------------|
|      |                                   | DRAIN             | VENT   | CW   | HW   |                        |
| S-1  | STAINLESS STEEL HAND SINK         | 1-1/2"            | 1-1/2" | 1/2" | 1/2" | NEW                    |
| S-2  | STAINLESS STEEL PREP SINK         | 1-1/2"            | 1-1/2" | 1/2" | 1/2" | NEW                    |
| S-3  | STAINLESS STEEL TRIPLE BASIN SINK | 1-1/2"            | 1-1/2" | 1/2" | 1/2" | EXISTING               |
| FD-1 | FLOOR DRAIN                       | 4"                | 2"     | NA   | NA   | EXISTING               |
| FD-2 | FLOOR DRAIN                       | 4"                | 2"     | NA   | NA   | EXISTING               |
| IM-1 | ICE MAKER                         | 1/2"              | NA     | 1/4" | NA   | EXISTING               |
| GT-1 | GREASE TRAP                       | 4"                | 2"     | NA   | NA   | NEW, INTEGRAL CLEANOUT |
| DW-1 | DISHWASHER                        | 1"                | 1-1/2" | NA   | 1/2" | NEW                    |
| WM-1 | WASHING MACHINE                   | 2"                | 2"     | 1/2" | 1/2" | NEW                    |

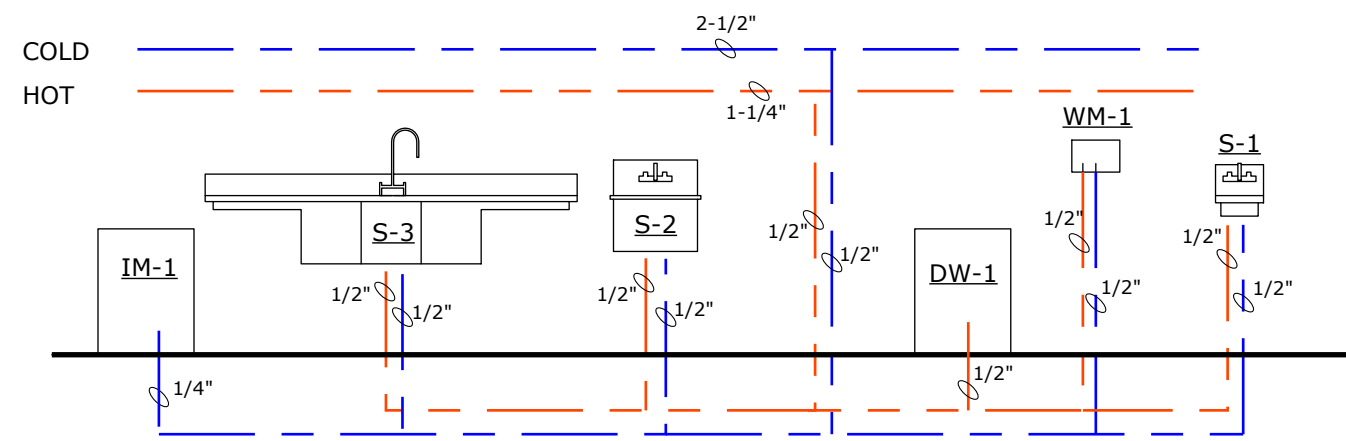
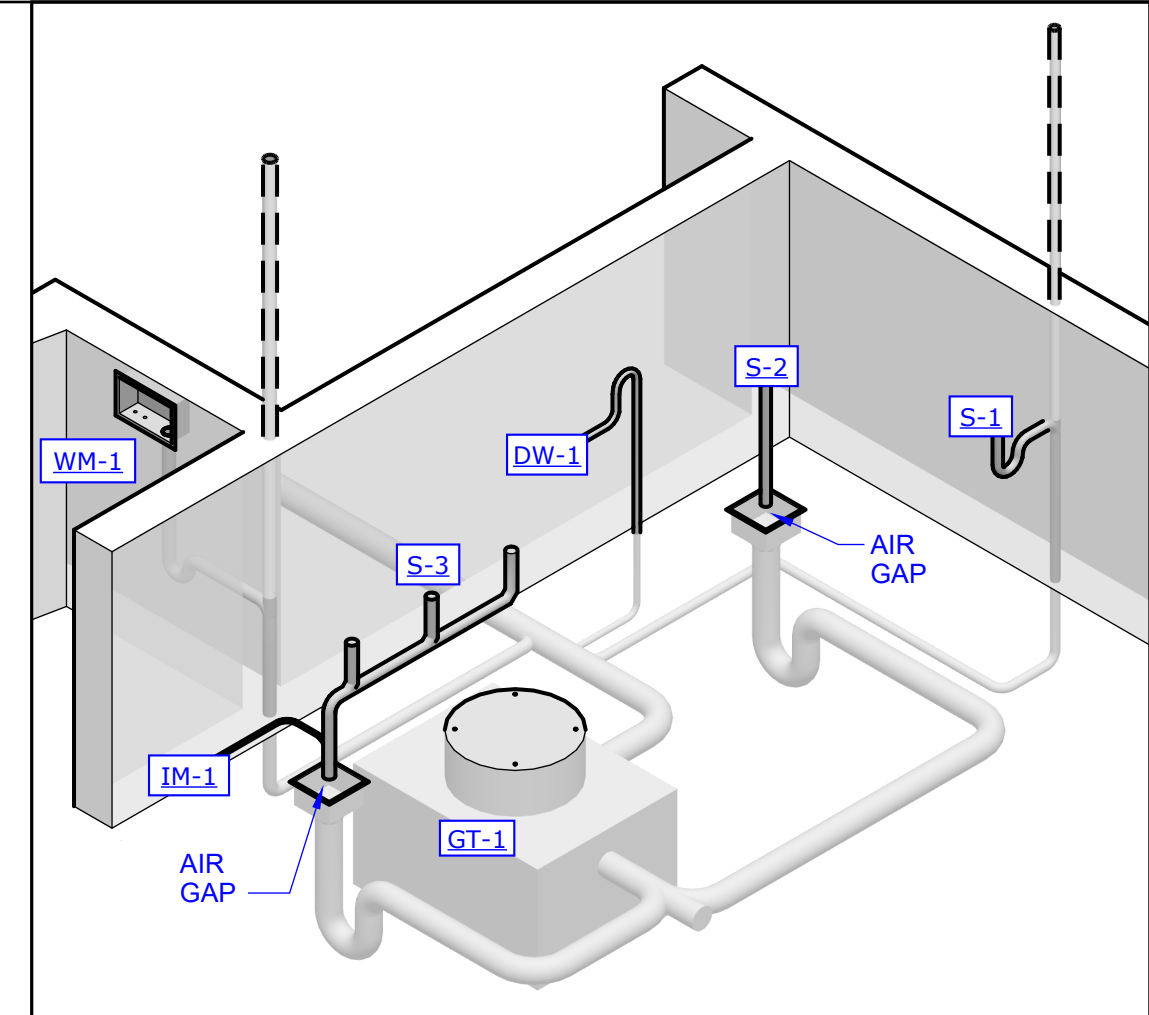

**3** PLUMBING SUPPLY DIAGRAM  
 SCALE :: 1/4" = 1' - 0"

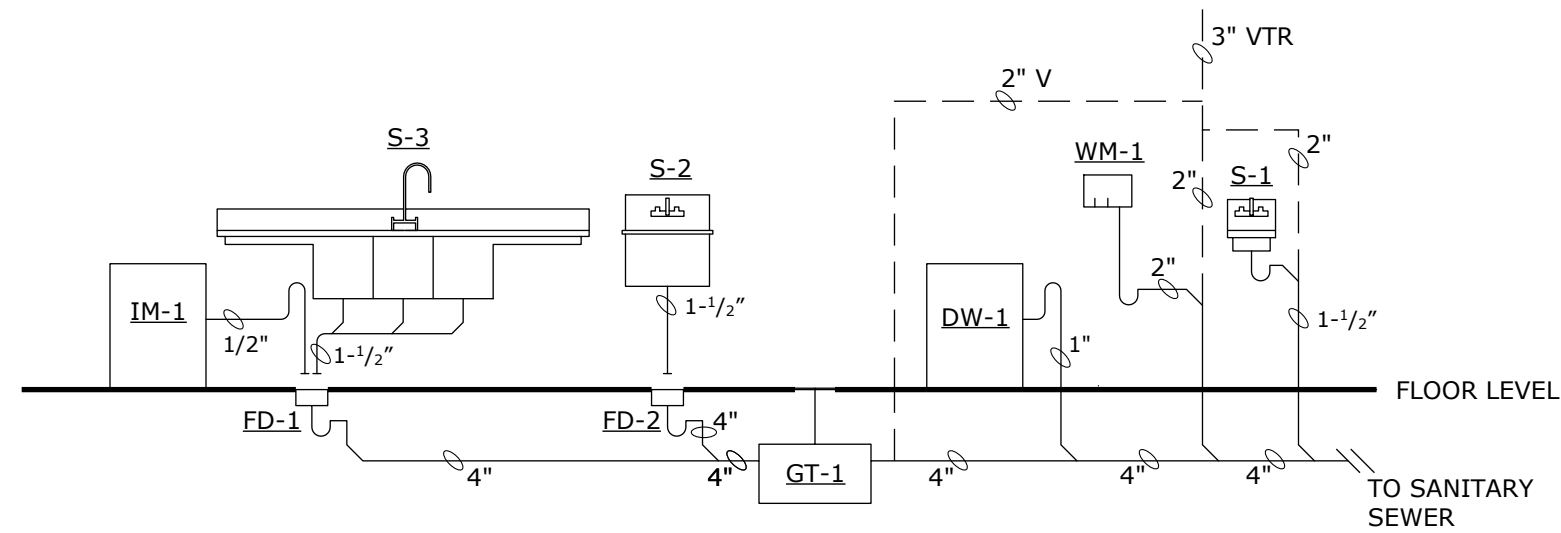

**4** PLUMBING WASTE & VENT DIAGRAM  
 SCALE :: 1/4" = 1' - 0"

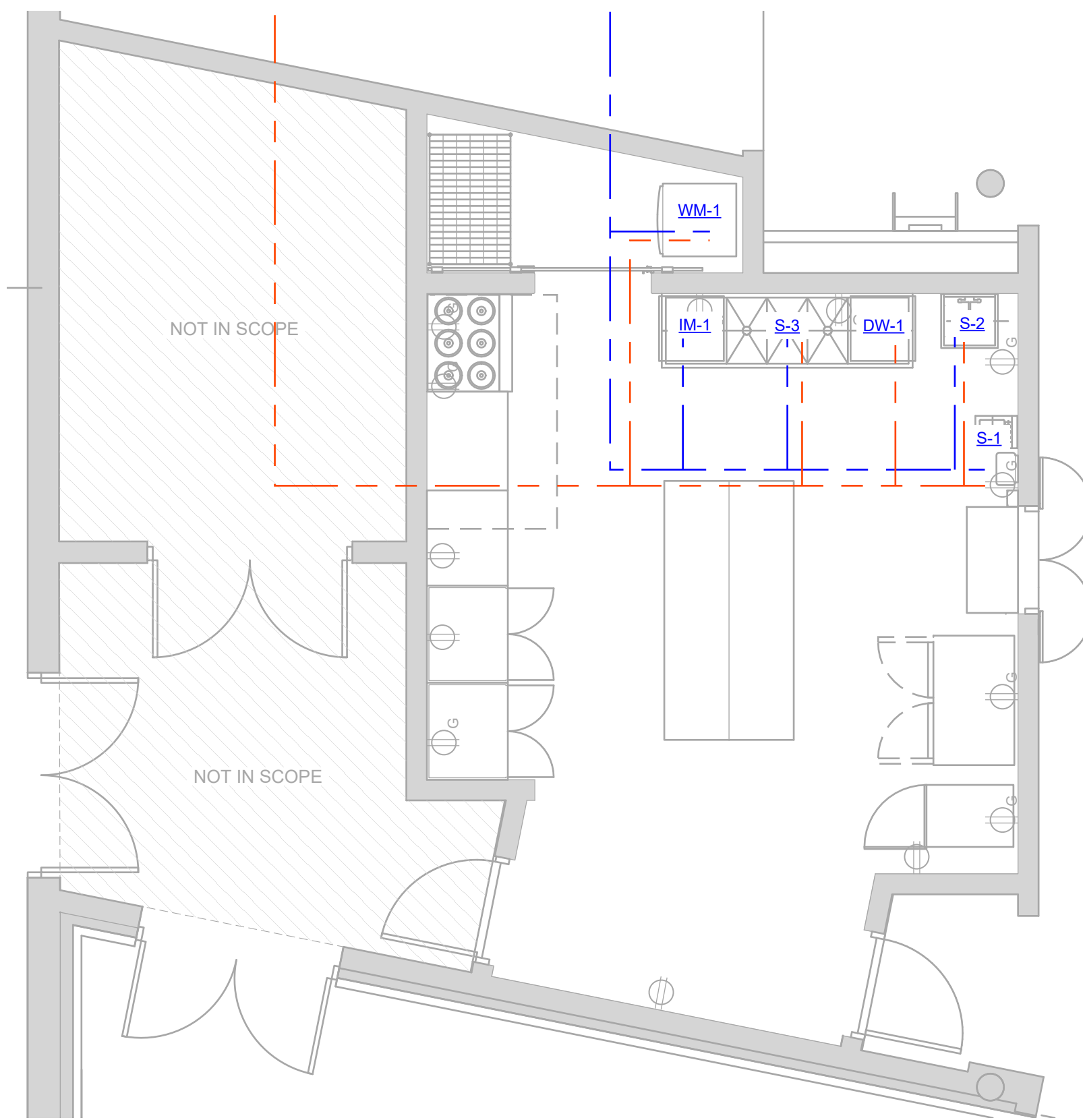

**3** PLUMBING WATER SERVICE PLAN  
 SCALE :: 1/4" = 1' - 0"

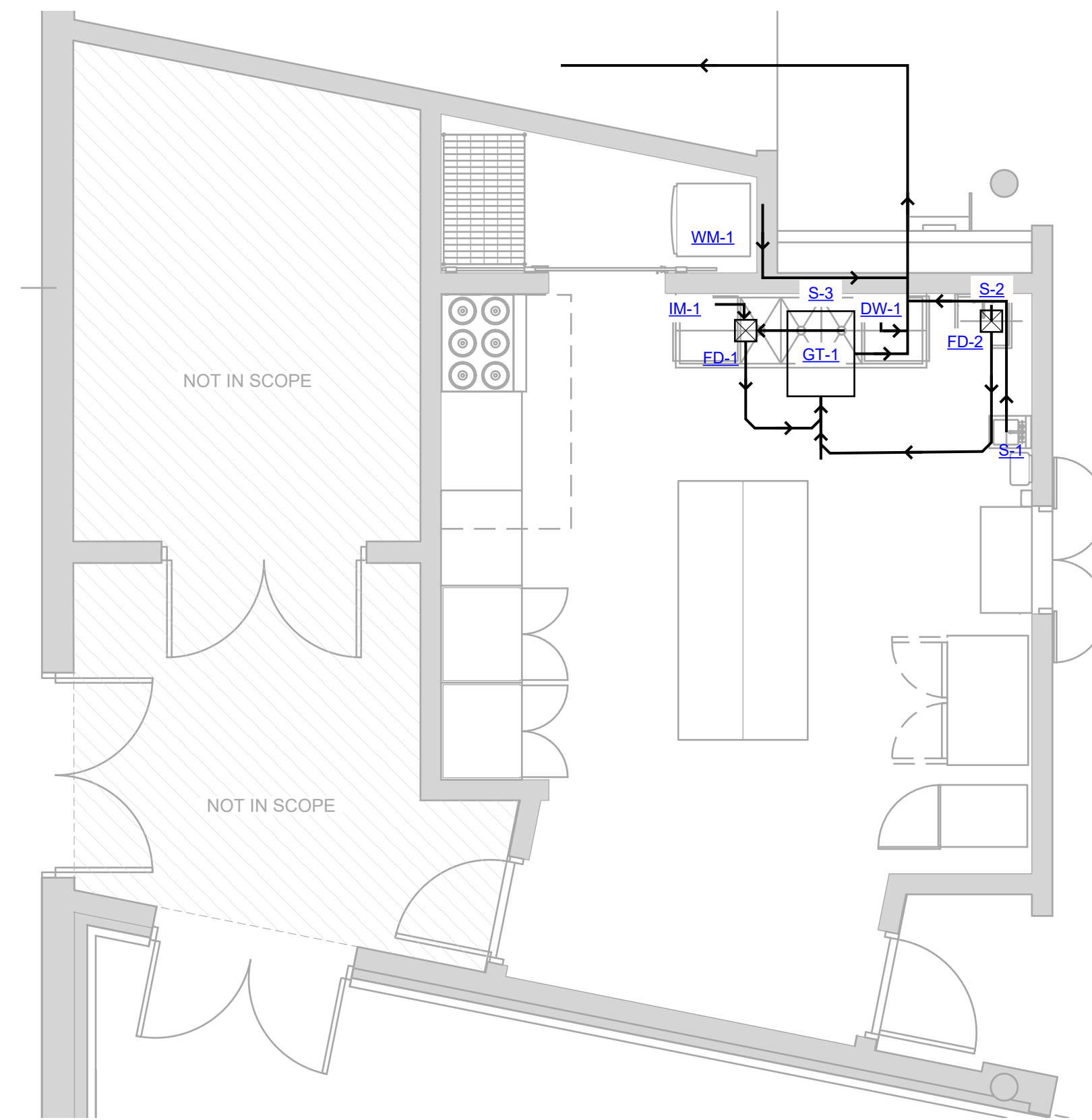









**1** PLUMBING SANITARY PLAN  
 SCALE :: 1/4" = 1' - 0"



## BID 26-27 LEVY KITCHEN REMODEL

### APPLIANCES, FIXTURES AND EQUIPMENT

| Item      | Qty         | Description                                                                                                                                                                                                                                                                                                                                                                                                                                                                                                                                                                                                      |
|-----------|-------------|------------------------------------------------------------------------------------------------------------------------------------------------------------------------------------------------------------------------------------------------------------------------------------------------------------------------------------------------------------------------------------------------------------------------------------------------------------------------------------------------------------------------------------------------------------------------------------------------------------------|
| <b>1</b>  | <b>1 ea</b> | <b>Exhaust Hood</b>                                                                                                                                                                                                                                                                                                                                                                                                                                                                                                                                                                                              |
|           |             | <p>Accurex Model No. XBEW-75.00-S</p> <p>Mark Qty Item Model Subtotal Price (USD)</p> <p>H1 1 Exhaust Only Wall Canopy Hood w/ ASP XBEW-75.00-S</p> <p>FS1 1 Fire Suppression System FSSK - 10 - 1</p> <p>FS1, Field Hook-up 1 Fire Field Hook-up FIELD HOOK-UP</p> <p>CP1 1 Accurex Kitchen Controls - Constant Volume XKC-CV-S-11-1-1-0</p> <p>KEF1 1 Exhaust Fan XCUE-130-VG</p> <p>KEF1, Roof Curb 1 Roof Curb GPFV-22-G24</p> <p>MUA1 1 Tempered Supply Fan XMSX-P109-H12-MF</p> <p>MUA1, Roof Curb 1 Roof Curb TAP-GPI</p> <p>Certification 1 Service Certification</p> <p>Start Up 1 Service Start-Up</p> |
| <b>2a</b> | <b>1 ea</b> | <b>Electric Range</b>                                                                                                                                                                                                                                                                                                                                                                                                                                                                                                                                                                                            |
|           |             |  <p>Omcan USA Model No. 49103<br/>(CE-CN-0036-ET) Commercial Range, electric, 36"W, (6) hotplates (2.6 kW &amp; 2.0 kW combination), thermostat controlled oven, 122°F (50°C) to 500°F (260°C) temperature range, pull-out crumb tray, back riser with shelf, stainless steel front, galvanized sides, adjustable legs, 18.2 kW, 208v/60/3-ph, 51 amps, cCSAus, CSA-Sanitation</p>                                                                                                                                             |
| <b>2b</b> | <b>1 ea</b> | <b>ALTERNATE Electric Range (In-Lieu of 2a)</b>                                                                                                                                                                                                                                                                                                                                                                                                                                                                                                                                                                  |
|           |             |  <p>Garland GME36M-i14C 36" Induction range with electric convection oven</p>                                                                                                                                                                                                                                                                                                                                                                                                                                                 |
| <b>3</b>  | <b>1 ea</b> | <b>Insulated Heated Holding Cabinet</b>                                                                                                                                                                                                                                                                                                                                                                                                                                                                                                                                                                          |
|           |             |  <p>Avantco HPI-1836 Full Size Insulated Heated Holding / Proong Cabinet with Clear Door - 120V</p>                                                                                                                                                                                                                                                                                                                                                                                                                           |
| <b>4</b>  | <b>1 ea</b> | <b>HUB-40 Undercounter High Temperature Dishwashing Machine</b>                                                                                                                                                                                                                                                                                                                                                                                                                                                                                                                                                  |
|           |             |  <p>American Dish Service Model No. 411-1040<br/>HUB-40 Dishmachine, undercounter, high temperature with booster</p>                                                                                                                                                                                                                                                                                                                                                                                                          |

|                                                                                     |                                                                                                                                                                                                                                                                                 |                                                      |
|-------------------------------------------------------------------------------------|---------------------------------------------------------------------------------------------------------------------------------------------------------------------------------------------------------------------------------------------------------------------------------|------------------------------------------------------|
| <b>5</b>                                                                            | <b>1 ea</b>                                                                                                                                                                                                                                                                     | <b>Crossover 2.0 Electric Stacked Washer / Dryer</b> |
|    | <p>WHLFP817MC2 - Washer<br/> DLHS0817EC2 – Electric Dryer / Stack<br/> DLHS0817-SP – Stacking Panel - required</p>                                                                                                                                                              |                                                      |
| <b>6</b>                                                                            | <b>1 ea</b>                                                                                                                                                                                                                                                                     | <b>Electric Griddle</b>                              |
|    | <p>Omcan USA Model No. 48597<br/> (CE-CN-53303F) Griddle, countertop, electric, 33.6" x 19" cooking area, chrome plated, thermostat controls, front &amp; rear grease grooves, 572°F (300°C) max temperature, stainless steel, adjustable feet, 10.8kW, 240v/60/1-ph,</p>       |                                                      |
| <b>7</b>                                                                            | <b>1 ea</b>                                                                                                                                                                                                                                                                     | <b>S-1 Stainless Steel Hand Sink</b>                 |
|   | <p>Steel Works Stainless Model No. SWHS-12-SP<br/> 20GA.304S/S Space Saver Hand Sink, Wall Mount, 15-3/4" x 12" x 13"H with 9" x 9" x 5" drawn bowl 18 GA 304S/S wall mounted clip 18GA 304S/S side splashes Gooseneck faucet FW-4-4GLL included 1.5" drain basket included</p> |                                                      |
| <b>8</b>                                                                            | <b>1 ea</b>                                                                                                                                                                                                                                                                     | <b>S-2 Stainless Steel Prep Sink</b>                 |
|  | <p>Steelton 24" 18-Gauge Stainless Steel One Compartment Commercial Sink with Faucet - 18" x 18" x 12" Bowl</p>                                                                                                                                                                 |                                                      |
| <b>9</b>                                                                            | <b>1 ea</b>                                                                                                                                                                                                                                                                     | <b>Stainless Steel Work Table with Enclosed Base</b> |
|  | <p>Advance Tabco CB-SS-248M 96" Enclosed Work Table w/ Sliding Doors &amp; Midshelf, 24"D. TA-46 Door locks on right and left, TA-12 Countertop Edge.</p>                                                                                                                       |                                                      |
| <b>10</b>                                                                           | <b>1 ea</b>                                                                                                                                                                                                                                                                     | <b>Stainless Steel Work Table with Enclosed Base</b> |
|  | <p>Advance Tabco CF-SS-306 30" x 72" 14 Gauge Work Table with Cabinet Base and 1 1/2" Backsplash, TA-46 Door lock, TA-12 Countertop Edge.</p>                                                                                                                                   |                                                      |

**11 2 ea Stainless Steel Pantry Cabinets**



Freestanding stainless steel storage cabinet, 72" H x 36" W x 30" D. Cabinet shall be constructed of Type 304 stainless steel with minimum 18-gauge body and reinforced doors. Provide lockable, hinged doors with stainless steel handles and integral lockset. Interior shall include fully adjustable stainless steel shelves supported on adjustable shelf clips. Cabinet shall have smooth, sanitary finish with all welded and ground seams. Provide adjustable stainless steel bullet feet for leveling. Unit shall be suitable for commercial kitchen use

**12 1 ea Grease Trap**



GB3 50 GPM Great Basin Indoor Grease Interceptor

| HOOD INFORMATION |      |                               |                       |       |              |                        |                            |           |            |          |             |           |          |      |                     |                  |        |
|------------------|------|-------------------------------|-----------------------|-------|--------------|------------------------|----------------------------|-----------|------------|----------|-------------|-----------|----------|------|---------------------|------------------|--------|
| HOOD NO.         | MARK | MODEL                         | HOOD DIMENSIONS (IN.) |       |              | HOOD CONSTR.           | COOKING LOAD / DUTY RATING | EXHAUST   |            |          |             |           | SUPPLY   |      | HANGING WEIGHT LBS. | SECTION LOCATION |        |
|                  |      |                               | LENGTH                | WIDTH | HEIGHT       |                        |                            | TOTAL CFM | COLLAR(S)  |          |             | MUA CFM   | AC CFM   |      |                     |                  |        |
|                  |      | FIXTURE TYPE BULB / LAMP INFO |                       | QTY   | FOOT CANDLES | TYPE / MODEL MATERIAL  |                            | QTY       | SIZE (IN.) | LOCATION | FIRE SYSTEM |           | CONTROLS |      |                     |                  |        |
| 1                | H1   | XBEW-75-S                     | 75                    | 48    | 24           | 430 SS WHERE EXPOSED   | HEAVY                      | 1350      | 10         | 12       |             | 1350      | 0.446    | 1080 |                     | 312              | SINGLE |
| 1                | H1   |                               | ROUND LED             | 2     | 70.87        | BAFFLE STAINLESS STEEL |                            | 2         | 16         | 20       | LEFT        | AMEREX KP | 3.75     | XKC  |                     |                  |        |

| HOOD INFORMATION |      |                               |  |     |                           |                        |  |                    |            |          |             |           |          |     |  |  |  |
|------------------|------|-------------------------------|--|-----|---------------------------|------------------------|--|--------------------|------------|----------|-------------|-----------|----------|-----|--|--|--|
| HOOD NO.         | MARK | LIGHTING DETAILS              |  |     | GREASE FILTRATION DETAILS |                        |  | UTILITY CABINET(S) |            |          |             |           |          |     |  |  |  |
|                  |      | FIXTURE TYPE BULB / LAMP INFO |  | QTY | FOOT CANDLES              | TYPE / MODEL MATERIAL  |  | QTY                | SIZE (IN.) | LOCATION | FIRE SYSTEM |           | CONTROLS |     |  |  |  |
| 1                | H1   | ROUND LED                     |  | 2   | 70.87                     | BAFFLE STAINLESS STEEL |  | 2                  | 16         | 20       | LEFT        | AMEREX KP | 3.75     | XKC |  |  |  |

| SUPPLY PLENUM INFORMATION |      |       |      |            |    |   |           |           |              |     |           |            |         |          |     |    |    |      |     |      |
|---------------------------|------|-------|------|------------|----|---|-----------|-----------|--------------|-----|-----------|------------|---------|----------|-----|----|----|------|-----|------|
| HOOD NO.                  | MARK | POS.  | TYPE | SIZE (IN.) |    |   | INSULATED | DAMPER(S) | LED LIGHT(S) |     | TOTAL CFM | TOTAL S.P. | COLLARS |          |     |    |    |      |     |      |
|                           |      |       |      | L          | W  | H |           |           | SUPPLIED     | QTY |           |            | TYPE    | MOUNTING | QTY | W  | L  | DIA. | CFM | VEL. |
| 1                         | H1   | FRONT | ASP  | 87         | 14 | 4 | NO        | YES       | NO           |     | 1080      | 0.02       | MUA     | FACTORY  | 2   | 10 | 24 |      | 540 | 324  |

**HOOD OPTIONS**

UL 710 LISTED W/ OUT EXHAUST FIRE DAMPER - UL #R25625  
 BACK INTEGRAL AIR SPACE - 3 IN WIDE  
 FACTORY MOUNTED EXHAUST COLLAR(S)  
 LEFT INSULD END PNL W/ ADJ LEG 78.00 IN HIGH 27.00 IN TOP WIDTH 21.0 IN BOTTOM WIDTH  
 RIGHT INSULD END PNL W/ ADJ LEG 78.00 IN HIGH 27.00 IN TOP WIDTH 21.0 IN BOTTOM WIDTH  
 BACKSPLASH 78.00 IN HIGH 87.00 IN LONG  
 PERFORMANCE ENHANCING LIP (PEL) TECHNOLOGY  
 STANDING SEAM CONSTRUCTION FOR SUPERIOR STRENGTH

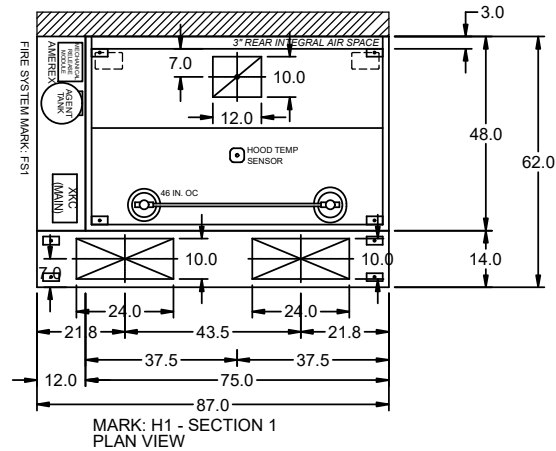

FIRE (PIPING/DROPS/NOZZLES/ETC.)  
 SUBJECT TO CHANGE. AS-BUILT  
 DRAWINGS CAN BE PROVIDED AT  
 TIME OF ORDER AND INCLUDED  
 WITH PRODUCT SHIPMENT

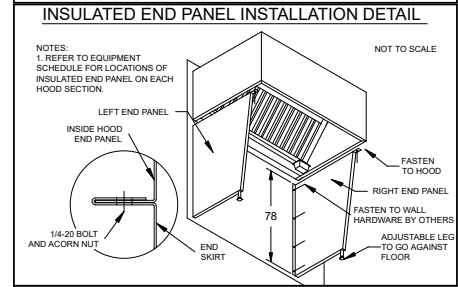
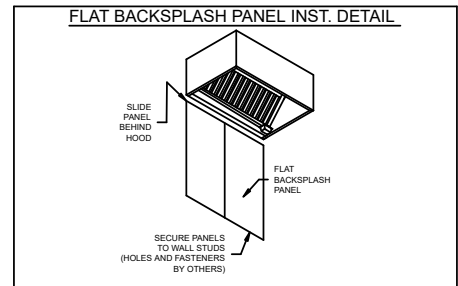
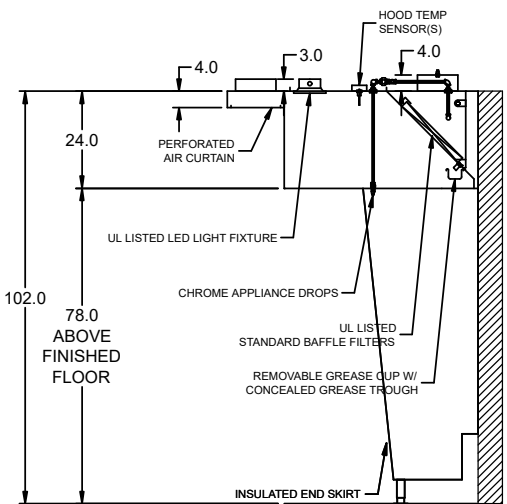
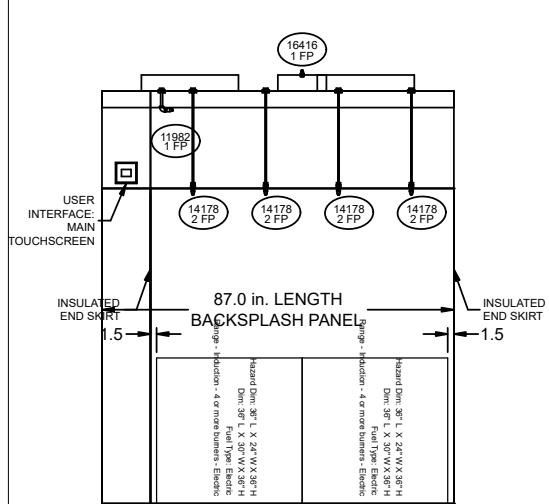

**HOOD HANGING HEIGHT FOR FIRE SYSTEMS**  
 VERIFICATION OF HOOD HANGING HEIGHT ABOVE FINISHED FLOOR (A.F.F.) IS REQUIRED FOR CORRECT PLACEMENT OF FIRE SYSTEM NOZZLES.

RECOMMENDED HANGING HEIGHT = 78" FROM FINISHED FLOOR TO LOWER FRONT EDGE OF HOOD.

OTHER HANGING HEIGHT = \_\_\_\_\_" FROM FINISHED FLOOR TO LOWER EDGE OF HOOD.

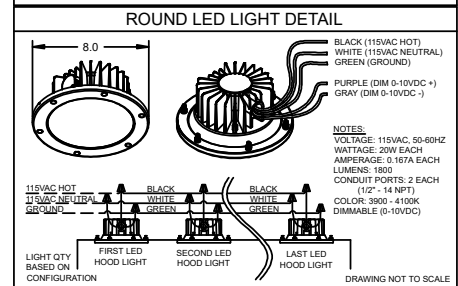
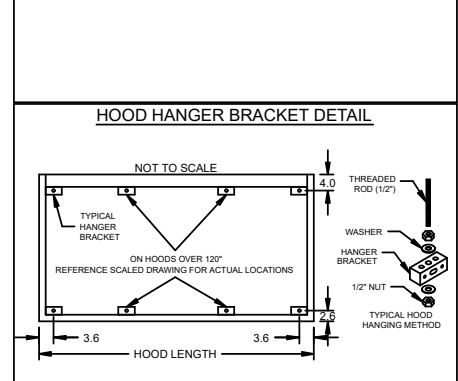
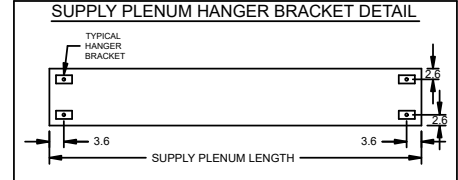

FIRE SYSTEM INFORMATION

| MARK | MODEL                  | LOCATION                 | FLOW POINTS                 |     | SUPPLY LINE | DETECTION    | MARK(S) PROTECTED BY FIRE SYSTEM |
|------|------------------------|--------------------------|-----------------------------|-----|-------------|--------------|----------------------------------|
|      |                        |                          | HOODS                       | PCU |             |              |                                  |
| FS1  | AMEREX KP WET CHEMICAL | CABINET – LEFT END OF H1 | 10 UTILIZED<br>11 AVAILABLE |     | CONTINUOUS  | FUSIBLE LINK | H1 SECTION 1                     |

FIRE SYSTEM OPTIONS AND ACCESSORIES

FULL INSTALLATION (INCLUDES PRE-PIPED HOOD(S) WITH DETECTION AND FACTORY COORDINATED INSTALL)  
 CHROME SLEEVES FOR FACTORY PROVIDED APPLIANCES DROPS - INCLUDED  
 METAL BLOW-OFF CAPS - INCLUDED  
 HOOD SUPPRESSION TANK - INCLUDED - 3.75 GAL. - [(1) 3.75 TANK(S)]  
 REMOTE PULL STATION - STANDARD - FIELD INSTALLATION AT SINGLE POINT OF EGRESS

AMEREX KP (WET CHEMICAL) FIRE PROTECTION SYSTEM - MODEL FSSK

### CONTROL PANEL

1. MRM (MECHANICAL RELEASE MODULE)  
 2. NITROGEN ACTUATION CYLINDER  
 3. MICROSWITCH

NOT TO SCALE

### WIRING DIAGRAM FOR MICRO SWITCHES

SWITCH RATING:  
 21A 120/250V75°C  
 1HP 120/250V75°C  
 2HP 250V75°C

BOTH UPPER AND LOWER SWITCH(ES)

NOTES:

WET CHEMICAL FIRE PROTECTION SYSTEM TO BE AMEREX KP, DESIGNED IN COMPLIANCE WITH UL 300 REQUIREMENTS.  
 -VERIFICATION OF ALL COOKING EQUIPMENT MAKE, MODEL AND LOCATION REQUIRED FOR ALL FIRE PROTECTION SYSTEMS.  
 -ALL FIRE SYSTEM PIPING IS STANDARDLY TO THE RIGHT END OF THE HOOD UNLESS A WALL IS LOCATED ON THE RIGHT END.  
 -AMEREX MRM/PRM TO BE LOCATED WITHIN 60" OF HOOD.

THE BASIC FIRE SYSTEM WILL INCLUDE THE FOLLOWING:  
 -GAS SHUT-OFF VALVE, IF REQUIRED, TO BE SUPPLIED BY MANUFACTURER (UP TO 2" DIAMETER AS STANDARD), AND INSTALLED BY A LICENSED PLUMBER.  
 -MICRO SWITCH TO BE SUPPLIED BY MANUFACTURER FOR CONNECTION TO, BUT NOT LIMITED TO, BUILDING ALARM SYSTEM(S), EXHAUST AND SUPPLY FANS AND ELECTRICAL POWER SHUT DOWN. FIELD WIRING AND CONNECTIONS TO BE PERFORMED BY A LICENSED ELECTRICIAN.  
 -THREE TRIPS TO THE JOBSITE  
 -ANY STATE OR LOCAL INSTALLATION PERMITS.

THE BASIC FIRE SYSTEM DOES NOT INCLUDE THE FOLLOWING:  
 -FULL DUMP TEST OTHER THAN WHAT IS SPECIFIED PER THE INSTALLATION MANUAL OR TO SATISFY A STATE OR LOCAL CODE.  
 -MORE THAN THREE TRIPS TO THE JOBSITE OR SPECIAL TRANSPORTATION, OR OVERNIGHT LODGING REQUIREMENTS IN REMOTE AREAS. NORMAL TRAVEL DISTANCE IS FIRST 50 MI. (80.5 KM) FROM OFFICE.  
 -SPECIAL CLASSES OR ADDITIONAL LABOR FOR ACCESS TO SECURITY SENSITIVE AREAS.  
 -INSTALLATION OF GAS SHUT-OFF VALVE.  
 -SPECIAL DRAWINGS REQUIRED TO SATISFY STATE OR LOCAL CODE.  
 -UNION LABOR, GOVERNMENT LABOR, OR PREVAILING WAGES REQUIRED FOR FINAL FIELD HOOK-UP.  
 -ANY AND ALL ELECTRICAL COMPONENTS/CONNECTIONS REQUIRED TO SHUT DOWN FANS, SHUT OFF DEVICE FOR ELECTRIC COOKING EQUIPMENT (SHUNT TRIP BREAKER), OR ACTIVATE AN ALARM SYSTEM, ETC.  
 -ANY DISMANTLING OR REASSEMBLY REQUIRED TO GAIN ACCESS TO THE FIRE SUPPRESSION PIPING LOCATED ON THE TOP OF THE HOOD.  
 -PLAN EXAMINATION FEES, PE OR FPS APPROVAL STAMP.  
 -ROUGH-IN CONDUIT FOR REMOTE PULL STATION OR GAS VALVE (FOR FLUSH MOUNTED PULL STATION).  
 -INSTALLATION OF MORE THAN (1) REMOTE PULL STATIONS OR DISTANCES GREATER THAN 20 FT. (6.1M).  
 -PARTS OR LABOR REQUIRED TO CORRECT PIPING DUE TO COOKING EQUIPMENT CHANGES OR DEVIATION FROM PLANS, OR ANY CHARGES FOR MISSING OR ADDITIONAL PARTS OTHER THAN THOSE INDICATED ON THE FIRE SUPPRESSION DETAIL.

CONNECTION TO BUILDINGS ALARM

CONNECTION TO KC (PCB) CONTROL PANEL

NOTES:  
 1 - - - - - DENOTES FIELD INSTALLATION.  
 2 - - - - - DENOTES FACTORY INSTALLATION.

ACCUREX NORTHERN IL  
 RAY SCHMIDT  
 RAY.SCHMIDT@ACCUREX.COM  
 (815)566-9619

PROJECT  
 5/13/2025

MARK  
 FS1

EVANSTON LEVY SENIOR CENTER

CONTROL INFORMATION

| MARK | MAIN ELECTRICAL CONTROL PACKAGE |                    | MAIN USER INTERFACE    |                              | FANS CONTROLLED |         |     |          |      |      |          |            |       |             |                        |              |
|------|---------------------------------|--------------------|------------------------|------------------------------|-----------------|---------|-----|----------|------|------|----------|------------|-------|-------------|------------------------|--------------|
|      | MODEL                           | LOCATION           | TYPE                   | LOCATION                     | FAN #           | TYPE    | FAN | FAN MARK | ZONE | CFM  | MOTOR HP | MOTOR VOLT | CYCLE | MOTOR PHASE | MOTOR STARTER IN PANEL | VFD IN PANEL |
| CP1  | XKC-CV-S-11-1-1-0               | LEFT CABINET ON H1 | FULL COLOR TOUCHSCREEN | CABINET - LEFT CABINET ON H1 | 1               | EXHAUST | E1  | KEF1     | 1    | 1350 | 0.75     | 115        | 60    | 1           | NO                     | NO           |
|      |                                 |                    |                        |                              | 2               | SUPPLY  | S1  | MUA1     | 1    | 1080 | 0.5      | 460        | 60    | 3           | NO                     | NO           |

CONTROL FEATURES

- HOOD LIGHT CONTROL
- TEMP SENSORS (FACTORY INSTALLED) - QTY. 1
- DRY FIRE CONTACTS - QTY. 1
- LIGHTS OFF DURING FIRE
- EXHAUST MAX DURING FIRE
- SUPPLY OFF DURING FIRE

**CABINET DETAILS**

DRAWING NOT TO SCALE

**MOUNTING LOCATION:**  
UTILITY CABINET ON HOOD  
(INNER CONTROL BOX: 12 X 20 X 6)

**NOTES:**  
1) WHEN CONTROLS ARE MOUNTED IN HOOD-MOUNTED OR WALL-MOUNTED UTILITY CABINET, FOR HOOD OR WALL CABINET DIMENSIONS SEE HOOD SUBMITTAL.  
2) MINIMUM OF 36" OF CLEARANCE RECOMMENDED IN FRONT OF CONTROL CABINET

**MAIN USER INTERFACE DETAILS**

**MOUNTING TYPE:**  
FACTORY MOUNTED:  
UTILITY CABINET - LEFT END OF HOOD

**USER INTERFACE CONTROL:**  
FANS AND LIGHTS

**INTERFACE CABLE LENGTH:**  
7FT (FACTORY PROVIDED)

DOC NUMBER: --- REV: ---

**CAUTION**  
UNIT MUST BE GROUNDED IN ACCORDANCE WITH N.E.C. POWER MUST BE OFF WHILE SERVICING.

**ATTENTION**  
L'APPAREIL DOIT ÊTRE MIS À LA TERRE CONFORMÉMENT AU CODE C.E. L'ALIMENTATION DOIT ÊTRE COUPÉE DURANT L'ENTRETIEN.

COMMERCIAL APPLIANCE OUTLET CENTER  
ELECTRICAL RATINGS: 110-240V, 1PHASE, 50-60HZ, 15A  
BASE FILE #E200616, ML FILE #E313951

THESE DRAWINGS SHALL NOT BE REMOVED FROM THIS EQUIPMENT. USE COPPER CONDUCTORS RATED TO 90°C UNLESS SPECIFIED. TORQUE CONTROL & GROUND BLOCKS TO 8 LBS. IN. TORQUE POWER LUGS/SCREWS TO COMPONENT RATINGS LISTED. TORQUE CONTROL BOARD SCREW TERMINALS TO 3.5 LBS. IN. FIELD CONTROL WIRING RESISTANCE SHOULD NOT EXCEED 0.75 OHM. SEE IOM FOR ADDITIONAL INFORMATION, OR CALL FACTORY AT 1-800-371-8858.

NE PAS RETIRER CES DESSINS DE CET ÉQUIPEMENT SAUF INDICATION CONTRAIRE. UTILISER DES CONDUCTEURS EN CUIVRE CLASSÉS 90 °C. SERRER LES BORNES DE COMMANDE ET DE MISE À LA TERRE À 8 LB-PO. SERRER LES COSSÉS/VIS D'ALIMENTATION AUX COUPLES INDICQUÉS POUR LE COMPOSANT. SERRER LES BORNES À VIS DE LA CARTE DE COMMANDE À 3.5 LB-PO. LA RÉSISTANCE DU CÂBLAGE DE COMMANDE LOCAL NE DOIT PAS DÉPASSER 0.75 OHM. POUR PLUS D'INFORMATION, CONSULTEZ LE MANUEL OU APPELEZ 1-800-371-8858.

WIRING DIAGRAM CODE: WDC#  
JOB NAME: EVANSTON LEVY SENIOR CENTER  
MODEL: XKC-CV-S-11-1-1-0  
SERIAL NUMBER: WDSN#  
MARK: CP1

**POWER WIRING FOR KITCHEN CONTROLS**  
(WIRING TO BE DONE BY ELECTRICIAN)

**POWER WIRING FROM BREAKER PANEL DIRECT TO FANS**  
(WIRING TO BE DONE BY ELECTRICIAN)

**CONTROL WIRING FOR KITCHEN CONTROLS**  
(WIRING TO BE DONE BY ELECTRICIAN, IF NO CONTROLS CONTRACTOR. USE 18-22GA WIRE UNLESS SPECIFIED.)

**FACTORY SETTINGS**  
TYPE: CV  
CONFIGURATION: STANDARD  
ZONES: 1  
HOODS: 1  
EXHAUST FANS: 1  
SUPPLY FANS: 1  
MB ROOM SENSOR: NO  
MB TEMP SENSORS: 1  
HIGH TEMP FAULT: NO  
FREEZE PROTECTION: YES  
MB GAS RESET: NO  
FAN PROVING: NO  
BMS: NONE

**EXHAUST FAN SETTINGS**  
SEE FAN CONFIGURATION TABLE BELOW

**SUPPLY FAN SETTINGS**  
SEE FAN CONFIGURATION TABLE BELOW

**SENSOR SETTINGS**  
SEE HOOD CONFIGURATION TABLE BELOW

**USER INTERFACE SETTINGS (MB)**  
FAN & LIGHT BUTTONS: SHOW BOTH (SEPERATE)

**GENERAL SETTINGS**  
TIME ZONE: CENTRAL DAYLIGHT (DEFAULT)

**MB FIRE/FAULT SETTINGS**  
EXHAUST DURING FIRE: MAX  
SUPPLY DURING FIRE: OFF  
LIGHTS DURING FIRE: OFF

**ZONE CONFIGURATION**

| ZONE # | ZONE | ROOM TEMP |
|--------|------|-----------|
| 1      | Z1   | PRESET    |

**HOOD CONFIGURATION**

| HOOD # | HOOD | HOOD MARK    | ZONE | EXH A | EXH B | SUPPLY | MB TEMP SENSORS |
|--------|------|--------------|------|-------|-------|--------|-----------------|
| 1      | H1   | H1 SECTION 1 | Z1   | E1    | -     | S1     | TS1             |

**FAN CONFIGURATION**

| FAN # | TYPE    | FAN | FAN MARK | ZONE | MIN CFM | MAX CFM | MODBUS VFD | VFD ADDRESS | MIN FREQ | MAX FREQ | MIN VDC | MAX VDC |
|-------|---------|-----|----------|------|---------|---------|------------|-------------|----------|----------|---------|---------|
| 1     | EXHAUST | E1  | KEF1     | Z1   | -       | 1350    | NO         | -           | -        | -        | -       | 9.1     |
| 2     | SUPPLY  | S1  | MUA1     | Z1   | -       | 1080    | NO         | -           | -        | -        | -       | 10.0    |

**\*FIRE SYSTEM DRY CONTACT WIRING EXAMPLES**

DO NOT USE CONTACTS FOR PROVIDING SIGNALS TO BUILDING FIRE ALARM. DRY CONTACTS SWITCH STATE DURING POWER LOSS TO PANEL.

SHUNT TRIP (BY OTHERS) WIRING EXAMPLE:  
COMMON (C1) NORMALLY OPEN (NOT) SHUNT TRIP BREAKER COIL

APPLIANCE CONTACTORS (BY OTHERS) WIRING EXAMPLE:  
COMMON (C1) NORMALLY CLOSED (NCT) APPLIANCE CONTACTOR COIL

EVANSTON LEVY SENIOR CENTER

PROJECT: 5/13/2025

ACCUREX NORTHERN IL  
RAY SCHMIDT  
RAY.SCHMIDT@ACCUREX.COM  
(815)566-9619

ACCUREX



CP1

MARK

Direct Drive Upblast Centrifugal Roof Exhaust Fan

| MARK INFORMATION |     | FAN INFORMATION |            |              |                      |                            |                 |                          |     |                   | SOUND INFORMATION |             |                         |            |              | MOTOR INFORMATION    |                 |                      |           |         |       |       |           |          |
|------------------|-----|-----------------|------------|--------------|----------------------|----------------------------|-----------------|--------------------------|-----|-------------------|-------------------|-------------|-------------------------|------------|--------------|----------------------|-----------------|----------------------|-----------|---------|-------|-------|-----------|----------|
| MARK             | QTY | MODEL           | DRIVE TYPE | VOLUME (CFM) | EXTERNAL SP (IN. WG) | TOTAL EXTERNAL SP (IN. WG) | FAN SPEED (RPM) | OUTLET VELOCITY (FT/MIN) | FEI | TOTAL WEIGHT (LB) | INLET dBA         | INLET SONES | INLET SONES (SPHERICAL) | OUTLET dBA | OUTLET SONES | OPERATING POWER (HP) | MOTOR SIZE (HP) | FEP INPUT POWER (KW) | ENCLOSURE | VOLTAGE | CYCLE | PHASE | EC MOTOR  | NEC FLA* |
| KEF1             | 1   | XCUE-130-VG     | Direct     | 1,350        | 1.1                  | 1.1                        | 1,569           | 1,054.69                 | 0   | 78.6              | 63.8              | 13.09       | 0                       | 0          | 0            | 0.41                 | 0.75            | 0                    | OP        | 115     | 60    | 1     | VariGreen | 13.8     |

\*NEC FLA - Based on table 430.250 or 430.248 of National Electrical Code 2020. Actual motor FLA may vary for sizing thermal overload, consult factory"

KEF1 : SELECTED OPTIONS AND ACCESSORIES

Motor VFD Rated without Shaft Grounding Protection  
 One piece fully welded windband  
 Tapered bushing wheel hub  
 Breather tube outlet area min. 4.4 sq. in. (sizes 99-480), 2.0 sq. in. (sizes 60-95)  
 Min. windband material thickness: 0.051" aluminum (060-240), 0.064" aluminum (240HP, 240XP), 0.080" aluminum (sizes 300-480)  
 Larger Curb Cap Size - 22 Square  
 UL/cUL 705 Listed - Supplement SC - "Power Ventilators for Restaurant Exh. Appliances" (Formerly UL 762)  
 Switch, NEMA-3R, Toggle,  
 Hinge, Factory Installed  
 High Temp Curb Seal Rated for Continuous Duty at 1500 F (Factory Attached)  
 Fastener Material: Stainless  
 Grease Trap (PN 475538)  
 Aluminum Wheel Material

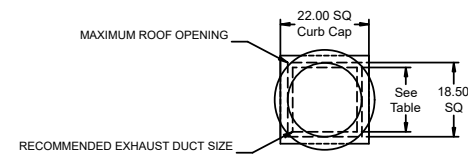

| DUCT TYPE    | SIZE  |
|--------------|-------|
| STANDARD     | 16 SQ |
| FIRE-WRAPPED | 8 SQ  |

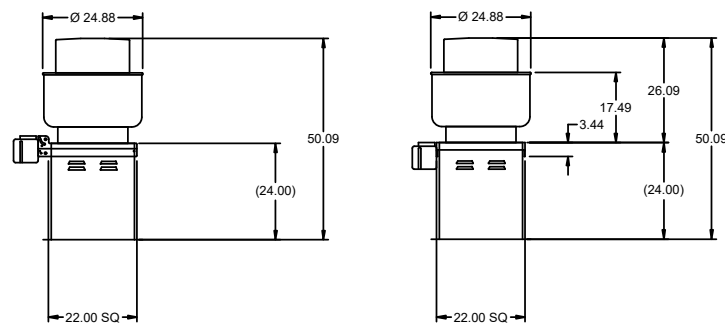

DUCT DIMENSIONS ARE LARGEST POSSIBLE DUCT TO FIT THROUGH CURB.  
 CONSULT SYSTEM DESIGN ENGINEER FOR RECOMMENDED DUCT SIZE.

OVERALL HEIGHT MAY BE GREATER DEPENDING ON  
 MOTOR, ADAPTER, AND/OR HINGE BASE.

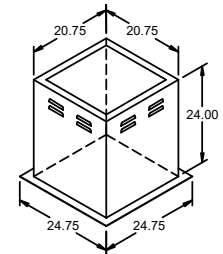

EVANSTON LEVY SENIOR CENTER

PROJECT 5/13/2025

ACCUREX NORTHERN ILL  
 RAY SCHMIDT  
 RAY.SCHMIDT@ACCUREX.COM  
 (815)666-9619



MARK KEF1

| EQUIPMENT SCHEDULE                |                  |             |                            |              |                 |                |        |          |            |        |            |      |
|-----------------------------------|------------------|-------------|----------------------------|--------------|-----------------|----------------|--------|----------|------------|--------|------------|------|
| Tempered Make-Up Air Unit         |                  |             |                            |              |                 |                |        |          |            |        |            |      |
| Qty                               | Accurex Model    | Volume      | External SP                | Total SP     | MCA             | MOP            | Weight | SCCR     | Mark: MUA1 |        |            |      |
| 1                                 | XMSX-P109-H12-MF | 1,080 CFM   | 0.5 in. wg                 | 0.649 in. wg | 40.8            | 45             | 944 lb | 5kA      |            |        |            |      |
| Motor Information                 |                  |             |                            |              |                 |                |        |          |            |        |            |      |
| Size                              | VICP             | Enclosure   | Motor with Shaft Grounding | Motor RPM    | Operating Power |                |        |          |            |        |            |      |
| 1/2 hp                            | 460/60/3         | ODP         | No                         | 1725         | 0.22 hp         |                |        |          |            |        |            |      |
| Heating                           |                  |             |                            |              |                 |                |        |          |            |        |            |      |
| Type                              | Steps            | Temperature |                            | Energy       |                 | Heater Voltage | MCA    | MOP      | SCCR       |        |            |      |
|                                   |                  | Winter DB   | Max Δ                      | Max LAT      | Input           |                |        |          |            | Output | Efficiency |      |
| Electric                          | SCR              | -1.6 F      | 73.1 F                     | 71.5 F       | 35.0 kW         | 31.4 A         | NA     | 460/60/3 | 40.8       | 45     | 5kA        |      |
| Outlet Sound Power By Octave Band |                  |             |                            |              |                 |                |        |          |            |        |            |      |
|                                   |                  | 125         | 250                        | 500          | 1000            | 2000           | 4000   | 8000     | LwA        | dBA    | Sones      |      |
| 62.5                              |                  | 65.4        | 65.6                       | 65.3         | 65.2            | 72.9           | 70.9   | 70.7     | 67.5       | 77.3   | 66.3       | 13.4 |

**OPTIONS AND ACCESSORIES**

Make Up Air  
 Air Flow Arrangement: Outdoor Air Only  
 Weatherhood: Aluminum Mesh, 16x20x2 - (4)  
 Damper: Inlet  
 Outdoor Air Intake Position: End  
 Discharge Position: Bottom  
 Coating: Galvanized  
 Insulation: Double Wall - Tempering On  
 Supply Fan Control: VFD  
 VFD Control: Constant Volume  
 Inlet Damper Module  
 Access Side: Right-Hand  
 Unit Weight: 944 lb  
 Control Center  
 Freeze Protection  
 Heat Inlet Air Sensor  
 Unit Controls: Microprocessor  
 Temperature Control: Discharge  
 Unit Warranty: 18 Months (std.)

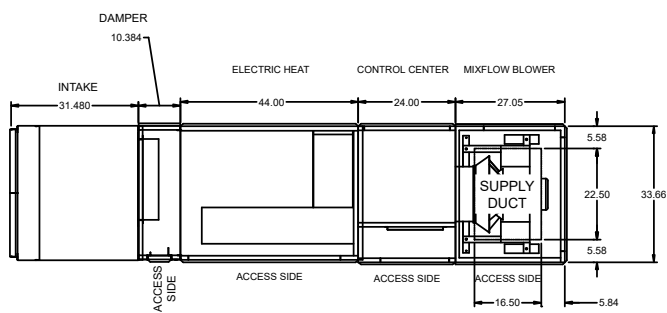

PLAN VIEW

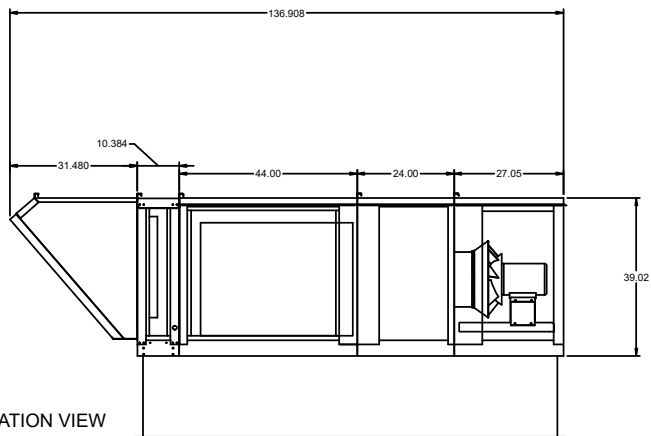

ELEVATION VIEW

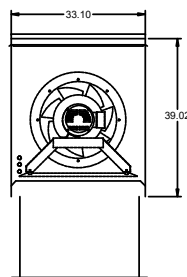

END VIEW

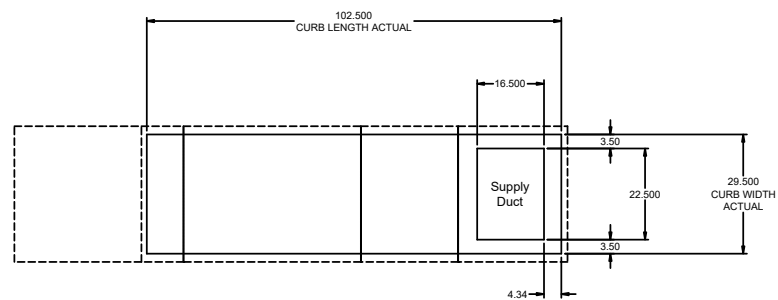

FOOTPRINT

NOTE: Roof Opening Requirements:

Minimum Roof Opening: The minimum roof opening size is the illustrated duct diameter plus 0.25 in. on all sides.  
 For example: If the duct size is 14 x 14 in. square, the minimum roof opening size is 14.5 x 14.5 in. square.

Maximum Roof Opening: There must be a minimum perimeter of 1.75 in. between the roof opening and the roof curb.  
 For example: If the roof curb is 75 x 30 in. square, the maximum roof opening is 71.5 x 26.5 in. inches square.

NOTE: The weatherhood and filter sections of the make-up air unit are not supported by the curb.  
 This is by design, in order to help alleviate water infiltration issues.

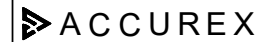
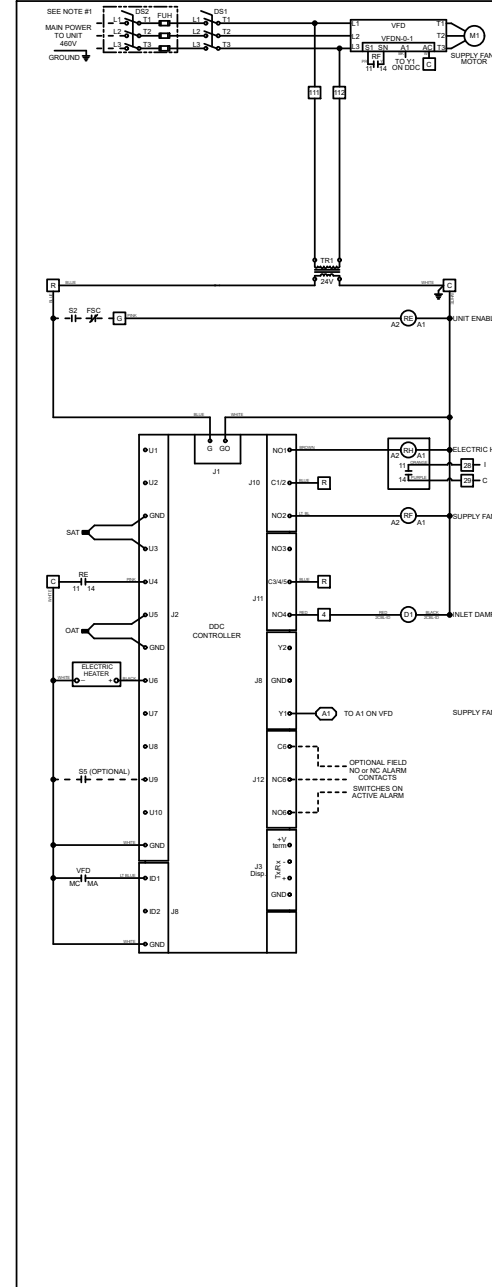

AS11N60BS010NX0NQ16

CAUTION  
 UNIT SHALL BE GROUNDED IN ACCORDANCE WITH N.E.C.  
 POWER MUST BE OFF WHILE SERVICING.

NOTES  
 USE COPPER CONDUCTORS ONLY  
 80° C FOR TERMINALS RATED LESS THAN 100 AMPS.  
 90° C FOR TERMINALS RATED 100 AMPS OR MORE.  
 FIELD CONTROL WIRING RESISTANCE SHOULD NOT EXCEED 0.75 OHM.  
 FIELD WIRE: - - - - -  
 FACTORY SUPPLIED AND WIRED: \_\_\_\_\_

NOTE #1  
 FIELD POWER TO UNIT WIRE TO ELECTRIC HEATER DISCONNECT D12 AND F1H LOCATED IN ELECTRIC HEATER  
 SEE ELECTRIC HEATER FOR SPECIFIC HEATER DIAGRAM

WIRE COLOR CODE  
 BK BLACK BL BLUE BR BROWN  
 GY GRAY LT BL LIGHT BLUE O ORANGE  
 PK PINK PR PURPLE R RED  
 W WHITE Y YELLOW

LEGEND  
 D1 INLET DAMPER  
 D11 MAIN DISCONNECT SWITCH  
 D12 ELECTRIC HEATER DISCONNECT SWITCH  
 LOCATED IN ELECTRIC HEATER  
 SUPPLIED BY HEATER MANUFACTURER  
 F1 FUSE  
 F1H FUSE - LOCATED IN ELECTRIC HEATER  
 SUPPLIED BY HEATER MANUFACTURER  
 M1 MOTOR  
 OAT OUTDOOR AIR TEMP  
 RE UNIT ENABLE RELAY  
 RF SUPPLY FAN RELAY  
 RH HEAT RELAY  
 S1 FAN SWITCH  
 S1 OCCUPIED/UNOCCUPIED SWITCH (OPTIONAL - REF. ICM)  
 CLOSED/OCCUPIED - OPEN/OCCUPIED  
 SAT SUPPLY AIR TEMP  
 T1 TRANSFORMER  
 VFD VARIABLE FREQUENCY DRIVE

Wiring Template: 016 DOC NUMBER: --- REV: ---

PROJECT 5/13/2025  
 MARK MUA1

ACCUREX NORTHERN IL  
 RAY SCHMIDT  
 RAY.SCHMIDT@ACCUREX.COM  
 (815)566-9619

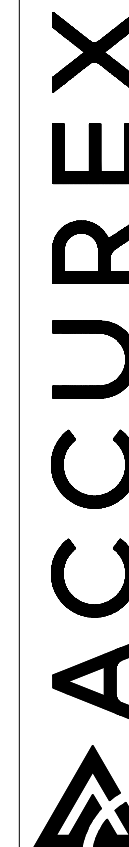

2/9/2026

**1-O-26**

**AN ORDINANCE**

**Amending Title 1, Chapter 17, “Contracts with the City”**

**WHEREAS**, the City of Evanston is a unit of local government organized and operating under federal and state laws; and

**WHEREAS**, on May 27, 2025, the City of Evanston adopted the Responsible Bidder Ordinance to ensure that only qualified contractors and subcontractors are awarded contracts on public works construction projects, and to ensure that workers on public works construction projects are paid appropriate wages and receive appropriate benefits in accordance with state and federal law; and

**WHEREAS**, from time to time the City of Evanston is able to secure external sources of funding, for instance from federal or state grants, that impose distinct sets of requirements for grant eligibility that do not always dovetail with the requirements of the current City Code; and

**WHEREAS**, the City of Evanston wishes to amend its ordinance on Contracts with the City to clarify how it intersects with external funding conditions;

**BE IT ORDAINED BY THE CITY COUNCIL OF THE CITY OF EVANSTON,  
COOK COUNTY, ILLINOIS:**

**SECTION 1:** Title 1, Chapter 17, “Contracts with the City,” is hereby amended as follows:

(A) All contracts with the City costing in excess of twenty-five thousand dollars (\$25,000.00) must be approved by the City Council. Contracts for the purchase of goods or services to be utilized in the conduct of the affairs of the City, shall be let by the City Manager or his/her designee, with the approval of the City Council, to a reliable, responsible and acceptable bidder, after advertising for the same, and bonds to be approved by the City Council may be taken for the faithful performance thereof.

(B) All contracts for the purchase of goods or services with entirely City funds shall be awarded to the lowest quote/bid price or lowest evaluated quote/bid price from a responsive and responsible Evanston business enterprise ("EBE") provided the EBE's quote/bid price does not surpass the lowest quote/bid price or lowest evaluated quote/bid price from a responsive and responsible nonlocal business by more than five percent (5%). All contracts let from requests for proposals (RFPs) and requests for qualifications (RFQs) with entirely City funds shall be awarded to the most qualified consultant that is an EBE, provided the EBE price/cost does not surpass the lowest price/cost or lowest evaluated price/cost from a nonlocal business by more than five percent (5%). This requirement is waived if the contract is partially or completely funded from a source other than funds belonging to the City of Evanston, such as federal, state, or other grants, and (ii) the other funding source mandates terms that are inconsistent with or supersede this Section (B).

1. An "EBE" shall mean an entity which is located in or has one or more offices located in the City for a minimum of one year and which performs a "commercially useful function."

a. An EBE performs a commercially useful function when it is responsible for execution of the work of the contract and is carrying out its responsibilities by actually performing, managing, and supervising the work involved. To perform a commercially useful function, the EBE must also be responsible, with respect to materials and supplies used on the contract, for negotiating price, determining quality and quantity, ordering the material, and installing (where applicable) and paying for the material itself. To determine whether an EBE is performing a commercially useful function, the City will evaluate the amount of work subcontracted, industry practices, whether the amount the firm is to be paid under the contract is commensurate with the work it is actually performing and the EBE credit claimed for its performance of the work and other relevant factors.

b. An EBE does not perform a commercially useful function if its role is limited to that of an extra participant in a transaction, contract, or project through which funds are passed in order to obtain the appearance of EBE participation. In determining whether an EBE is such an extra participant, the City will examine similar transactions, particularly those in which EBEs do not participate.

c. If an EBE does not perform or exercise responsibility for at least thirty (30) percent of the total cost of its contract with its own work force, or the EBE subcontracts a greater portion of the work of a contract than would be expected on the basis of normal industry practice for the type of

work involved, then it is not performing a commercially useful function.

d. When an EBE is presumed not to be performing a commercially useful function as provided in Subsection (B)1c of this Section, the EBE may present evidence to rebut this presumption. The City may determine that the firm is performing a commercially useful function given the type of work involved and normal industry practices.

2. In determining whether a business has been located in Evanston for one (1) year, the MWEBE Committee will consider the following:

a. Whether the vendor pays property and/or sales taxes in Evanston; and

b. Whether the business entity's address or the address given on the federal and/or state income tax return is within Evanston.

c. The date of issuance of an Evanston business license.

The City may waive the one-year requirement if the entity provides evidence of a substantial commitment to Evanston.

3. Businesses that maintain a distribution warehouse or which manufacture in Evanston will receive EBE credit of sixty (60) percent and one hundred (100) percent, respectively. Those that do not maintain a distribution warehouse or manufacturing operation but have an office in Evanston will be considered a broker and receive a five (5) percent credit.

4. Eligibility as an EBE will be periodically reviewed and may be revoked at any time if the entity no longer meets the above requirements.

INSERT: (C) Local Employment Program.

INSERT: (D) Minority, women, disadvantage, and Evanston business enterprise (M/W/D/EBE) goals.

(E) *Additional Requirements for Public Works Contracts.* All bidders for public works contracts must comply with the below specifications in bid submission and during the project for a successful bidder. The City Council may, by a majority vote of the members present, waive any of these requirements for an Evanston-owned business enterprise as defined in Subsection 1-17-1(D)(1) or a nearby business enterprise as defined in Subsection 1-17-1(E)(1).

1. *Definitions.* For the purposes of this Subsection, the following definitions apply:

|                                                   |                                                                                                                                                                                                                                                                                                                                                                                                                                                                                                  |
|---------------------------------------------------|--------------------------------------------------------------------------------------------------------------------------------------------------------------------------------------------------------------------------------------------------------------------------------------------------------------------------------------------------------------------------------------------------------------------------------------------------------------------------------------------------|
| <p><i>APPRENTICESHIP TRAINING PROGRAM.</i></p>    | <p>A program approved and registered by the United States Department of Labor's Office of Apprenticeship, or its successor organization, that has graduated at least five (5) apprentices in each other past five (5) years for each of the construction crafts the bidder will perform on the project. Evidence of graduation rates are not required for apprentice able crafts dedicated exclusively to the transportation of material and equipment to and from the public works project.</p> |
| <p><i>BIDDER.</i></p>                             | <p>A contractor that submits a bid in response to a City of Evanston request for proposal.</p>                                                                                                                                                                                                                                                                                                                                                                                                   |
| <p><i>COMMERCIALLY USEFUL FUNCTION.</i></p>       | <p>A business enterprise that is responsible for the execution of the work of the contract and is carrying out its responsibilities by actually performing, managing, and supervising the work involved.</p>                                                                                                                                                                                                                                                                                     |
| <p><i>NEARBY BUSINESS ENTERPRISE ("NBE").</i></p> | <p>A business enterprise located within five (5) miles of Evanston City limits for a minimum of one (1) year and performs a commercially useful function.</p>                                                                                                                                                                                                                                                                                                                                    |
| <p><i>PUBLIC WORKS CONTRACT.</i></p>              | <p>Any construction, alteration, demolition, or repair work done under contract on City-owned property.</p>                                                                                                                                                                                                                                                                                                                                                                                      |
| <p><i>RELIABLE, RESPONSIVE AND ACCEPTABLE</i></p> | <p>A bidder who submits a bid that conforms in all material respects to the requirements and criteria in the invitation for bids. This means the bid promises to perform in the precise manner requested by the government, and any minor irregularities in the bid shall not defeat responsiveness.</p>                                                                                                                                                                                         |

2. *Excessive Pass Through Prohibited.* Any bidder must directly perform at least twenty-five (25) percent of the services identified in the project solicitation. The named bidder submitting the bid must be the entity directly performing the services. Any affiliates and/or subsidiaries shall not contribute to the minimum performance percentage required.

3. *Apprenticeship Training Program Required.*

(a) Public Works contracts for over twenty-five thousand dollars (\$25,000.00) or greater shall only be let to: (i) a contractor with evidence of participation in an

apprenticeship training program applicable to the work to be performed on the project; or (ii) a contractor who has satisfied the experience requirements under subsection (d).

(b) All contracts submitted to the City Council must identify whether the contractor meets this requirement.

(c) Required evidence of participation in an apprenticeship program includes but is not limited to a copy of all applicable apprenticeship standards and apprenticeship agreement(s) for any apprentice(s) who will perform work on the public works project; and documentation from each applicable apprenticeship program certifying that it has graduated at least five (5) apprentices in each of the past five (5) years for each construction craft the bidder will perform on the project.

(d) Contractors may alternatively satisfy this requirement by certifying that all workers who will perform work on the public works project have relevant experience in lieu of participation in an apprenticeship program. Relevant experience may include: (i) performing at least one thousand eight hundred (1,800) hours of work in the trade the worker will perform on the public works project over the preceding two (2) years; (ii) completion of an apprenticeship program in the trade the worker will perform on the public works project; or (iii) obtaining a journeyman credential in the trade the worker will perform on the public works project. Required evidence to be eligible under this section includes but is not limited to W-2 records, journeyman credentials, apprenticeship completion cards, or certificates of graduation from apprenticeship programs. This requirement is waived if the contract is partially or completely funded from a source other than funds belonging to the City of Evanston, such as federal, state, or other grants, and (ii) the other funding source mandates terms that are inconsistent with or supersede this Section (E)(3)(d).

(e) Additional evidence of apprenticeship participation, graduation requirements, or previous experience may be requested by the City of Evanston in its discretion.

4. *Occupational Safety and Health Administration Safety Cards Required.* Prior to beginning work for the City, the bidder shall certify that all employees for the contractor that will be on the work site shall have completed a ten-hour or greater OSHA safety program. The contractor must submit copies of the employees' OSHA cards to the City prior to the project commencing.

5. *Nearby Business Enterprises.* In the absence of an Evanston business enterprise as required by City Code 1-17-1(B), the City shall award the contract for the public works

contract to the lowest bid price or lowest evaluated quote/bid price from a responsive or responsible NBE, provided that the NBE's bid price does not surpass the lowest bid price or lowest evaluated bid price from a responsible and responsible non NBE or EBE business by more than three (3) percent. This requirement is waived if the contract is partially or completely funded from a source other than funds belonging to the City of Evanston, such as federal, state, or other grants, and (ii) the other funding source mandates terms that are inconsistent with or supersede this Section (E)(5).

a. An NBE shall perform a commercially useful function.

i. To determine whether an NBE is performing a commercially useful function, the City will evaluate the amount of work subcontracted, industry practices, whether the amount the firm is to be paid under the contract is commensurate with the work it is actually performing and the NBE credit claimed for its performance of the work and other relevant factors.

ii. An NBE does not perform a commercially useful function if its role is limited to that of an extra participant in a transaction, contract, or project through which funds are passed in order to obtain the appearance of NBE participation. In determining whether an NBE is such an extra participant, the City will examine similar transactions, particularly those in which NBEs do not participate.

iii. If an NBE does not perform or exercise responsibility for at least thirty (30) percent of the total cost of its contract with its own work force, or the NBE subcontracts a greater portion of the work of a contract than would be expected on the basis of normal industry practice for the type of work involved, then it is not performing a commercially useful function.

iv. When an NBE is presumed not to be performing a commercially useful function as provided in Subsection (B)1c of this Section, the EBE may present evidence to rebut this presumption. The City may determine that the firm is performing a commercially useful function given the type of work involved and normal industry practices.

b. In determining whether a business has been located in Evanston or within five (5) miles of Evanston City limits for one (1) year, the MWEBE Committee will consider the following:

i. Whether the vendor pays property and/or sales taxes in Evanston, or, in the case of a NBE, in a community that is within five (5) miles of City limits;  
~~and~~

- ii. Whether the business entity's address or the address given on the federal and/or state income tax return is within Evanston or, in the case of a NBE, in a community that is within five (5) miles of City limits; and
  - iii. The date of issuance of an Evanston business license or, in the case of a NBE, the date of issuance of a business license by a community located within five (5) miles of City limits.
  - iv. The City may waive the one-year requirement if the entity provides evidence of a substantial commitment to Evanston.
- c. Businesses that maintain a distribution warehouse or which manufacture in Evanston will receive EBE credit of sixty (60) percent and one hundred (100) percent, respectively. Those that do not maintain a distribution warehouse or manufacturing operation but have an office in Evanston will be considered a broker and receive a five (5) percent credit.
- d. Eligibility as an NBE will be periodically reviewed and may be revoked at any time if the entity no longer meets the above requirements.

6. *Certifications Required at Time of Bid Submittal.* All bidders, including any subcontractors included in the bid, as applicable, shall be compliant and shall submit certification of compliance with the following at the time of the bid submittal:

- a. The Prevailing Wage Act, 820 ILCS 130/1 *et seq.*
  - i. Compliance with the Prevailing Wage Act is required for the previous five (5) years and certification that the contractor has not been found in violation of the Prevailing Wage Act by the Illinois Department of Labor; and
  - ii. A contractor who has been found by the Illinois Department of Labor to be in violation of the Prevailing Wage Act twice in a five-year period shall be barred from bidding for a Public Works contract for four (4) years from the date of the most recent finding from the Illinois Department of Labor.
- b. The Substance Abuse Prevention on Public Works Project Act, 820 ILCS 265/1 *et seq.*
  - i. Compliance with the Substance Abuse Prevention on Public Works Act must include a copy of its written program for the prevention of substance abuse pursuant to the Act.

c. The Workers' Compensation Act, 820 ILCS 305/1 et seq.;

i. A copy of the applicable workers' compensation policy must be submitted to the City along with documentation of the Illinois Department of Labor registration. The bidder shall additionally certify that all employees are properly classified under the workers' compensation policy.

d. The Unemployment Insurance Act, 820 ILCS 405/100, et seq.;

i. A copy of the applicable Illinois Department of Employment Security current registration.

e. A copy of the Illinois Secretary of State's Department of Business Services online records evidencing that the bidder has a current corporate annual report on file. If the bidder is an individual, sole proprietor, or partnership, this subsection shall not apply;

f. A copy of the current registration with the Illinois Department of Revenue, if the bidder has employees;

g. A disclosure of any Federal, State or local tax liens or tax delinquencies against the bidder or any officers of the bidder in the last five (5) years;

~~h. Reserved;~~

~~h.~~ h. Compliance with the Federal Davis-Bacon Act and Related Acts, if applicable;

~~j.~~ i. Compliance with the Employee Classification Act 820 ILCS 185/1, et seq.;

i. All contractors and subcontractors shall submit certified payrolls as specified in Illinois Public Act 94-0515.

~~k.~~ j. All applicable professional or trade licensure, including documentation of said licenses, certification that all licenses are current, and disclosure of any suspension or revocation of such license held by the company, or of any director, officer or manager of the company;

~~k.~~ k. Certification of compliance with 720 ILCS 5/33E-11 and that the bidder is not barred from contracting with any unit of State or local government as a result of a violation of 720 ILCS 5/33E-3, 4;

**m. l.** Certification that all individuals who perform work on behalf of the contractor are properly classified as either (i) an employee, or (ii) an independent contractor under all applicable state and federal laws and local ordinances; and

**n. m.** Disclosure of any determinations by a court, State or Federal agency of violations of any federal, state or local laws, including but not limited to OSHA, contracting or antitrust laws, tax or licensing laws, environmental laws or the Federal Davis-Bacon and Related Acts.

Any bidder who fails to adhere to this Subsection shall be deemed disqualified from the bid process. If a bidder or contractor has a material change to the information provided to the City of Evanston, the bidder or contractor must notify the City within fourteen (14) days of this material change in writing. Failure to self-report a material change may result in disqualification from the bid.

*7. Subcontractors.* A bidder shall submit documentation including the name and address of each subcontractor from whom the bidder has accepted a bid and/or intends to hire on any part of the project. Further, each such subcontractor shall be required to adhere to the requirements set forth herein as though it were bidding directly to the City of Evanston. Each contractor shall submit all subcontractor information and supporting documentation to the City of Evanston prior to the subcontractor commencing work on the project. It shall be the responsibility of the bidder to ensure its subcontractors comply with all of the requirements of this Code, including the timely and complete submittals of all required documentation and full compliance with all obligations set forth in this Section.

*8. Certification for 12-Month Period.* In anticipation of bidding on a project, a contractor may submit the certifications identified in the preceding section to the City's Purchasing Manager or their designee. The Purchasing Manager or their designee shall review the certifications for completeness. Upon review, if the certifications are complete, the Purchasing Manager or their designee shall advise the contractor of same via an email address designated by the contractor. If the certifications are incomplete, the contractor shall be also notified via email and given fourteen (14) days to complete the submission. Once the certifications are completed, the contractor shall be notified of a "Certification for 12-Month Period" and shall not be required to resubmit these certifications for a period of twelve (12) months following the notification. Any material changes to these certifications shall be reported in writing to the City's Purchasing Manager or designee. In the event that these documents are still required to be submitted by a State or Federal agency that is contributing funding to a project, this provision shall not apply.

*9. Projects of Similar Size and Scope.* In projects in the amount of twenty-five

thousand dollars (\$25,000.00) or greater, bidders shall identify and submit documentation with their bid of relevant experience on projects of similar size and scope in the past five (5) years and submit references for same. Projects of similar size and scope shall be as further defined and outlined in the request for proposal ("RFP"). The bidder shall also identify any civil judgments, mediation or arbitration awards against it for default, breach, or damages due to delay or work inadequately performed. Information submitted pursuant to this section shall be considered in determining responsible bidders for the project at issue.

10. *Statement of Past Performance.* Bidders shall submit with their bid a record of all work performed for public bodies completed in the prior three (3) years. Such statements shall include the name of the public body, the type of work performed, the original contract price, the final contract price, the names of all subcontractors used and if liquidated damages were assessed.

11. *Public Records.* All information submitted by a successful bidder pursuant to this Section ~~are~~ is subject to review pursuant to the Illinois Freedom of Information Act (5 ILCS 140/1 *et seq.*).

INSERT (F) Contractor Debarment, Suspension, and Prohibited Contracts

**SECTION 2:** All ordinances or parts of ordinances in conflict herewith are hereby repealed.

**SECTION 3:** If any provision of this Ordinance or application thereof to any person or circumstance is held unconstitutional or otherwise invalid, such invalidity shall not affect other provisions or applications of this Ordinance that can be given effect without the invalid application or provision, and each invalid application of this Ordinance is severable.

**SECTION 4:** This Ordinance shall be in full force and effect beginning upon passage.

**SECTION 5:** The findings and recitals contained herein are declared to be prima facie evidence of the law of the City and shall be received in evidence as provided by the Illinois Compiled Statutes and the courts of the State of Illinois.

Introduced: \_\_\_\_\_ February 9, 2026

Approved:

Adopted: \_\_\_\_\_ February 9, 2026

\_\_\_\_\_ February 10, 2026

  
boxSIGN 4LR35Q59-46V7LZRJ

\_\_\_\_\_  
Daniel Biss, Mayor

Attest:

Approved as to form:

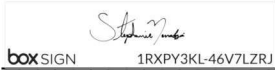
  
boxSIGN 1RXPY3KL-46V7LZRJ

\_\_\_\_\_  
Stephanie Mendoza, City Clerk

  
boxSIGN 1VWVZ88Z-46V7LZRJ

\_\_\_\_\_  
Alexandra B. Ruggie, Corporation Counsel

SECTION 1: Title 1, Chapter 17, "Contracts with the City," is hereby amended as follows:

(C) Local Employment Program.

(D) Minority, women, disadvantage, and Evanston business enterprise (M/W/D/EBE) goals.

(F) Contractor Debarment, Suspension, and Prohibited Contracts.

(C) Local Employment Program.

1. *Definitions.* For the purposes of this Subsection (C), the employment program, the following terms shall be defined as follows:

|                                 |                                                                                                                                                                                                                                                                                                                                                                                                                         |
|---------------------------------|-------------------------------------------------------------------------------------------------------------------------------------------------------------------------------------------------------------------------------------------------------------------------------------------------------------------------------------------------------------------------------------------------------------------------|
| <i>CONTRACT.</i>                | The written agreement to provide services established between the City and a contractor, including, but not limited to, a redevelopment agreement between the City and any contractor or party.                                                                                                                                                                                                                         |
| <i>CONTRACTOR.</i>              | An individual, partnership, corporation, joint venture or other legal entity entering into a contract, or a subcontract of whatever tier, for a public works project.                                                                                                                                                                                                                                                   |
| <i>DESK REVIEW.</i>             | A method of monitoring compliance with the local employment program in which the Business and Workforce Development                                                                                                                                                                                                                                                                                                     |
|                                 | Coordinator contacts a contractor or subcontractor to gather relevant information or request relevant documentation.                                                                                                                                                                                                                                                                                                    |
| <i>EMERGENCY WORK.</i>          | Work necessitated by an imminent threat to the property of the city or the health, safety, or welfare of its citizens.                                                                                                                                                                                                                                                                                                  |
| <i>GENERAL CONTRACTOR.</i>      | An entity that enters into a contract directly with the city. The general contractor may also be known as the prime contractor.                                                                                                                                                                                                                                                                                         |
| <i>LOCAL RESIDENT DATABASE.</i> | A database maintained by the City's Business and Workforce Development Coordinator containing the names of local residents who have expressed interest in employment on City public works projects.                                                                                                                                                                                                                     |
| <i>NEW HIRE.</i>                | Any employee of a contractor who is not listed on the contractor's last quarterly tax statement and was hired prior to or during the commencement of work on a public works project contract subject to the requirements of the local employment program.                                                                                                                                                               |
| <i>ON SITE MONITORING.</i>      | The Business and Workforce Development Coordinator's act of visiting the site of a public works project to ensure compliance with the requirements of the local employment program.                                                                                                                                                                                                                                     |
| <i>PUBLIC WORKS PROJECT.</i>    | Any construction, alteration, demolition, or repair work done under contract and paid for in whole or in part from City funds.                                                                                                                                                                                                                                                                                          |
| <i>RESIDENT.</i>                | Any person whose domicile is in the City. The domicile is an individual's one and only true, fixed and permanent home and principal establishment. In order to qualify as a resident for purposes of the local employment program, an individual must have established domicile within the City at least thirty (30) days prior to commencing work on any public works project subject to the local employment program. |
| <i>SUBCONTRACT.</i>             | A contract that exists between the general contractor and a subcontractor or between subcontractors of any tier.                                                                                                                                                                                                                                                                                                        |
| <i>SUBCONTRACTOR.</i>           | An entity that enters into a contract with the general contractor or another subcontractor.                                                                                                                                                                                                                                                                                                                             |
| <i>TIER.</i>                    | The level of relationship to the prime contractor of a subcontractor who enters into a contract under a prime contractor or another subcontractor to perform a portion of the work on a project.                                                                                                                                                                                                                        |

2. *Work hours and new hire requirements.*

- a. Unless prohibited by federal, state, or local law, all contractors entering into contracts with the City for public works projects valued at two hundred fifty thousand dollars (\$250,000.00) shall ensure that:
  - 1) Fifteen percent (15%) of the total work hours are performed at the construction site by City of Evanston residents, as laborers and/or trade persons; and
  - 2) A minimum of one (1) Evanston resident is hired.

- b. The effectiveness of the local employment program regarding the minimum percentage of work hours and residents hired will be evaluated by city staff after two (2) years of implementation.
  - c. These requirements shall bind the contractor both with respect to persons working directly for the contractor and to subcontractors, regardless of tier or phase of the project, hired to perform any portion of the contracted work. The contractor shall ensure that subcontractors comply with the requirements of the local employment program. It shall be the responsibility and obligation of the contractor that all contracts are in overall compliance with this Subsection (C) and all the requirements listed herein.
  - d. Requirements of the local employment program are satisfied if the contractor already employs Evanston residents sufficient to meet fifteen percent (15%) of the project's total work hours. Some or all of these requirements may be waived if a waiver is obtained from the City pursuant to Subsection (C)5. of this Section.
3. *Contracts, bid documents, subcontracts.* Where appropriate and consistent with law, contracts and bid documents shall incorporate the local employment program by reference and shall provide that the failure of any contractor or subcontractor to comply with any of its requirements shall be deemed a material breach of the contract or subcontract entitling the City to all the remedies and damages available for material breach of a contract. All subcontracts shall expressly acknowledge the City's status as a third party beneficiary to the subcontract and further expressly acknowledge that the City, as a third party beneficiary, shall have the right to enforce the provisions of the local employment program. Contracts and bid documents shall require bidders, contractors and subcontractors to maintain records necessary for monitoring their compliance with the local employment program.
4. *Automatic review.* This Subsection (C) shall be reviewed to address any deficiencies on a bi-annual basis by the Minority, Women and Evanston Business Enterprise Development Committee.
5. *Waiver.*
- a. The contractor may request that the Business and Workforce Development Coordinator waive all or a portion of the requirements imposed under the local employment program. Such requests must be in writing and must be received by the Business and Workforce Development Coordinator prior to the award of any public works project contract. In order to apply for a waiver, the contractor must submit:
    - 1) Documentation to the Business and Workforce Development Coordinator demonstrating that:
      - a) The contractor utilized the local resident database to attempt to satisfy the local employment program hiring requirement.

- b) The contractor notified residents of the employment opportunities available for the project. Such notification must have appeared in the employment section of a newspaper of local general circulation. Additionally, the Illinois department of employment security's office located in Evanston, Illinois, must have been notified of the employment opportunities. All notices must have stated that all qualified applicants would receive consideration without regard to race, color, religion, sex or national origin.
    - c) The contractor, for a contract utilizing union labor, contacted in writing Chicagoland labor unions to request a resident for employment on the project.
  - 2) Any additional documents requested by the Business and Workforce Development Coordinator in order to evaluate the waiver request.
- 6. *Business and Workforce Development Coordinator.*
  - a. The Business and Workforce Development Coordinator shall determine, based on the required documentation and conditions cited by the contractor that make compliance unfeasible, whether to grant the waiver prior to the award of the contract. Examples of such conditions include, but are not limited to:
    - 1) Intermittent service by one (1) trade throughout the life of the project.
    - 2) Nonavailability of resident(s) necessary to fulfill craft position(s) required for the project.
  - b. If circumstances arise subsequent to the issuance of the contract, the results of which the contractor believes will prevent satisfying the local employment program requirements, the contractor will immediately notify the Business and Workforce Development Coordinator by requesting in writing a waiver of the percentage that cannot be met. The Business and Workforce Development Coordinator or his or her designee shall meet with the applicant as necessary and issue a decision within five (5) business days, including a determination as to any retroactive liability for failure to achieve the goals for work undertaken prior to the application for such a waiver.
- 7. *Local resident selection.* It is the contractor's responsibility to meet the requirement of the local employment program. In order to satisfy the work hours and/or new hire requirements of the local employment program, contractors working under a collective bargaining agreement shall contact the appropriate local union hall to request a resident. If a resident is not available for dispatch by that union hall, the contractor shall contact the Business and Workforce Development Coordinator or his or her designee to request an available Evanston resident. The Business and Workforce Development Coordinator or his or her designee will thereafter provide the name of a resident matching the qualifications defined by the contractor to the local union

hall and that resident will be dispatched to the contractor within three (3) business days in accordance with the lawful hiring hall rules of the respective union. Failure of the Business and Workforce Development Coordinator to provide an individual shall not relieve the contractor from their responsibility to comply with the local employment program.

In order to satisfy the work hours and/or new hire requirement of the local employment program, contractors working in the absence of a collective bargaining agreement shall contact the Business and Workforce Development Coordinator or his or her designee to request an available Evanston resident from the local resident database. The Business and Workforce Development Coordinator or his or her designee will provide the name of a resident matching the qualifications identified by the contractor within three (3) business days.

8. *Reporting requirements.* The contractor shall submit reports as required by the City in order to comply with the local employment program. These reports may include weekly certified payroll records for all crafts within five (5) working days of the end of each payroll period. Additionally, the City may require a weekly or monthly summary of the information that would be obtainable from the certified payroll regarding local hire by craft. These reports, if required, must show the person-hours on a laborer and/or trade person basis and, in the case of certified payroll records, identify the address, new hires, and trade and status journeyman or apprentice of all employees on the project. All reports must have an original signature and be signed by an authorized officer of the company under penalty of perjury. The City will make a copy of all required forms available to contractors.

Nothing in the local employment program is intended to eliminate the requirement of a contractor to maintain certified payrolls or of the subcontractors to provide certified payrolls to the contractor, or for any contractor to provide certified payrolls to any party that requests them, as required under Illinois state law.

9. *Monitoring.* The Business and Workforce Development Coordinator or his or her designee will monitor compliance with the requirements of the local employment program by means including, but not limited to, desk reviews or on site monitoring. Audits of compliance may require the review of documents such as certified payrolls, canceled checks, or quarterly wage and withholding reports. Full scale investigations of noncompliance or violations will be on an as needed basis as determined by the Business and Workforce Development Coordinator.

A contractor that fails to provide requested documents or misrepresents material facts in such documents shall be deemed to be noncompliant with the local employment program.

10. *Post-award meeting.* At its discretion, the Business and Workforce Development Coordinator or his or her designee may require the contractor to attend a post-award meeting to familiarize the contractor with the local employment program requirements and to identify the individual by position

and name if available. If requested by the contractor post-award, or at any time during the project, the City shall hold such a meeting within ten (10) business days.

11. *Penalty.* If the contractor or subcontractor should fail to meet the total percentage of resident project hours for any reason, without having received a waiver as outlined in Subsection (C)5. above, the City may impose a fine up to one percent (1.0%) of the approved project price in total. Contractors or subcontractors that are out of compliance due to a resident termination or resignation, shall immediately notify the Business and Workforce Development Coordinator of this occurrence within two (2) business days. Subsequently, the contractor or subcontractor shall have five (5) additional business days to replace a terminated or resigned worker with another resident. If the contractor or subcontractor fails to make the replacement or to notify the Business and Workforce Development Coordinator of this occurrence, the offending party will also be subject to a penalty up to one percent (1.0%) of the approved project price. If the noncompliant contractor makes a good faith effort to replace the resident, the fine may be waived.

At the sole discretion of the City, a contractor or subcontractor that has violated the terms of the local employment program within a three-year period may be determined a non-responsible bidder and excluded from bidding on future projects for a period of not less than one (1) year.

At the sole discretion of the City, an employee that has been hired through the LEP may be removed from the program for a period of not less than one (1) year for failing to adhere to program guidelines or due to termination by the contractor for cause. Such termination process will be reviewed by the Business and Workforce Development Coordinator.

12. *Workforce reserve account.* The City shall establish a reserve account for the deposit of all penalty funds within the general fund. This account may be utilized for the support of the LEP and other workforce development programs as follows:
  - The MWEBE Committee shall receive a report on the balance of penalty funds as of the end of the fiscal year no later than March 31 after the close of that year.
  - The MWEBE Committee shall recommend utilization of these funds for placement in the next year's proposed budget in accordance with current LEP and workforce development program goals.
  - Both program goals and recommended expenditure of funds will be subject to approval by the City Council.

(D) *Minority, women, disadvantage, and Evanston business enterprise (M/W/D/EBE) goals.*

1. *Definitions.* For the purposes of this Subsection (D), Minority, Women, Disadvantage, and Evanston Business Enterprise (M/W/D/EBE) Goals, the following terms shall be defined as follows:

|                                                       |                                                                                                                                                                                                                                                                                                                                                                                                                                                                                                                                                          |
|-------------------------------------------------------|----------------------------------------------------------------------------------------------------------------------------------------------------------------------------------------------------------------------------------------------------------------------------------------------------------------------------------------------------------------------------------------------------------------------------------------------------------------------------------------------------------------------------------------------------------|
| <i>DISADVANTAGE-OWNED BUSINESS ENTERPRISE or DBE.</i> | A firm must be at fifty-one percent (51%) owned by one (1) or more disadvantaged individual (socially and economically) or, in the case of a publicly-held corporation, fifty-one percent (51%) of the stock of which is owned by one (1) or more disadvantaged individual (socially and economically) whose management and daily business operations are controlled by one (1) or disadvantaged individual (socially and economically). The City Manager or his or her designee shall determine which DBE certifications shall be accepted by the City. |
| <i>EVANSTON-OWNED BUSINESS ENTERPRISE or EBE.</i>     | An entity which is located in or has one (1) or more offices located in the City for a minimum of one (1) year and which performs a "commercially useful function." The business must be certified by the City in accordance with the provisions of Section 1-17-1(B).                                                                                                                                                                                                                                                                                   |
| <i>MINORITY-OWNED BUSINESS ENTERPRISE or MBE.</i>     | A business which is at least fifty-one percent (51%) owned by one (1) or more members of one (1) or more minority groups, or, in the case of a publicly-held corporation, at least fifty-one percent (51%) of the stock of which is owned by one (1) or more members of one (1) or more minority groups, whose management and daily operations are controlled by one (1) or more members of one (1) or more minority groups. The City Manager or his or her designee shall determine which MBE certifications shall be accepted by the City.             |
| <i>M/W/D/EBE GOALS.</i>                               | The City of Evanston establishes the goal of awarding not less than twenty-five percent (25%) of its contract awards to MBE, WBE, DBE and EBE businesses. The City of Evanston establishes the goal of awarding not less than three percent (3%) utilization of EBEs in its contract awards. The provisions of this Section shall be implemented by the City Manager or his or her designee. The provisions of this Section do not guarantee contract participation.                                                                                     |
| <i>WOMEN-OWNED BUSINESS ENTERPRISE or WBE.</i>        | A business which is at least fifty-one percent (51%) owned by one (1) or more women, or, in the case of a publicly-held corporation, fifty-one percent (51%) of the stock of which is owned by one (1) or more women, whose management and daily business operations are controlled by one (1) or more women. The City Manager or his or her designee shall determine which WBE certifications shall be accepted by the City.                                                                                                                            |

2. A minority-owned business enterprise ("MBE"), women-owned business enterprise ("WBE"), or disadvantage-business enterprise ("DBE") (collectively, "M/W/D/BE") must perform a "commercially useful function."
  - a. A M/W/D/BE performs a commercially useful function when it is responsible for execution of the work of the contract and is carrying out its responsibilities by actually performing, managing, and supervising the work involved. To perform a commercially useful function, the M/W/D/BE

must also be responsible, with respect to materials and supplies used on the contract, for negotiating price, determining quality and quantity, ordering the material, and installing (where applicable) and paying for the material itself. To determine whether an M/W/D/BE is performing a commercially useful function, the City will evaluate the amount of work subcontracted, industry practices, whether the amount the firm is to be paid under the contract is commensurate with the work it is actually performing and the M/W/D/BE credit claimed for its performance of the work and other relevant factors.

- b. A M/W/D/BE does not perform a commercially useful function if its role is limited to that of an extra participant in a transaction, contract, or project through which funds are passed in order to obtain the appearance of M/W/D/BE participation. In determining whether a M/W/D/BE is such an extra participant, the City will examine similar transactions, particularly those in which M/W/D/BE's do not participate.
  - c. If a M/W/D/BE does not perform or exercise responsibility for at least thirty percent (30%) of the total cost of its contract with its own work force, or the M/W/D/BE subcontracts a greater portion of the work of a contract than would be expected on the basis of normal industry practice for the type of work involved, then it is not performing a commercially useful function.
  - d. When an M/W/D/BE is presumed not to be performing a commercially useful function as provided in Subsection (D)(2)(c) of this Section, the M/W/D/BE may present evidence to rebut this presumption. The City may determine that the firm is performing a commercially useful function given the type of work involved and normal industry practices.
3. Businesses that maintain a distribution warehouse or manufacturing operation will receive M/W/D/BE credit of sixty percent (60%). Those that do not maintain a distribution warehouse or manufacturing operation will be considered a broker and receive a five (5) percent credit.
  4. Eligibility as a M/W/D/BE will be periodically reviewed and may be revoked at any time if the entity no longer meets the above requirements.

(E) (F) Contractor Debarment, Suspension, and Prohibited Contracts.

1. *Definitions.* For the purposes of this Subsection, the following definitions apply:

|                      |                                                                                                                                                                                                                                                                                                                                                                                                                           |
|----------------------|---------------------------------------------------------------------------------------------------------------------------------------------------------------------------------------------------------------------------------------------------------------------------------------------------------------------------------------------------------------------------------------------------------------------------|
| <i>CITY MANAGER.</i> | The City of Evanston City Manager or his/her designee.                                                                                                                                                                                                                                                                                                                                                                    |
| <i>CONTRACTOR.</i>   | A person, partnership, corporation, or other entity that has contracted with, or is seeking to contract with, the City to construct a public improvement, to provide goods to, or perform services for or on behalf of the City. A contractor includes a contractor, subcontractor, vendor, or any person or entity who or which owns an interest of ten percent (10%) or more in a contractor, subcontractor, or vendor. |
| <i>DEBARMENT.</i>    | An action taken by the City which results in a contractor being prohibited from bidding or proposing on, being awarded or performing work on a contract with the City. A contractor who has been determined by the City to be subject to such a prohibition is debarred.                                                                                                                                                  |

2. *Effect of Debarment or Suspension.* A debarred or suspended contractor is prohibited from bidding or proposing or being awarded or performing work on a contract with the City during the period of debarment or suspension.
3. *Debarment or Suspension.* The City Manager is authorized to debar or suspend a contractor for just cause. The period of debarment or suspension will be determined by the City Manager in consultation with the Corporation Counsel, on a case by case basis. Debarment or suspension may be lifted for good cause shown. Reasons for debarment or suspension include, but are not limited to, the following:
- a. Commission of fraud or a criminal offense as an incident to obtaining or attempting to obtain a public or private contract or subcontract or in the performance of such a contract or subcontract;
  - b. Conviction or indictment under a State or Federal statute of embezzlement, theft, forgery, bribery, falsification or destruction of records, receiving stolen property, or any other offense indicating a lack of business integrity or business honesty which affects responsibility as a vendor or contractor;
  - c. Conviction or indictment under a State or Federal antitrust statute;
  - d. A finding by a State or Federal agency with statutory authority to adjudicate civil rights violations, or by a judge or jury in a State or Federal

- court of competent jurisdiction, that the vendor or contractor has violated State or Federal civil rights statutes in its hiring or business practices;
- e. Failure or default without good cause to perform in accordance with the terms of any contract and the associated supporting documents or unsatisfactory performance of any contract and the associated supporting documents with the City;
  - f. Disqualification or rejection of a bid by the vendor on three (3) or more occasions within a three (3) year period;
  - g. Commission of an act or omission indicating a lack of business integrity or business honesty;
  - h. Debarment, disqualification or suspension by another government entity for any reason; or
  - i. Any Federal or State funding that, by law, rule, or regulation, precludes the City from paying a contractor from those funding.
4. *Procedure.* Before a contractor is debarred or suspended, written notice of debarment or suspension must be provided to that contractor. Such notice must apprise the contractor of the reasons for the debarment or suspension and must inform the contractor of the right to be heard before the City Manager. The City Manager must grant a reasonable opportunity for the debarred or suspended contractor to be heard on the issue of said disbarment or suspension, if the contractor submits a request in writing within seven (7) calendar days of the mailing of the written notice. The City Manager will make a final determination after consulting with Corporation Counsel.
5. *Assignment of Contracts.* No contract will be assigned or sublet by the successful bidder without the consent of the City Manager.
6. *Prohibited Bidders and Contractors.*
- a. Unless otherwise provided, no contractor will bid or enter into a contract or subcontract under this Subsection if the business or any officer, director, partner, or other managerial agent of the business has been convicted of a felony under the Sarbanes-Oxley Act of 2002 or a Class 3 or Class 2 felony under the Illinois Securities Law of 1953 for a period of five (5) years from the date of conviction.
  - b. Every bid submitted to and contract executed by the City and every subcontractor will contain a certification by the bidder, contractor, or subcontractor, respectively, that the bidder, contractor, or subcontractor is not barred from being awarded a contract or subcontract under this Section and acknowledges that the City Manager will declare the related contract void if any of the certificates completed pursuant to this Subsection (b) are false.
7. *Debt Delinquency.*

- a. No person will submit a bid for or enter into a contract or subcontract under this Section if that person knows or should know that they or any affiliate is delinquent in the payment of any debt to the City, unless the person or affiliate has entered into a deferred payment plan to pay off the debt.
  - b. Every bid submitted to and contract executed by the City and every subcontract will contain a certification by the bidder, contractor, or subcontractor, respectively, that the contractor or the subcontractor and its affiliate is not barred from being awarded a contract or subcontract under this Section and acknowledges that the City Manager may declare the related contract void if any of the certifications completed pursuant to this Subsection (b) are false.
8. *Voidable Contracts.*
- a. If any contract or amendment is entered into or purchase or expenditure of funds is made at any time in violation of this Subsection or any other law, the contract or amendment may be declared void by the City Manager or may be ratified and affirmed, provided the City Manager determines that ratification is in the best interests of the City. If the contract is ratified and affirmed, it will be without prejudice to the City's rights to any appropriate damages.
  - b. If, during the term of a contract, the City Manager determines that the contractor is delinquent in the payment of debt as set forth in Subsection 1-17-1(E)(7), the City Manager, or his/her designee, may declare the contract void if he/she determines that voiding the contract is in the best interests of the City.
  - c. If, during the term of a contract, the City Manager determines that the contractor is in violation of Subsection 1-17-1(E)(6), the City Manager will declare the contract void.
  - d. If, during the term of a contract, the contracting agency learns from an annual certification or otherwise determines that the contractor no longer qualifies to enter into City contracts under this Section, the City Manager may declare the contract void if he/she determines that voiding the contract is in the best interests of the City.

## Cook County Prevailing Wage Rates posted on 3/2/2026

| Trade Title                | Rg  | Type | C | Base  | Foreman | Overtime |     |     |     |       | Pension | Vac  | Trng | Other Ins | Add OT 1.5x owed | Add OT 2.0x owed |
|----------------------------|-----|------|---|-------|---------|----------|-----|-----|-----|-------|---------|------|------|-----------|------------------|------------------|
|                            |     |      |   |       |         | M-F      | Sa  | Su  | Hol | H/W   |         |      |      |           |                  |                  |
| ASBESTOS ABT-GEN           | All | ALL  |   | 51.40 | 52.40   | 1.5      | 1.5 | 2.0 | 2.0 | 18.32 | 17.71   | 0.00 | 0.91 | 0.00      | 0.00             | 0.00             |
| ASBESTOS ABT-MEC           | All | BLD  |   | 42.02 | 45.38   | 1.5      | 1.5 | 2.0 | 2.0 | 16.44 | 16.64   | 0.00 | 0.92 |           | 3.37             | 6.73             |
| BOILERMAKER                | All | BLD  |   | 58.91 | 64.21   | 2.0      | 2.0 | 2.0 | 2.0 | 7.07  | 27.02   | 0.00 | 3.69 | 2.31      | 0.00             | 39.30            |
| BRICK MASON                | All | BLD  |   | 53.06 | 58.37   | 1.5      | 1.5 | 2.0 | 2.0 | 12.95 | 26.26   | 0.00 | 1.57 | 0.00      | 4.23             | 8.45             |
| CARPENTER                  | All | ALL  |   | 56.71 | 58.71   | 1.5      | 1.5 | 2.0 | 2.0 | 13.64 | 27.26   | 2.61 | 1.04 |           | 0.00             | 0.00             |
| CEMENT MASON               | All | ALL  |   | 53.10 | 55.10   | 2.0      | 1.5 | 2.0 | 2.0 | 18.43 | 24.00   | 0.00 | 1.25 |           | 2.50             | 5.00             |
| CERAMIC TILE FINISHER      | All | BLD  |   | 49.09 | 49.09   | 1.5      | 1.5 | 2.0 | 2.0 | 13.25 | 17.61   | 0.00 | 1.37 | 0.00      | 5.57             | 11.14            |
| CERAMIC TILE LAYER         | All | BLD  |   | 57.04 | 62.04   | 1.5      | 1.5 | 2.0 | 2.0 | 13.25 | 21.60   | 0.00 | 1.50 | 0.00      | 7.63             | 15.26            |
| COMMUNICATION ELECTRICIAN  | All | BLD  |   | 51.14 | 56.25   | 1.5      | 1.5 | 2.0 | 2.0 | 16.70 | 14.48   | 1.40 | 1.27 | 0.10      | 0.00             | 0.00             |
| CONCRETE SPECIALIST        | All | BLD  |   | 51.81 | 58.21   | 1.5      | 1.5 | 2.0 | 2.0 | 12.95 | 27.56   | 0.00 | 1.57 | 0.00      | 4.88             | 9.75             |
| CONCRETE SPECIALIST WELDER | All | BLD  |   | 54.40 | 58.21   | 1.5      | 1.5 | 2.0 | 2.0 | 12.95 | 27.56   | 0.00 | 1.57 | 0.00      | 4.88             | 9.75             |
| ELECTRIC PWR EQMT OP       | All | ALL  |   | 64.58 | 70.87   | 1.5      | 1.5 | 2.0 | 2.0 | 12.99 | 22.45   | 0.00 | 3.66 | 0.00      | 0.00             | 0.00             |
| ELECTRIC PWR GRNDMAN       | All | ALL  |   | 50.37 | 70.87   | 1.5      | 1.5 | 2.0 | 2.0 | 10.13 | 17.51   | 0.00 | 2.85 | 0.00      | 0.00             | 0.00             |
| ELECTRIC PWR LINEMAN       | All | ALL  |   | 64.58 | 70.87   | 1.5      | 1.5 | 2.0 | 2.0 | 12.99 | 22.45   | 0.00 | 3.66 | 0.00      | 0.00             | 0.00             |
| ELECTRICIAN                | All | ALL  |   | 57.75 | 63.53   | 1.5      | 1.5 | 2.0 | 2.0 | 19.34 | 21.13   | 1.60 | 1.87 | 0.30      | 0.00             | 0.00             |
| ELEVATOR CONSTRUCTOR       | All | BLD  |   | 70.68 | 79.52   | 2.0      | 2.0 | 2.0 | 2.0 | 16.28 | 21.36   | 5.65 | 0.80 |           | 0.00             | 0.00             |
| FENCE ERECTOR              | All | ALL  |   | 52.25 | 54.75   | 1.5      | 1.5 | 2.0 | 2.0 | 14.29 | 19.02   | 0.00 | 1.00 | 0.00      | 0.00             | 0.00             |
| GLAZIER                    | All | BLD  |   | 53.55 | 55.05   | 1.5      | 2.0 | 2.0 | 2.0 | 16.04 | 26.64   | 0.00 | 2.30 | 0.00      | 0.00             | 0.00             |
| HEAT/FROST INSULATOR       | All | BLD  |   | 56.02 | 59.38   | 1.5      | 1.5 | 2.0 | 2.0 | 16.44 | 19.88   | 0.00 | 0.92 |           | 4.99             | 9.97             |
| IRON WORKER                | All | ALL  |   | 62.46 | 65.96   | 2.0      | 2.0 | 2.0 | 2.0 | 19.05 | 27.04   | 0.00 | 0.49 | 0.00      | 0.00             | 0.00             |
| LABORER                    | All | ALL  |   | 51.40 | 52.15   | 1.5      | 1.5 | 2.0 | 2.0 | 18.32 | 17.71   | 0.00 | 0.91 | 0.00      | 0.00             | 0.00             |
| LATHER                     | All | ALL  |   | 56.71 | 58.71   | 1.5      | 1.5 | 2.0 | 2.0 | 13.64 | 27.26   | 2.61 | 1.04 |           | 0.00             | 0.00             |
| MACHINIST                  | All | BLD  |   | 60.39 | 64.39   | 1.5      | 1.5 | 2.0 | 2.0 | 11.43 | 9.95    | 1.85 | 1.47 | 0.00      | 0.00             | 0.00             |
| MARBLE FINISHER            | All | ALL  |   | 40.21 | 54.60   | 1.5      | 1.5 | 2.0 | 2.0 | 12.95 | 23.81   | 0.00 | 0.98 | 0.00      | 3.00             | 6.00             |
| MARBLE SETTER              | All | BLD  |   | 52.00 | 57.20   | 1.5      | 1.5 | 2.0 | 2.0 | 12.95 | 25.57   | 0.00 | 1.25 | 0.00      | 3.88             | 7.76             |
| MATERIAL TESTER I          | All | ALL  |   | 41.40 |         | 1.5      | 1.5 | 2.0 | 2.0 | 18.32 | 17.71   | 0.00 | 0.91 | 0.00      | 0.00             | 0.00             |

## Cook County Prevailing Wage Rates posted on 3/2/2026

|                        |     |     |   |       |       |     |     |     |     |       |       |      |      |      |      |      |
|------------------------|-----|-----|---|-------|-------|-----|-----|-----|-----|-------|-------|------|------|------|------|------|
| MATERIALS TESTER II    | All | ALL |   | 46.40 |       | 1.5 | 1.5 | 2.0 | 2.0 | 18.32 | 17.71 | 0.00 | 0.91 | 0.00 | 0.00 | 0.00 |
| MILLWRIGHT             | All | ALL |   | 56.71 | 58.71 | 1.5 | 1.5 | 2.0 | 2.0 | 13.64 | 27.26 | 2.61 | 1.04 |      | 0.00 | 0.00 |
| OPERATING ENGINEER     | All | BLD | 1 | 64.80 | 68.80 | 2.0 | 2.0 | 2.0 | 2.0 | 24.70 | 21.55 | 2.00 | 2.75 |      | 0.00 | 0.00 |
| OPERATING ENGINEER     | All | BLD | 2 | 63.50 | 68.80 | 2.0 | 2.0 | 2.0 | 2.0 | 24.70 | 21.55 | 2.00 | 2.75 | 0.00 | 0.00 | 0.00 |
| OPERATING ENGINEER     | All | BLD | 3 | 60.95 | 68.80 | 2.0 | 2.0 | 2.0 | 2.0 | 24.70 | 21.55 | 2.00 | 2.75 |      | 0.00 | 0.00 |
| OPERATING ENGINEER     | All | BLD | 4 | 59.20 | 68.80 | 2.0 | 2.0 | 2.0 | 2.0 | 24.70 | 21.55 | 2.00 | 2.75 |      | 0.00 | 0.00 |
| OPERATING ENGINEER     | All | BLD | 5 | 68.55 | 68.80 | 2.0 | 2.0 | 2.0 | 2.0 | 24.70 | 21.55 | 2.00 | 2.75 |      | 0.00 | 0.00 |
| OPERATING ENGINEER     | All | BLD | 6 | 65.80 | 68.80 | 2.0 | 2.0 | 2.0 | 2.0 | 24.70 | 21.55 | 2.00 | 2.75 |      | 0.00 | 0.00 |
| OPERATING ENGINEER     | All | BLD | 7 | 67.80 | 68.80 | 2.0 | 2.0 | 2.0 | 2.0 | 24.70 | 21.55 | 2.00 | 2.75 |      | 0.00 | 0.00 |
| OPERATING ENGINEER     | All | FLT | 1 | 73.95 | 73.95 | 1.5 | 1.5 | 2.0 | 2.0 | 24.70 | 21.55 | 2.00 | 2.75 |      | 0.00 | 0.00 |
| OPERATING ENGINEER     | All | FLT | 2 | 72.45 | 73.95 | 1.5 | 1.5 | 2.0 | 2.0 | 24.70 | 21.55 | 2.00 | 2.75 |      | 0.00 | 0.00 |
| OPERATING ENGINEER     | All | FLT | 3 | 67.95 | 73.95 | 1.5 | 1.5 | 2.0 | 2.0 | 24.70 | 21.55 | 2.00 | 2.75 |      | 0.00 | 0.00 |
| OPERATING ENGINEER     | All | FLT | 4 | 63.45 | 73.95 | 1.5 | 1.5 | 2.0 | 2.0 | 24.70 | 21.55 | 2.00 | 2.75 |      | 0.00 | 0.00 |
| OPERATING ENGINEER     | All | FLT | 5 | 75.45 | 73.95 | 1.5 | 1.5 | 2.0 | 2.0 | 24.70 | 21.55 | 2.00 | 2.75 |      | 0.00 | 0.00 |
| OPERATING ENGINEER     | All | FLT | 6 | 63.45 | 73.95 | 1.5 | 1.5 | 2.0 | 2.0 | 24.70 | 21.55 | 2.00 | 2.75 |      | 0.00 | 0.00 |
| OPERATING ENGINEER     | All | HWY | 1 | 63.00 | 67.00 | 1.5 | 1.5 | 2.0 | 2.0 | 24.70 | 21.55 | 2.00 | 2.75 |      | 0.00 | 0.00 |
| OPERATING ENGINEER     | All | HWY | 2 | 62.45 | 67.00 | 1.5 | 1.5 | 2.0 | 2.0 | 24.70 | 21.55 | 2.00 | 2.75 |      | 0.00 | 0.00 |
| OPERATING ENGINEER     | All | HWY | 3 | 60.40 | 67.00 | 1.5 | 1.5 | 2.0 | 2.0 | 24.70 | 21.55 | 2.00 | 2.75 |      | 0.00 | 0.00 |
| OPERATING ENGINEER     | All | HWY | 4 | 59.00 | 67.00 | 1.5 | 1.5 | 2.0 | 2.0 | 24.70 | 21.55 | 2.00 | 2.75 |      | 0.00 | 0.00 |
| OPERATING ENGINEER     | All | HWY | 5 | 57.80 | 67.00 | 1.5 | 1.5 | 2.0 | 2.0 | 24.70 | 21.55 | 2.00 | 2.75 |      | 0.00 | 0.00 |
| OPERATING ENGINEER     | All | HWY | 6 | 66.00 | 67.00 | 1.5 | 1.5 | 2.0 | 2.0 | 24.70 | 21.55 | 2.00 | 2.75 |      | 0.00 | 0.00 |
| OPERATING ENGINEER     | All | HWY | 7 | 64.00 | 67.00 | 1.5 | 1.5 | 2.0 | 2.0 | 24.70 | 21.55 | 2.00 | 2.75 |      | 0.00 | 0.00 |
| ORNAMENTAL IRON WORKER | All | ALL |   | 59.26 | 62.76 | 2.0 | 2.0 | 2.0 | 2.0 | 14.86 | 27.70 | 0.00 | 2.25 | 0.00 | 0.00 | 0.00 |
| PAINTER                | All | ALL |   | 54.30 | 61.09 | 1.5 | 1.5 | 1.5 | 2.0 | 16.26 | 17.59 | 0.00 | 1.86 | 0.00 | 0.00 | 0.00 |
| PAINTER - SIGNS        | All | BLD |   | 48.16 | 54.11 | 1.5 | 1.5 | 2.0 | 2.0 | 8.20  | 16.81 | 0.00 | 0.00 | 0.00 | 0.00 | 0.00 |
| PILEDRIIVER            | All | ALL |   | 56.71 | 58.71 | 1.5 | 1.5 | 2.0 | 2.0 | 13.64 | 27.26 | 2.61 | 1.04 |      | 0.00 | 0.00 |
| PIPEFITTER             | All | BLD |   | 58.50 | 61.50 | 1.5 | 1.5 | 2.0 | 2.0 | 15.15 | 22.85 | 0.00 | 3.12 | 0.00 | 0.00 | 0.00 |
| PLASTERER              | All | BLD |   | 51.10 | 54.17 | 1.5 | 1.5 | 2.0 | 2.0 | 18.43 | 22.10 | 0.00 | 1.25 | 0.00 | 0.00 | 0.00 |
| PLUMBER                | All | BLD |   | 60.50 | 64.15 | 1.5 | 1.5 | 2.0 | 2.0 | 19.10 | 17.94 | 0.00 | 1.98 |      | 0.00 | 0.00 |

## Cook County Prevailing Wage Rates posted on 3/2/2026

|                          |     |     |   |       |       |     |     |     |     |       |       |      |      |      |      |      |
|--------------------------|-----|-----|---|-------|-------|-----|-----|-----|-----|-------|-------|------|------|------|------|------|
| ROOFER                   | All | BLD |   | 52.00 | 57.00 | 1.5 | 1.5 | 2.0 | 2.0 | 12.80 | 18.19 | 0.00 | 1.14 | 0.00 | 0.00 | 0.00 |
| SHEETMETAL WORKER        | All | BLD |   | 54.58 | 58.95 | 1.5 | 1.5 | 2.0 | 2.0 | 15.88 | 28.92 | 0.00 | 1.20 | 0.00 | 0.00 | 0.00 |
| SIGN HANGER              | All | BLD |   | 37.62 | 40.63 | 1.5 | 1.5 | 2.0 | 2.0 | 7.85  | 4.90  | 0.00 | 0.00 | 0.00 | 0.00 | 0.00 |
| SPRINKLER FITTER         | All | BLD |   | 63.20 | 65.95 | 1.5 | 1.5 | 2.0 | 2.0 | 15.45 | 19.95 | 0.00 | 1.15 | 0.00 | 0.00 | 0.00 |
| STEEL ERECTOR            | All | ALL |   | 62.46 | 65.96 | 2.0 | 2.0 | 2.0 | 2.0 | 19.05 | 27.04 | 0.00 | 0.49 | 0.00 | 0.00 | 0.00 |
| STONE MASON              | All | BLD |   | 53.06 | 58.37 | 1.5 | 1.5 | 2.0 | 2.0 | 12.95 | 26.26 | 0.00 | 1.57 | 0.00 | 4.23 | 8.45 |
| SURVEY WORKER            | All | BLD |   | 58.45 | 59.45 | 1.5 | 1.5 | 2.0 | 2.0 | 19.10 | 14.40 | 0.00 | 1.59 |      | 0.00 | 0.00 |
| SURVEY WORKER            | All | HWY |   | 58.45 | 59.45 | 1.5 | 1.5 | 2.0 | 2.0 | 19.10 | 14.40 | 0.00 | 1.59 |      | 0.00 | 0.00 |
| TERRAZZO FINISHER        | All | BLD |   | 51.44 | 51.44 | 1.5 | 1.5 | 2.0 | 2.0 | 13.25 | 18.87 | 0.00 | 1.41 | 0.00 | 4.45 | 8.89 |
| TERRAZZO MECHANIC        | All | BLD |   | 55.35 | 58.85 | 1.5 | 1.5 | 2.0 | 2.0 | 13.25 | 20.26 | 0.00 | 1.46 | 0.00 | 4.70 | 9.39 |
| TRAFFIC SAFETY WORKER I  | All | HWY |   | 43.40 | 45.40 | 1.5 | 1.5 | 2.0 | 2.0 | 10.08 | 10.08 | 0.00 | 1.05 | 0.00 | 0.00 | 0.00 |
| TRAFFIC SAFETY WORKER II | ALL | HWY |   | 44.40 | 46.40 | 1.5 | 1.5 | 2.0 | 2.0 | 10.08 | 10.08 | 0.00 | 1.05 | 0.00 | 0.00 | 0.00 |
| TRUCK DRIVER             | E   | ALL | 1 | 45.55 | 46.20 | 1.5 | 1.5 | 2.0 | 2.0 | 13.35 | 16.09 | 0.00 | 0.30 | 0.00 | 0.00 | 0.00 |
| TRUCK DRIVER             | E   | ALL | 2 | 45.80 | 46.20 | 1.5 | 1.5 | 2.0 | 2.0 | 13.35 | 16.09 | 0.00 | 0.30 | 0.00 | 0.00 | 0.00 |
| TRUCK DRIVER             | E   | ALL | 3 | 46.00 | 46.20 | 1.5 | 1.5 | 2.0 | 2.0 | 13.35 | 16.09 | 0.00 | 0.30 | 0.00 | 0.00 | 0.00 |
| TRUCK DRIVER             | E   | ALL | 4 | 46.20 | 46.20 | 1.5 | 1.5 | 2.0 | 2.0 | 13.35 | 16.09 | 0.00 | 0.30 | 0.00 | 0.00 | 0.00 |
| TRUCK DRIVER             | W   | ALL | 1 | 44.83 | 45.38 | 1.5 | 1.5 | 2.0 | 2.0 | 12.20 | 16.61 | 0.00 | 0.30 | 0.00 | 0.00 | 0.00 |
| TRUCK DRIVER             | W   | ALL | 2 | 44.98 | 45.38 | 1.5 | 1.5 | 2.0 | 2.0 | 12.20 | 16.61 | 0.00 | 0.30 | 0.00 | 0.00 | 0.00 |
| TRUCK DRIVER             | W   | ALL | 3 | 45.18 | 45.38 | 1.5 | 1.5 | 2.0 | 2.0 | 12.20 | 16.61 | 0.00 | 0.30 | 0.00 | 0.00 | 0.00 |
| TRUCK DRIVER             | W   | ALL | 4 | 45.38 | 45.38 | 1.5 | 1.5 | 2.0 | 2.0 | 12.20 | 16.61 | 0.00 | 0.30 | 0.00 | 0.00 | 0.00 |
| TUCK POINTER             | All | BLD |   | 52.53 | 53.53 | 1.5 | 1.5 | 2.0 | 2.0 | 11.05 | 23.16 | 0.00 | 1.46 | 0.00 | 0.00 | 0.00 |

### Legend

**Rg** Region

**Type** Trade Type - All,Highway,Building,Floating,Oil & Chip,Rivers

**C** Class

**Base** Base Wage Rate

**OT M-F** Unless otherwise noted, OT pay is required for any hour greater than 8 worked each day, Mon through Fri. The number listed is the multiple of the base wage.

**OT Sa** Overtime pay required for every hour worked on Saturdays

**OT Su** Overtime pay required for every hour worked on Sundays

**OT Hol** Overtime pay required for every hour worked on Holidays

## Cook County Prevailing Wage Rates posted on 3/2/2026

**H/W** Health/Welfare benefit

**Vac** Vacation

**Trng** Training

**Other Ins** Employer hourly cost for any other type(s) of insurance provided for benefit of worker.

Explanations COOK COUNTY

The following list is considered as those days for which holiday rates of wages for work performed apply: New Years Day, Memorial Day, Fourth of July, Labor Day, Thanksgiving Day, Christmas Day and Veterans Day in some classifications/counties. Generally, any of these holidays which fall on a Sunday is celebrated on the following Monday. This then makes work performed on that Monday payable at the appropriate overtime rate for holiday pay. Common practice in a given local may alter certain days of celebration. If in doubt, please check with IDOL.

TRUCK DRIVERS (WEST) - That part of the county West of Barrington Road.

EXPLANATION OF CLASSES

ASBESTOS - GENERAL - removal of asbestos material/mold and hazardous materials from any place in a building, including mechanical systems where those mechanical systems are to be removed. This includes the removal of asbestos materials/mold and hazardous materials from ductwork or pipes in a building when the building is to be demolished at the time or at some close future date. ASBESTOS - MECHANICAL - removal of asbestos material from mechanical systems, such as pipes, ducts, and boilers, where the mechanical systems are to remain.

CERAMIC TILE FINISHER

The grouting, cleaning, and polishing of all classes of tile, whether for interior or exterior purposes, all burned, glazed or unglazed products; all composition materials, granite tiles, warning detectable tiles, cement tiles, epoxy composite materials, pavers, glass, mosaics, fiberglass, and all substitute materials, for tile made in tile-like units; all mixtures in tile like form of cement, metals, and other materials that are for and intended for use as a finished floor surface, stair treads, promenade roofs, walks, walls, ceilings, swimming pools, and all other places where tile is to form a finished interior or exterior. The mixing of all setting mortars including but not limited to thin-set mortars, epoxies, wall mud, and any other sand and cement mixtures or adhesives when used in the preparation, installation, repair, or maintenance of tile and/or similar materials. The handling and unloading of all sand, cement, lime, tile, fixtures, equipment, adhesives, or any other materials to be used in the preparation, installation, repair, or maintenance of tile and/or similar materials. Ceramic Tile Finishers shall fill all joints and voids regardless of method on all tile work, particularly and especially after installation of said tile work. Application of any and all protective coverings to all types of tile installations including, but not be limited to, all soap compounds, paper products, tapes, and all polyethylene coverings, plywood, masonite, cardboard, and any new type of products that may be used to protect tile installations, Blastrac equipment, and all floor scarifying equipment used in preparing floors to receive tile. The clean up and removal of all waste and materials. All demolition of existing tile floors and walls to be re-tiled.

COMMUNICATIONS ELECTRICIAN

## **Cook County Prevailing Wage Rates posted on 3/2/2026**

Installation, operation, inspection, maintenance, repair and service of radio, television, recording, voice sound vision production and reproduction, telephone and telephone interconnect, facsimile, data apparatus, coaxial, fibre optic and wireless equipment, appliances and systems used for the transmission and reception of signals of any nature, business, domestic, commercial, education, entertainment, and residential purposes, including but not limited to, communication and telephone, electronic and sound equipment, fibre optic and data communication systems, and the performance of any task directly related to such installation or service whether at new or existing sites, such tasks to include the placing of wire and cable and electrical power conduit or other raceway work within the equipment room and pulling wire and/or cable through conduit and the installation of any incidental conduit, such that the employees covered hereby can complete any job in full.

### **MARBLE FINISHER**

Loading and unloading trucks, distribution of all materials (all stone, sand, etc.), stocking of floors with material, performing all rigging for heavy work, the handling of all material that may be needed for the installation of such materials, building of scaffolding, polishing if needed, patching, waxing of material if damaged, pointing up, caulking, grouting and cleaning of marble, holding water on diamond or Carborundum blade or saw for setters cutting, use of tub saw or any other saw needed for preparation of material, drilling of holes for wires that anchor material set by setters, mixing up of molding plaster for installation of material, mixing up thin set for the installation of material, mixing up of sand to cement for the installation of material and such other work as may be required in helping a Marble Setter in the handling of all material in the erection or installation of interior marble, slate, travertine, art marble, serpentine, alberene stone, blue stone, granite and other stones (meaning as to stone any foreign or domestic materials as are specified and used in building interiors and exteriors and customarily known as stone in the trade), carrara, sanionyx, vitrolite and similar opaque glass and the laying of all marble tile, terrazzo tile, slate tile and precast tile, steps, risers treads, base, or any other materials that may be used as substitutes for any of the aforementioned materials and which are used on interior and exterior which are installed in a similar manner.

MATERIAL TESTER I: Hand coring and drilling for testing of materials; field inspection of uncured concrete and asphalt.

MATERIAL TESTER II: Field inspection of welds, structural steel, fireproofing, masonry, soil, facade, reinforcing steel, formwork, cured concrete, and concrete and asphalt batch plants; adjusting proportions of bituminous mixtures.

### **OPERATING ENGINEER - BUILDING**

Class 1. Asphalt Plant; Asphalt Spreader; Autograde; Backhoes with Caisson Attachment; Batch Plant; Benoto (requires Two Engineers); Boiler and Throttle Valve; Caisson Rigs; Central Redi-Mix Plant; Combination Back Hoe Front End-loader Machine; Compressor and Throttle Valve; Concrete Breaker (Truck Mounted); Concrete Conveyor; Concrete Conveyor (Truck Mounted); Concrete Paver Over 27E cu. ft; Concrete Paver 27E cu. ft. and Under: Concrete Placer; Concrete Placing Boom; Concrete Pump (Truck Mounted); Concrete Tower; Cranes, All; Cranes, Hammerhead; Cranes, (GCI and similar Type); Creter Crane; Spider Crane; Crusher, Stone, etc.; Derricks, All; Derricks, Traveling; Formless Curb and Gutter Machine; Grader, Elevating; Grouting Machines; Heavy Duty Self-Propelled Transporter or Prime Mover; Highlift Shovels or Front Endloader 2-1/4 yd. and over; Hoists, Elevators, outside type rack and pinion and similar machines; Hoists, One, Two and Three Drum; Hoists, Two Tugger One Floor; Hydraulic Backhoes; Hydraulic Boom Trucks; Hydro Vac (and similar equipment); Locomotives, All; Motor Patrol; Lubrication Technician; Manipulators; Pile Drivers and Skid Rig; Post Hole Digger; Pre-Stress Machine; Pump Cretes Dual Ram; Pump Cretes: Squeeze Cretes-Screw Type Pumps; Gypsum Bulker and Pump; Raised and Blind Hole Drill; Roto Mill Grinder; Scoops - Tractor Drawn; Slip-

## **Cook County Prevailing Wage Rates posted on 3/2/2026**

Form Paver; Straddle Buggies; Operation of Tie Back Machine; Tournapull; Tractor with Boom and Side Boom; Trenching Machines.

Class 2. Boilers; Broom, All Power Propelled; Bulldozers; Concrete Mixer (Two Bag and Over); Conveyor, Portable; Forklift Trucks; Highlift Shovels or Front Endloaders under 2-1/4 yd.; Hoists, Automatic; Hoists, Inside Elevators; Hoists, Sewer Dragging Machine; Hoists, Tugger Single Drum; Laser Screed; Rock Drill (Self-Propelled); Rock Drill (Truck Mounted); Rollers, All; Steam Generators; Tractors, All; Tractor Drawn Vibratory Roller; Winch Trucks with "A" Frame.

Class 3. Air Compressor; Combination Small Equipment Operator; Generators; Heaters, Mechanical; Hoists, Inside Elevators (remodeling or renovation work); Hydraulic Power Units (Pile Driving, Extracting, and Drilling); Pumps, over 3" (1 to 3 not to exceed a total of 300 ft.); Low Boys; Pumps, Well Points; Welding Machines (2 through 5); Winches, 4 Small Electric Drill Winches.

Class 4. Bobcats and/or other Skid Steer Loaders; Oilers; and Brick Forklift.

Class 5. Assistant Craft Foreman.

Class 6. Gradall.

Class 7. Mechanics; Welders.

### **OPERATING ENGINEERS - HIGHWAY CONSTRUCTION**

Class 1. Asphalt Plant; Asphalt Heater and Planer Combination; Asphalt Heater Scarfire; Asphalt Spreader; Autograder/GOMACO or other similar type machines; ABG Paver; Backhoes with Caisson Attachment; Ballast Regulator; Belt Loader; Caisson Rigs; Car Dumper; Central Redi-Mix Plant; Combination Backhoe Front Endloader Machine, (1 cu. yd. Backhoe Bucket or over or with attachments); Concrete Breaker (Truck Mounted); Concrete Conveyor; Concrete Paver over 27E cu. ft.; Concrete Placer; Concrete Tube Float; Cranes, all attachments; Cranes, Tower Cranes of all types: Creter Crane; Spider Crane; Crusher, Stone, etc.; Derricks, All; Derrick Boats; Derricks, Traveling; Dredges; Elevators, Outside type Rack & Pinion and Similar Machines; Formless Curb and Gutter Machine; Grader, Elevating; Grader, Motor Grader, Motor Patrol, Auto Patrol, Form Grader, Pull Grader, Subgrader; Guard Rail Post Driver Truck Mounted; Hoists, One, Two and Three Drum; Heavy Duty Self-Propelled Transporter or Prime Mover; Hydraulic Backhoes; Backhoes with shear attachments up to 40' of boom reach; Lubrication Technician; Manipulators; Mucking Machine; Pile Drivers and Skid Rig; Pre-Stress Machine; Pump Cretes Dual Ram; Rock Drill - Crawler or Skid Rig; Rock Drill - Truck Mounted; Rock/Track Tamper; Roto Mill Grinder; Slip-Form Paver; Snow Melters; Soil Test Drill Rig (Truck Mounted); Straddle Buggies; Hydraulic Telescoping Form (Tunnel); Operation of Tieback Machine; Tractor Drawn Belt Loader; Tractor Drawn Belt Loader (with attached pusher - two engineers); Tractor with Boom; Tractaire with Attachments; Traffic Barrier Transfer Machine; Trenching; Truck Mounted Concrete Pump with Boom; Raised or Blind Hole Drills (Tunnel Shaft); Underground Boring and/or Mining Machines 5 ft. in diameter and over tunnel, etc; Underground Boring and/or Mining Machines under 5 ft. in diameter; Wheel Excavator; Widener (APSCO).

Class 2. Batch Plant; Bituminous Mixer; Boiler and Throttle Valve; Bulldozers; Car Loader Trailing Conveyors; Combination Backhoe Front Endloader Machine (Less than 1 cu. yd. Backhoe Bucket or over or with attachments); Compressor and Throttle Valve; Compressor, Common Receiver (3); Concrete Breaker or Hydro Hammer; Concrete Grinding Machine; Concrete Mixer or Paver 7S

## **Cook County Prevailing Wage Rates posted on 3/2/2026**

Series to and including 27 cu. ft.; Concrete Spreader; Concrete Curing Machine, Burlap Machine, Belting Machine and Sealing Machine; Concrete Wheel Saw; Conveyor Muck Cars (Haglund or Similar Type); Drills, All; Finishing Machine - Concrete; Highlift Shovels or Front Endloader; Hoist - Sewer Dragging Machine; Hydraulic Boom Trucks (All Attachments); Hydro-Blaster; Hydro Excavating (excluding hose work); Laser Screed; All Locomotives, Dinky; Off-Road Hauling Units (including articulating) Non Self-Loading Ejection Dump; Pump Cretes: Squeeze Cretes - Screw Type Pumps, Gypsum Bulker and Pump; Roller, Asphalt; Rotary Snow Plows; Rototiller, Seaman, etc., self-propelled; Self-Propelled Compactor; Spreader - Chip - Stone, etc.; Scraper - Single/Twin Engine/Push and Pull; Scraper - Prime Mover in Tandem (Regardless of Size); Tractors pulling attachments, Sheeps Foot, Disc, Compactor, etc.; Tug Boats.

Class 3. Boilers; Brooms, All Power Propelled; Cement Supply Tender; Compressor, Common Receiver (2); Concrete Mixer (Two Bag and Over); Conveyor, Portable; Farm-Type Tractors Used for Mowing, Seeding, etc.; Forklift Trucks; Grouting Machine; Hoists, Automatic; Hoists, All Elevators; Hoists, Tugger Single Drum; Jeep Diggers; Low Boys; Pipe Jacking Machines; Post-Hole Digger; Power Saw, Concrete Power Driven; Pug Mills; Rollers, other than Asphalt; Seed and Straw Blower; Steam Generators; Stump Machine; Winch Trucks with "A" Frame; Work Boats; Tamper-Form-Motor Driven.

Class 4. Air Compressor; Combination - Small Equipment Operator; Directional Boring Machine; Generators; Heaters, Mechanical; Hydraulic Power Unit (Pile Driving, Extracting, or Drilling); Light Plants, All (1 through 5); Pumps, over 3" (1 to 3 not to exceed a total of 300 ft.); Pumps, Well Points; Vacuum Trucks (excluding hose work); Welding Machines (2 through 5); Winches, 4 Small Electric Drill Winches.

Class 5. SkidSteer Loader (all); Brick Forklifts; Oilers.

Class 6. Field Mechanics and Field Welders

Class 7. Dowell Machine with Air Compressor; Gradall and machines of like nature.

### **OPERATING ENGINEER - FLOATING**

Class 1. Craft Foreman; Master Mechanic; Diver/Wet Tender; Engineer; Engineer (Hydraulic Dredge).

Class 2. Crane/Backhoe Operator; Boat Operator with towing endorsement; Mechanic/Welder; Assistant Engineer (Hydraulic Dredge); Leverman (Hydraulic Dredge); Diver Tender.

Class 3. Deck Equipment Operator, Machineryman, Maintenance of Crane (over 50 ton capacity) or Backhoe (115,000 lbs. or more); Tug/Launch Operator; Loader/Dozer and like equipment on Barge, Breakwater Wall, Slip/Dock, or Scow, Deck Machinery, etc.

Class 4. Deck Equipment Operator, Machineryman/Fireman (4 Equipment Units or More); Off Road Trucks; Deck Hand, Tug Engineer, Crane Maintenance (50 Ton Capacity and Under) or Backhoe Weighing (115,000 pounds or less); Assistant Tug Operator.

Class 5. Friction or Lattice Boom Cranes.

## **Cook County Prevailing Wage Rates posted on 3/2/2026**

Class 6. ROV Pilot, ROV Tender

### **SURVEY WORKER**

Operates survey equipment (such as levels, transits, data collectors, GPS and robotic total stations) for the purpose of performing construction layout and/or grade checking.

### **SURVEY FOREMAN**

Operates survey equipment (such as levels, transits, data collectors, GPS and robotic total stations) for the purpose of performing construction layout and/or grade checking; oversees survey crew operations; and/or coordinates work of survey crews.

### **TERRAZZO FINISHER**

The handling of sand, cement, marble chips, and all other materials that may be used by the Mosaic Terrazzo Mechanic, and the mixing, grinding, grouting, cleaning and sealing of all Marble, Mosaic, and Terrazzo work, floors, base, stairs, and wainscoting by hand or machine, and in addition, assisting and aiding Marble, Masonic, and Terrazzo Mechanics.

### **TRAFFIC SAFETY Worker I**

Traffic Safety Worker I - work associated with the delivery, installation, pick-up and servicing of safety devices during periods of roadway construction, including such work as set-up and maintenance of barricades, barrier wall reflectors, drums, cones, delineators, signs, crash attenuators, glare screen and other such items, and the layout and application or removal of conflicting and/or temporary roadway markings utilized to control traffic in construction zones, as well as flagging for these operations.

### **TRAFFIC SAFETY WORKER II**

Work associated with the installation and removal of permanent pavement markings and/or pavement markers including both installations performed by hand and installations performed by truck.

### **TRUCK DRIVER - BUILDING, HEAVY AND HIGHWAY CONSTRUCTION - EAST & WEST**

Class 1. Two or three Axle Trucks. A-frame Truck when used for transportation purposes; Air Compressors and Welding Machines, including those pulled by cars, pick-up trucks and tractors; Ambulances; Batch Gate Lockers; Batch Hopperman; Car and Truck Washers; Carry-alls; Fork Lifts and Hoisters; Helpers; Mechanics Helpers and Greasers; Oil Distributors 2-man operation; Pavement Breakers; Pole Trailer, up to 40 feet; Power Mower Tractors; Self-propelled Chip Spreader; Skipman; Slurry Trucks, 2-man operation; Slurry Truck Conveyor Operation, 2 or 3 man; Teamsters; Unskilled Dumpman; and Truck Drivers hauling warning lights, barricades, and portable toilets on the job site.

Class 2. Four axle trucks; Dump Crets and Adgetors under 7 yards; Dumpsters, Track Trucks, Euclids, Hug Bottom Dump Turnpulls or Turntrailers when pulling other than self-loading equipment or similar equipment under 16 cubic yards; Mixer Trucks under 7 yards; Ready-mix Plant Hopper Operator, and Winch Trucks, 2 Axles.

Class 3. Five axle trucks; Dump Crets and Adgetors 7 yards and over; Dumpsters, Track Trucks, Euclids, Hug Bottom Dump

## **Cook County Prevailing Wage Rates posted on 3/2/2026**

Turntrailers or turnpulls when pulling other than self-loading equipment or similar equipment over 16 cubic yards; Explosives and/or Fission Material Trucks; Mixer Trucks 7 yards or over; Mobile Cranes while in transit; Oil Distributors, 1-man operation; Pole Trailer, over 40 feet; Pole and Expandable Trailers hauling material over 50 feet long; Slurry trucks, 1-man operation; Winch trucks, 3 axles or more; Mechanic--Truck Welder and Truck Painter.

Class 4. Six axle trucks; Dual-purpose vehicles, such as mounted crane trucks with hoist and accessories; Foreman; Master Mechanic; Self-loading equipment like P.B. and trucks with scoops on the front.

### Other Classifications of Work:

For definitions of classifications not otherwise set out, the Department generally has on file such definitions which are available. If a task to be performed is not subject to one of the classifications of pay set out, the Department will upon being contacted state which neighboring county has such a classification and provide such rate, such rate being deemed to exist by reference in this document. If no neighboring county rate applies to the task, the Department shall undertake a special determination, such special determination being then deemed to have existed under this determination. If a project requires these, or any classification not listed, please contact IDOL at 217-782-1710 for wage rates or clarifications.

### LANDSCAPING

Landscaping work falls under the existing classifications for laborer, operating engineer and truck driver. The work performed by landscape plantsman and landscape laborer is covered by the existing classification of laborer. The work performed by landscape operators (regardless of equipment used or its size) is covered by the classifications of operating engineer. The work performed by landscape truck drivers (regardless of size of truck driven) is covered by the classifications of truck driver.

### MATERIAL TESTER & MATERIAL TESTER/INSPECTOR I AND II

Notwithstanding the difference in the classification title, the classification entitled "Material Tester I" involves the same job duties as the classification entitled "Material Tester/Inspector I". Likewise, the classification entitled "Material Tester II" involves the same job duties as the classification entitled "Material Tester/Inspector II".

**Cook County Prevailing Wage Rates posted on 3/2/2026**

**City of Evanston** has partnered with **Euna OpenBids** – an online network connecting local governments with suppliers across the nation. Euna OpenBids is open and accessible to all businesses. Euna OpenBids gives you instant access to RFPs, bids, quotes, and other opportunities with City of Evanston.

By registering for a complimentary account with Euna OpenBids, you get Instant Access to bids for City of Evanston. Your free Euna OpenBids account provides:

- **Instant** access to all bid and quotes for City of Evanston
- **Automatic** notifications from City of Evanston right to your inbox
- The ability to **quickly view** the contractual terms and scope of work
- All the **forms and documents** you need in one place.

**It's Easy! Get started in 4 easy steps.**

## REGISTER

Go to  
[demandstar.com/registration](https://demandstar.com/registration)

### Get started for free!

Company Name

Email Address

This will be your username for logging in to OpenBids

Create your OpenBids account

Sign In

By creating an account, you agree to OpenBids Terms of Use and Privacy Policy.

STEP 1

## CHOOSE YOUR FREE AGENCY

Type "City of Evanston" in the Search Box, select the agency, then click "Next".

### 1 of 4: Choose your free agency

A great way to find out about new opportunities on OpenBids is to subscribe to a government agency. To get started, please choose your first (free!) agency. You'll have a chance to sign up for more in just a moment.

Search by Agency Name

State

County

[Reset Search](#)

York County Purchasing

STEP 2

## CHOOSE COMMODITY CODES

Get notifications – ones that are relevant to your business by describing what you offer via “commodity codes”

### 2 of 4: Refine Bid Notifications

#### What are commodity codes?

OpenBids commodity codes are how we categorize goods and services for government procurement. When you choose commodity codes, OpenBids uses them to match what your company provides to what governments in your subscription need, helping you find the best bids and quotes to bid on.

Take control of your bid notification experience and maximize your chances of finding opportunities that are tailored to your needs. Add your key tags here and let us assist you in uncovering the most relevant and valuable bid opportunities in your industry.

Example: Infrastructure, Automobiles, Dairy, Agriculture

Search

Go Back

[Skip Commodity Codes and Tags](#)

Continue

STEP 3

## CHOOSE MORE NOTIFICATIONS

Click “Continue without Adding Subscriptions” to proceed to City of Evanston specifically. Or, if you’d like to get notifications when other governments near you post a relevant solicitation, you can select any combination of our county, state or national plans on this page.

### 3 of 4: Choose Subscriptions

Now that you've chosen **Rock County** as your free agency, add more counties to grow your network of potential clients.

County subscriptions start at \$25 per year.

#### Please select a state to begin

State

Wisconsin

#### Choose your counties in Wisconsin

There are currently 51 Wisconsin counties with agencies publishing bids on OpenBids. Please choose which counties you'd like to subscribed to. You may also subscribe to all counties in Wisconsin and save!

+ Subscribe to Wisconsin for \$450 / year

Search for Counties

Search for Counties

#### Rock County Subscription

Rock County is in Rock County. Subscribe and get notifications from 4 agencies.

[Subscribe to Rock County for \\$35/year](#)

#### Wisconsin Subscription

Rock County is in Wisconsin. Subscribe and get notifications from 146 agencies.

[Subscribe to Wisconsin for \\$450/year](#)

#### National Subscription

Choose a national subscription and get notifications from 2884 agencies.

STEP 4

## COMPLETE YOUR PROFILE

Enter your contact and company information and Click “Finish Registration”. You’ll receive an email to set up your password.

You’re done!

### 4 of 4: Complete your profile

We've saved your selections. Now that you've set up your subscriptions on OpenBids, tell us a little bit more about yourself.

#### Your contact information

First Name

Last Name

Phone Number

#### Your company Information

Company Phone Number